



MILLFORM
AUSTRALIA

Where strength matters



EXTREME
PURLIN™

MILLFORM EXTREME PURLIN GUIDE & CAPACITY TABLES

C & Z EXTREME PURLINS



**MILLFORM
AUSTRALIA**

Where strength matters



With the strength of steel, Millform is dedicated to building a better Australia. We provide quality products, ensure efficient delivery standards, and offer proven solutions for commercial, construction, industrial, and government clients.

You can find other Millform items on our website.

www.millform.com.au

EXTREME
PURLIN™

TABLE OF CONTENT

PAGE

GENERAL INFORMATION

3

• Application	3
• Construction Material	3
• Installation Process	3
• Sheet Length & Expansion Joint Sizing	3
• Welding	3
• Safe Work Practice	3
• Material Protection & Compatibility	3
• On-site Storage	3

PRODUCT RANGE

4

USING THE MANUAL

9

DESIGN & SPECIFICATION

10

• Hole Punching	10
• Structural Lap Lengths	10
• Member Weight	12
• Deflection	12
• Cleat Connections	13
• Bolts	13
• Point Loads	13

HOW TO USE THE TABLES

14

SPAN TABLES & SECTION PROPERTIES

15

HOOKFASST BRIDGING SYSTEM

28

GENERAL INFORMATION



Application

At Millform, we supply purlins and girts to support roof and wall sheeting. Our products are used in a variety of industrial, commercial, construction, and civil applications.

Construction Materials

Our **Extreme Purlin™** purlins and girts are manufactured from high-quality galvanised steel. We use G450, G500, and G550 products with a minimum Z350 coating. All materials conform to AS 1397.

Installation Process

We have access to an expansive shipping network, with all materials delivered quickly and safely to avoid project delays. We can deliver to most addresses across Australia.

Sheeting and Expansion Joint Sizing

We adapt roof sheeting sizes based on thermal expansion, transportation, and handling requirements. Recommended roof sheeting lengths may vary between projects and state locations.

MAXIMUM ROOF SHEET LENGTH

ROOF COLOUR	THROUGH FIX	CONCEALED FIX
Light	25m	33m
Dark	17m	25 m

Where buildings are designed with roofing runs greater than the table above, expansion joints are necessary.

TYPICAL EXPANSION JOINT

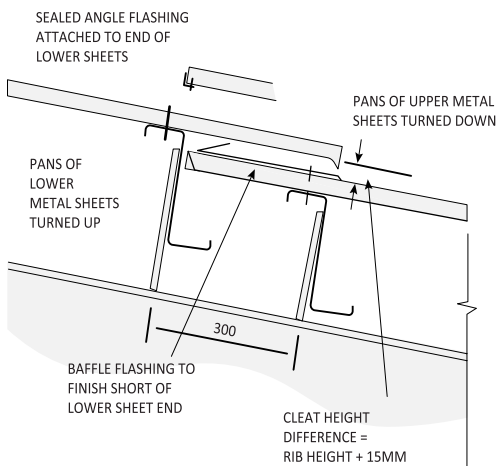

Welding Not Required

Welding is not recommended for purlins, girts, or bridging materials. Cold rolled steel is a high-tensile material, with welding likely to remove the galvanised coating and reduce the lifespan of the product.

Safe Work Practices

Millform strives for the highest levels of safe work practice both internally in our production process and externally in the delivery and handling of our products. Be aware that when material gets wet or moist it can lead to a hazardous situation. We strongly recommend not to walk on steel in these conditions and take extreme care when moving or lifting steel as it can slip off forklifts or cranes. Take time to perform a risk assessment and use the correct equipment.

Material Protection and Compatibility

Some building materials and environmental conditions function poorly with coated steel products. It's important to avoid run-off exposure or contact that results from aggressive atmospheric conditions, incompatible materials, excessive moisture, and treated materials. Incompatible metals include lead and copper, excessive moisture is likely with non-seasoned timber, and treated materials include CCA and tanalith.

When installed correctly in the right locations, standard Z350 galvanised coating will provide a long and maintenance-free life. Typical applications include enclosed buildings and open-sided rural applications in standard environments. While Z450 is available for extreme corrosive settings, this product is subject to extended lead times and minimum order amounts.

On-site Storage

Safe above-ground storage is critical for Z and C sections or bundles. If extended storage is needed, it's important to store materials with a small incline to avoid water from pooling. Materials and equipment should be protected with waterproof covers and never left exposed to the elements for a long period of time.

Where strength matters





PRODUCT RANGE & PROPERTIES

Extreme Purlin™ C & Z Sections and Other Shapes

C and Z sections are readily available, and other shapes are available subject to extended lead times and minimum order requirements. Purlins and girts are available in the following sizes:

C SECTIONS

EXTREME C



Z SECTIONS

EXTREME Z

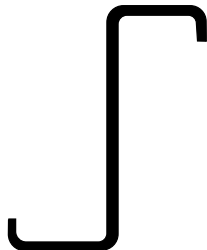

C – Section Extreme Purlin

C150 Purlin

PURLIN - EX_C150 X 58 X 1.20 BMT: **EX_C150_58_1.20G** (2.83kg/m)

PURLIN - EX_C150 X 58 X 1.50 BMT: **EX_C150_58_1.50G** (3.52kg/m)

PURLIN - EX_C150 X 58 X 1.90 BMT: **EX_C150_58_1.90G** (4.45kg/m)

PURLIN - EX_C150 X 58 X 2.40 BMT: **EX_C150_58_2.40G** (5.60kg/m)

Standard Pack: 50 Lengths

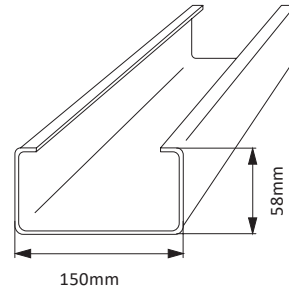

C200 Purlin

PURLIN - EX_C200 X 72 X 1.20 BMT: **EX_C200_72_1.20G** (3.59kg/m)

PURLIN - EX_C200 X 72 X 1.50 BMT: **EX_C200_72_1.50G** (4.47kg/m)

PURLIN - EX_C200 X 72 X 1.90 BMT: **EX_C200_72_1.90G** (5.65kg/m)

PURLIN - EX_C200 X 72 X 2.40 BMT: **EX_C200_72_2.40G** (7.12kg/m)

Standard Pack: 50 Lengths

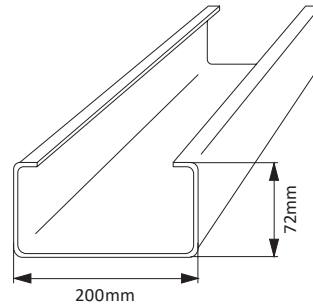

C250 Purlin

PURLIN - EX_C250 X 73 X 1.50 BMT: **EX_C250_73_1.50G** (5.07kg/m)

PURLIN - EX_C250 X 73 X 1.90 BMT: **EX_C250_73_1.90G** (6.41kg/m)

PURLIN - EX_C250 X 73 X 2.40 BMT: **EX_C250_73_2.40G** (8.07kg/m)

Standard Pack: 40 Lengths

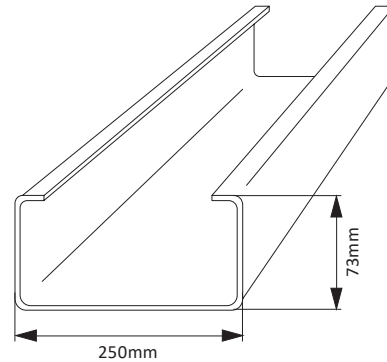

C300 Purlin

PURLIN - EX_C300 X 93 X 1.90 BMT: **EX_C300_93_1.90G** (7.91kg/m)

PURLIN - EX_C300 X 93 X 2.40 BMT: **EX_C300_93_2.40G** (9.97kg/m)

PURLIN - EX_C300 X 93 X 3.00 BMT: **EX_C300_93_3.00G** (12.51kg/m)

Standard Pack: 20 Lengths

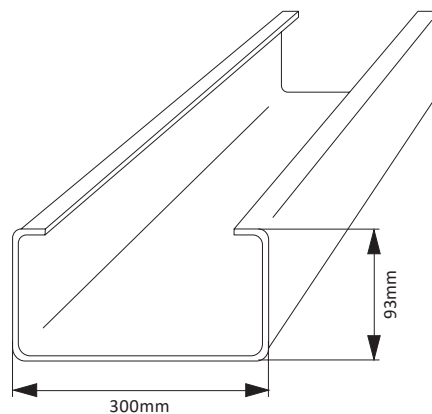

Where strength matters



NOTE: C & Z Purlins are only manufactured down to 2m lengths, shorter lengths will need to be cut by the purchaser.
C Purlins - Part cut any length under 2m **Z Purlin** - Any length under 2m is joined together with no part cut.



Z – Section Extreme Purlin

Z150 Purlin

PURLIN - EX_Z150 X 58 X 1.20 BMT: **EX_Z150_58_1.20G** (2.83kg/m)

PURLIN - EX_Z150 X 58 X 1.50 BMT: **EX_Z150_58_1.50G** (3.52kg/m)

PURLIN - EX_Z150 X 58 X 1.90 BMT: **EX_Z150_58_1.90G** (4.45kg/m)

PURLIN - EX_Z150 X 58 X 2.40 BMT: **EX_Z150_58_2.40G** (5.60kg/m)

Standard Pack: 20 Lengths

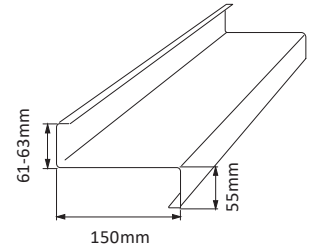

Z200 Purlin

PURLIN - EX_Z200 X 72 X 1.20 BMT: **EX_Z200_72_1.20G** (3.59kg/m)

PURLIN - EX_Z200 X 72 X 1.50 BMT: **EX_Z200_72_1.50G** (4.47kg/m)

PURLIN - EX_Z200 X 72 X 1.90 BMT: **EX_Z200_72_1.90G** (5.65kg/m)

PURLIN - EX_Z200 X 72 X 2.40 BMT: **EX_Z200_72_2.40G** (7.12kg/m)

Standard Pack: 20 Lengths

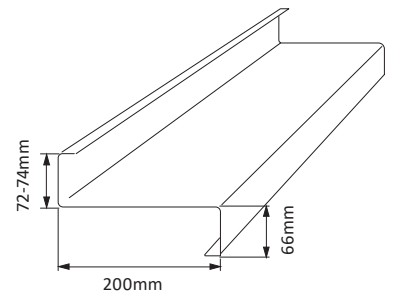

Z250 Purlin

PURLIN - EX_Z250 X 73 X 1.50 BMT: **EX_Z250_73_1.50G** (5.07kg/m)

PURLIN - EX_Z250 X 73 X 1.90 BMT: **EX_Z250_73_1.90G** (6.41kg/m)

PURLIN - EX_Z250 X 73 X 2.40 BMT: **EX_Z250_73_2.40G** (8.07kg/m)

Standard Pack: 20 Lengths

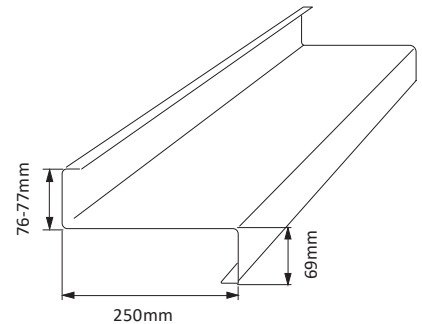

Z300 Purlin

PURLIN - EX_Z300 X 93 X 1.90 BMT: **EX_Z300_93_1.90G** (7.91kg/m)

PURLIN - EX_Z300 X 93 X 2.40 BMT: **EX_Z300_93_2.40G** (9.97kg/m)

PURLIN - EX_Z300 X 93 X 3.00 BMT: **EX_Z300_93_3.00G** (12.51kg/m)

Standard Pack: 20 Lengths

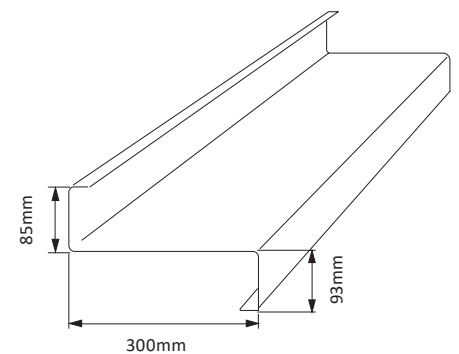

NOTE: C & Z Purlins are only manufactured down to 2m lengths, shorter lengths will need to be cut by the purchaser.
C Purlins - Part cut any length under 2m **Z Purlin** - Any length under 2m is joined together with no part cut.

Brackets

Angle Connector Bracket
ANGLE CONNECTOR - C100: MF-AC100 (0.19kg/ea.)
ANGLE CONNECTOR - C150: MF-AC150 (0.30kg/ea.)
ANGLE CONNECTOR - C200: MF-AC200 (0.39kg/ea.)
ANGLE CONNECTOR - C250: MF-AC250 (0.56kg/ea.)
ANGLE CONNECTOR - C300: MF-AC300 (0.69kg/ea.)
Standard Pack: 50 Brackets

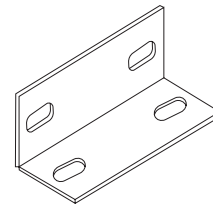

Angle Connector Bracket

General Purpose Bracket
GENERAL PURPOSE BRACKET C100: GPB100 (0.23kg/ea.)
GENERAL PURPOSE BRACKET C150: GPB150 (0.41kg/ea.)
GENERAL PURPOSE BRACKET C200: GPB200 (0.61kg/ea.)
GENERAL PURPOSE BRACKET C250: GPB250 (0.80kg/ea.)
GENERAL PURPOSE BRACKET C300: GPB300 (1.00kg/ea.)
Standard Pack: 50 Brackets

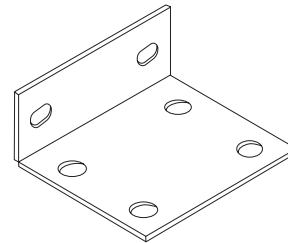

General Purpose Bracket



Hook Fast Purlin Bridging

Millform HookFast® Bridging System

(available to suit C/Z100, 150, 200 & 250)

Where strength matters



Adj Starter – Adjustable Female / Fascia Cleat

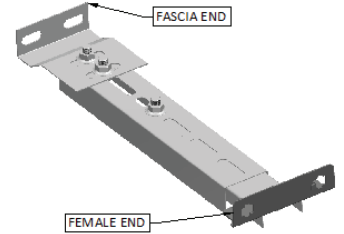

Starter – Bolted / Female

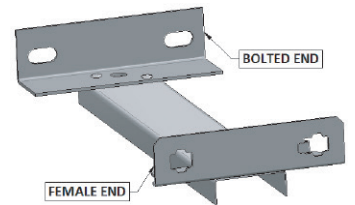

Intermediate – Male / Female

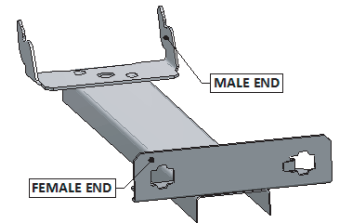

Finisher – Male / Bolted

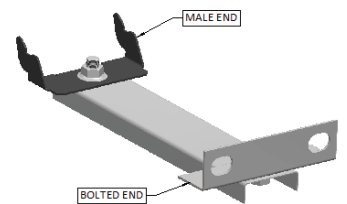

12 mm Sag Rod Ridge Tie (add 100 mm to centres)

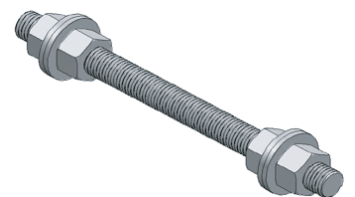

PRODUCT MANUAL — PURPOSE AND APPLICATION

How to Use This Manual

This manual lists detailed product capacities that should be considered during installation along with real applied loads. All spans are considered to be loaded concurrently, and allowances have not been made for uneven or skip loading. If loading conditions are likely to be inconsistent or vary from this manual, a structural engineer should be employed to verify compliance with AS/NZS 4600:2018.

Real loading capacity can vary widely, with reduced loading not enough to ensure competency. Member adequacy is also dependent on member profiles and movement application within the member span. Design actions can vary widely under applied loads, however, with each project design engineer needing to verify project specific material selection in compliance with AS/NZS 4600:2018 and AS/ANZ 1170 Assessed Loading.

Design Considerations and Assumptions

The information presented in this manual applies to limit state capacity. Any load amounts beyond tabulated totals will prevent the member from meeting its intended function. In this situation, potential outcomes include collapse and loss of structural integrity.

Limit state tables are listed for specific purlin combinations in order to affirm economic design solutions. In special projects, the following elements can be adjusted to optimise design: material specifications, bolt quantity, bolt specifications, bridging quantity, span range, lap length, end span sizes, cantilevers, and loading requirements.

All design calculations are based on AS/NZS 4600:2018 Cold Formed Steel Structures. All measurements are based on industry best practice.

Assumptions inherent in and validated by code provisions:

- The Z shaped section behaves as an equivalent C shaped channel.
- In regard to its initial displacement, the Z shaped section may be seen as physically attached to and acting with the sheeting incurring the loads.
- For Inward loading, full compressive bending

stress is allowed on the flange that is attached to the sheeting. The following diagram shows the centre span condition.

- For Outward loading, full compressive bending stress is allowed on the flange that is attached to the sheeting. The following diagram shows span support condition.
- For any sections or lengths that experience distortions or buckling effects, bending moment gradient and magnitude are considered.
- For all systems, loading distribution is assumed to be uniform and acting on all spans simultaneously.
- All section properties have been calculated with the holes deducted from the web.

LOADING CONDITIONS

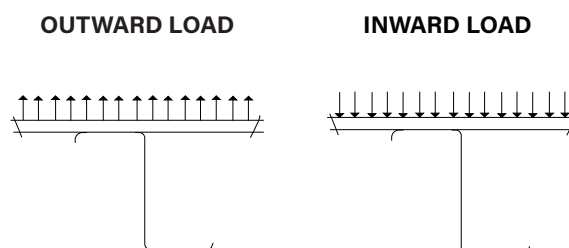

Design Considerations and Assumptions Disclaimer

This document is intended to provide accurate information relating to Millform C and Z *Extreme purlins*™. It does not attempt to provide a complete description of the products. It does not describe the suitability of materials for specific projects or applications. All published information is intended as a guide only. Millform Pty Ltd does not accept any liability for loss or damage resulting from the use of data in this document.

Where strength matters





DESIGN & SPECIFICATION

Hole Punching

Millform C and Z *Extreme purlin™* sections are typically supplied with hole punch measurements that comply with the AISC guide. Measurements are different in Victoria, however, with 150 mm sections punched with 70 mm centres in accordance with Structural Steel Fabricator Association Victoria guidelines.

Punched holes are needed at cleat supports, laps, bridging points, and other locations as specified on data sheets prior to manufacture. Our system is left-to-right cumulative from one end to ensure accuracy. A complete purlin length measurement is needed to enable a data entry dimensional check.

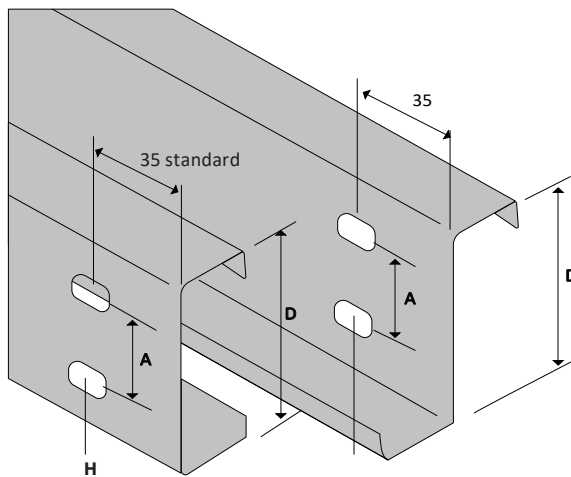

HOLE CENTRES

PURLIN SIZE	AISC CENTRES		STATE
	D mm	H mm	
100	40	18 x 22	ALL
150	60	18 x 22	ALL EXCEPT VICTORIA
200	110	18 x 22	ALL
250	160	18 x 22	ALL
300	210	18 x 22	ALL
350	260	18 x 22	ALL
400	310	18 x 22	ALL

Alternative hole sizes, shapes and centres are available. Please enquire with your local Millform branch.

Structural Lap Lengths

Millform Z sections feature one broad flange and one narrow flange in direct proportion. If both sections are the same size, and one section is rotated by 180 degrees, they can be fitted and will align with a bolt connection. This makes them suitable for lapping. While structural continuity enables improved economy, lapping helps to increase strength, improve load capacity, and enhance system rigidity. C sections can't be lapped.

When Z sections are lapped, there are two thicknesses installed over interior supports. Depending on the length of the lap, this can alter deflection and reaction coefficients along with bending movements. These elements are determined by a nominal lap of 10% span in all lapped spans. When a lighter internal section combines with a heavier gauge end span, the difference in thickness accounts for a maximum of two sections.

At more complex points with three or four lapped span configurations, the greater thickness exists in the end spans. Regardless of configuration, the structural lap at interior supports must provide enough structural continuity. Each lap end must be bolted, with one bolt placed through the flanges furthest from the cladding and another bolt placed through the webs near the flanges connected to the cladding.

Z sections can be used over simple spans and applied continuously over two or more shorter spans without laps. Z sections with a single lip turned outwards can be used with the ends butted in simple or continuous spans; however, these sections can't be overlapped.

In terms of bridging, three rows should be selected, with additional rows offering no benefits. Bridging should be selected and installed with a maximum un-braced length of 20 x D (purlin height) or 4,000 mm. This helps to enhance purlin performance and also assists with the installation of roof sheeting. A design engineer should assist in locating an ideal bridging location to the nearest 50 mm.

LAP LENGTHS

Nominal Section Size (mm)	Span (mm)	Lap Length (mm)
100	≤6000	600
	>6000	900
150, 200, 250	≤9000	900
	>9000 ≤12000	1200
300, 350	≤9000	900
	>9000 ≤12000	1200
	>1200 ≤1800	1800
	>18000	2400

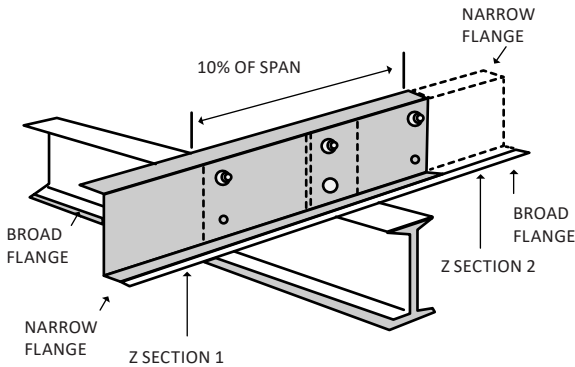

BRIDGING

The limit state capacity tables provide design solutions for an equal number of rows of bridging in each span. Provision is made for 0, 1, 2 or 3 rows.

RECOMMENDED MAX. BRIDGING SPACING

PURLIN SIZE MM	MAX. BRIDGING SPACING MM
100	2000
150	3000
200, 250, 300, 350, 400	4000

BRIDGING HOLE LOCATIONS

SINGLE OR INTERNAL SPANS

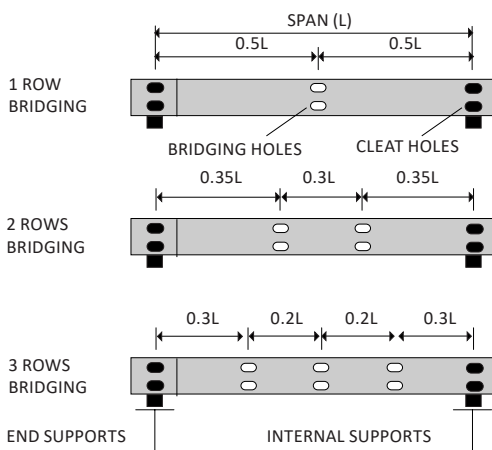

DOUBLE OR END SPANS

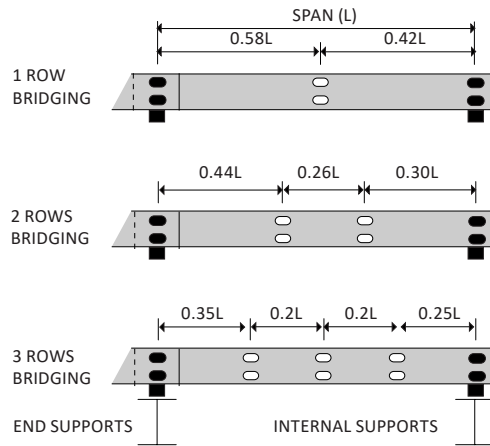

Member Weight

Limit state loads are measured in kN/m and make no allowance for the mass of the member. In some cases, limit state loads are limited by the bolting.

Deflection

Structural codes provide guidance surrounding deflections; however, there are no specific rules in place. It's important to consider the specific requirements of the structure in question. It may be necessary to design under multiple load combinations, with critical span loads calculated with a deflection of Span/150.

Cleat Connections

Limit state capacity for cleat connections is based on sections being fastened through the web to the cleats. When this occurs, the load is transferred through the section web. This connection can be either single section thickness, like it is for end connections, or as an internal support for continuous configurations. Connections with double section thickness occur at the internal support point of lapped configurations.

With this style of connection, two bolts are used, with the size and grade of each bolt based on the overall size and design load of the section. In many cases, it's possible to eliminate cleats and bolts through the bottom flange of the Z and C sections. Overall, the number of bolts is halved compared to conventional cleated mechanisms.

Single cleats are often used with Z sections, and double cleats are used with C sections. Double cleats are also applied when there is a high reaction load used to reduce bolt stress and shear. Extra care is needed in the case of hole detailing for double cleat applications to a single purlin. Industry standard sizes and purlin clearances are illustrated in the following table.



CLEAT NOMINAL DIMENSIONS - MM

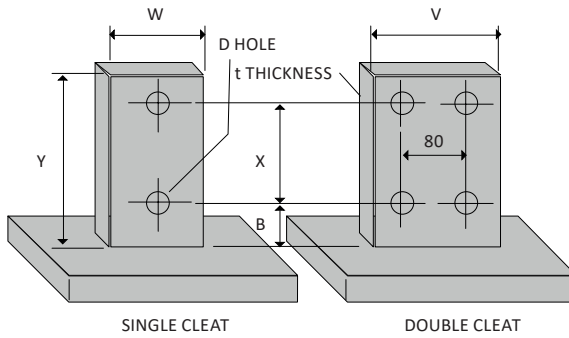

SIZE	X	B+	Y+	t	GAP	hd	W	V
100	40	40	105	8	10	18	50	130
150	60*	50†	145	8	10	18	60	140
200	110	55	195	8	10	18	60	140
250	160	55	245	8	10	18	60	140
300	210	65	305	12	20	22	60	140
350	260	65	355	12	20	22	60	140
400	310	75	405	12	20	22	60	104

* 70mm in VIC

† 50mm in VIC

+ When using down turned lip purlins or girts the lip length must be added to the dimension B and Y. Cleat lengths may be increased in some design situations (e.g. above an expansion joint).

As a guide, increase the cleat thickness by 2mm for each 40mm of additional length.

BOLTS

When you fasten sections to cleats, standard bolts are required. High strength bolts are also needed for some applications, with this situation marked in the limit state capacity tables. In these situations, the overall section capacity is not fully utilised, and an alternative configuration may be more economical. It may also be possible to change the spacing or increase the number of bolts in the section.

Purlin laps need to be bolted to the top web hole and lower flange holes at both ends of the lap. If only the web is bolted, excessive loads can be placed on roofing screws and structural integrity is compromised. It's important that all bolts are tightened prior to roof installation, and the design engineer ensures the correct size and grade of purlin bolts.



BOLT SPECIFICATION

NOMINAL SECTION SIZE MM	BOLT SPECIFICATION
100, 150, 200, 250	Standard M12 Purlin Bolt High Strength M12 Purlin Bolt
300, 350, 400	Standard M16 Purlin Bolt High Strength M16 Purlin Bolt

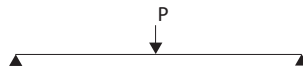
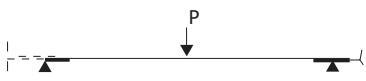

Point Loads (SEE TABLE OVER PAGE)

The limit state loads listed in the following tables are distributed evenly based on uniform values. There are key differences based on applications, with all design loads needing to be converted to ensure correct use. In some applications, design loads are point loads. Point-loaded configurations have been linked to uniformly loaded configurations and presented with the correct conversion. For continuous unlapped configurations, a different conversion formula is needed.

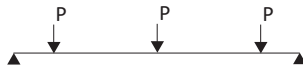
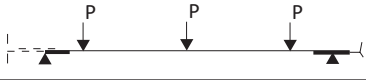
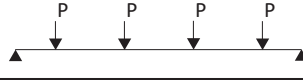
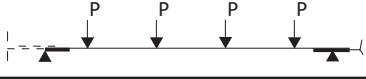
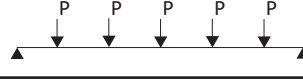
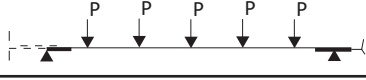
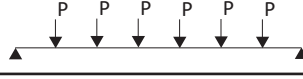
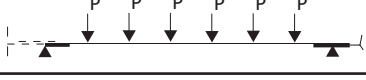
In the case of single spans, the formula given is accurate. For lapped spans, the accuracy of the conversion is dependent on the number of spans, their position in the continuity, and the lapping ratio. The lapped span formula shown is based on worst-case loading conditions, which means it can be safely applied for interior spans, end spans, and lapping ratios greater than 0:10. A separate set of conversion formula is needed for deflections.

LOADING CONDITION		DIAGRAM	CONVERSION FORMULA
SINGLE LOAD	Simple		$w = \frac{2P}{L}$
	Lapped		$w = \frac{2.22P}{L}$
2 LOADS	Simple		$w = \frac{2.67P}{L}$
	Lapped		$w = \frac{3.16P}{L}$
3 LOADS	Simple		$w = \frac{4P}{L}$
	Lapped		$w = \frac{3.78P}{L}$
4 LOADS	Simple		$w = \frac{4.80P}{L}$
	Lapped		$w = \frac{5.12P}{L}$
5 LOADS	Simple		$w = \frac{6P}{L}$
	Lapped		$w = \frac{6.65P}{L}$
6 OR MORE LOADS	Simple		$w = \frac{1.14P}{L}$
	Lapped		$w = \frac{1.22P}{L}$

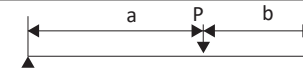
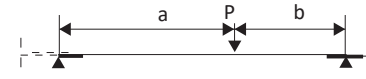
SINGLE ECCENTRIC & TWO SYMMETRICAL POINT LOADS

SINGLE ECCENTRIC POINT LOAD	Simple		$w = \frac{8abP}{L^3}$
	Lapped		$w = \frac{17.76ab^2P}{L^4}$
TWO SYMMETRICAL POINT LOADS	Simple		$w = \frac{8bP}{L^2}$
	Lapped		$w = \frac{9.45(2L-3b)P}{L^3}$

P = Single Point Load (kN)
 L = Span (m)
 a = Larger distance from support (m)
 b = Smaller distance from support (m)
 w = Equivalent uniform load (kN/m)
 N = Number of Point Loads over one span

Where strength matters



The tables shown below highlight the maximum limit state capacity of the sections. Capacities are based on loads that have been distributed uniformly, with any point loads needing to be converted. Required loads need to be established by a project designer using the correct building codes and standards. It's important to calculate the purlin and girt outward and inward loads based on the preferred span configuration. The **Hookfast®** bridging system can be used for 3 rows of bridging.

Where strength matters

SINGLE SPAN

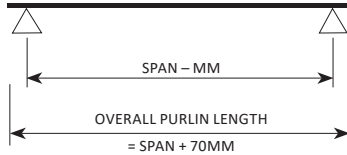

2 SPAN CONTINUOUS UNLAPPED

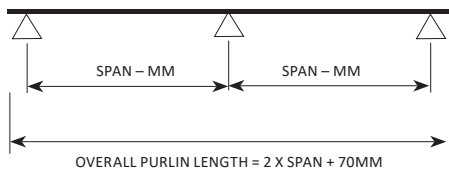

2 SPAN LAPPED

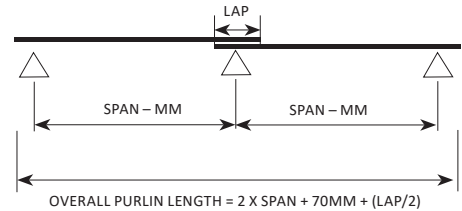

3 SPAN CONTINUOUS UNLAPPED

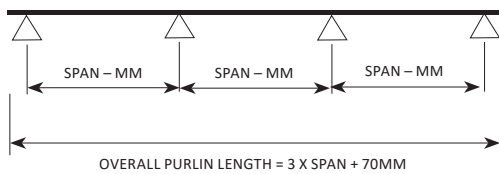

3 SPAN LAPPED

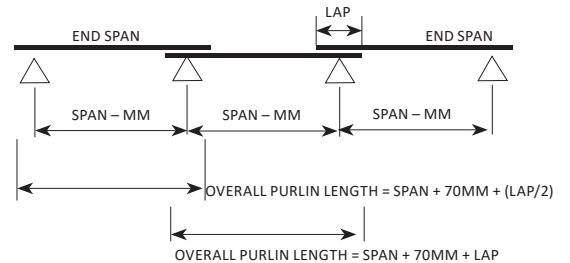

4 SPAN CONTINUOUS UNLAPPED

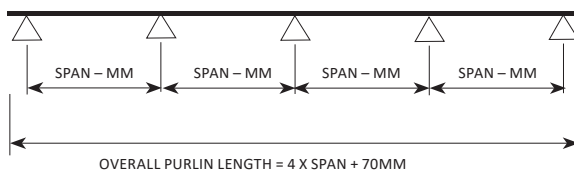

4 SPAN LAPPED

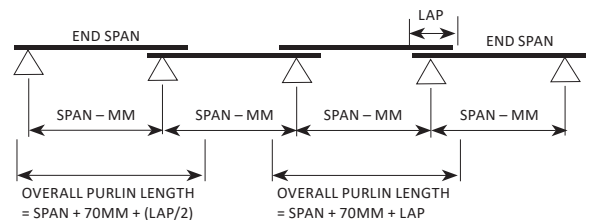

MILLFORM PURLIN SPAN TABLES & SECTION PROPERTIES FOR EXTREME C & Z PURLINS

The following section contains span tables and section properties tables.

Product Dimensions		Page
1.	TABLE 1.1 C&Z Extreme Purlin™ Dimensions	20
Purlin Spans Explained		
2.	TABLE 2.1 Purlin Spans Explained Scheme	21
Section Properties		
3.	TABLE 3.1 C Section Range	22
4.	TABLE 3.2 Z Section Range	23
Span Tables		
5.	TABLE 4.1 Single Span / End Span	24
6.	TABLE 4.2 Double Unlapped Span	26
7.	TABLE 4.3 Lapped One End	28
8.	TABLE 4.4 Lapped Both Ends (Continuous)	30

EXTREME
PURLIN™

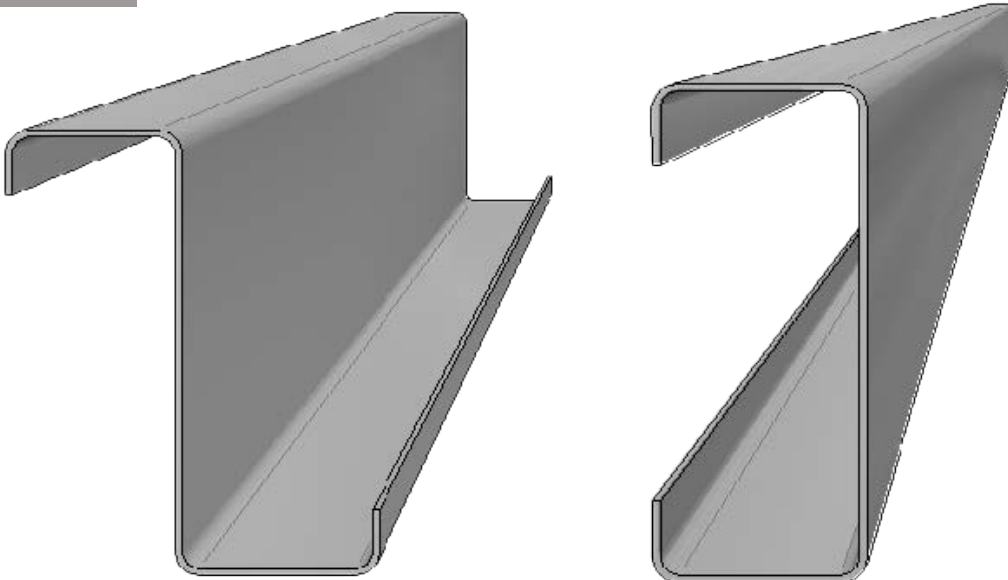



TABLE 1.1 Product Dimensions

Extreme "C" Purlins							Extreme "Z" Purlins					
Type	Overall Height	Flange	Lip Width	Thickness	Mpa	Kg/M	Type	Overall Height	Narrow Flange	Wide Flange	Lip Width	Thickness
EC15012	150	58	21.8	1.2	G500	2.89	EZ15012	151.7	55	61	20.9	1.2
EC15015	150	58	22.5	1.5	G450	3.59	EZ15015	152.0	55	61	21.5	1.5
EC15019	150	58	23.5	1.9	G450	4.52	EZ15019	152.4	55	62	21.8	1.9
EC15024	150	58	24.7	2.4	G450	5.67	EZ15024	152.9	55	63	22.2	2.4
EC20012	200	72	22.8	1.2	G500	3.68	EZ20012	201.7	66	72	24.9	1.2
EC20015	200	72	23.5	1.5	G450	4.56	EZ20015	202.0	66	72	25.5	1.5
EC20019	200	72	24.5	1.9	G450	5.74	EZ20019	202.4	66	73	25.8	1.9
EC20024	200	72	25.7	2.4	G450	7.21	EZ20024	202.9	66	74	26.2	2.4
EC25015	250	73	22.5	1.5	G450	5.17	EZ25015	252.0	69	76	22.0	1.5
EC25019	250	73	23.5	1.9	G450	6.51	EZ25019	252.4	69	76	22.8	1.9
EC25024	250	73	24.7	2.4	G450	8.17	EZ25024	252.9	69	77	23.2	2.4
EC30019	300	93	28.5	1.9	G450	8.04	EZ30019	302.4	85	93	31.3	1.9
EC30024	300	93	29.7	2.4	G450	10.1	EZ30024	302.9	85	93	32.2	2.4
EC30030	300	93	31.2	3.0	G450	12.6	EZ30030	303.5	85	95	32.4	3.0

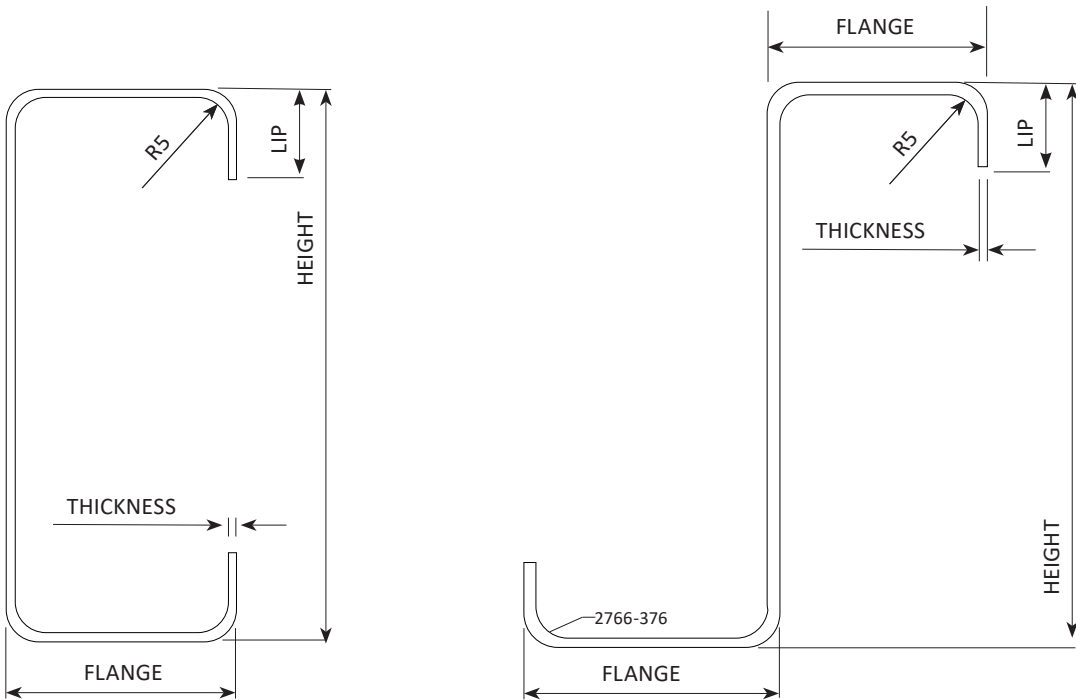
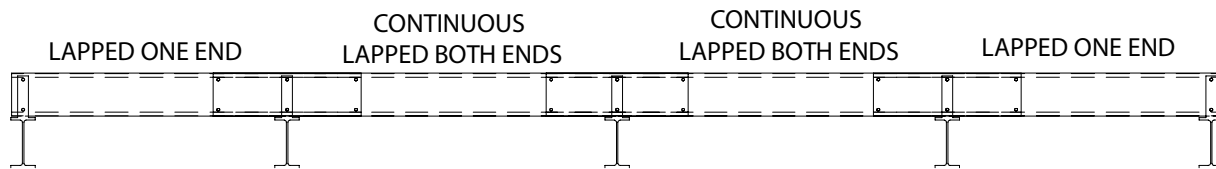
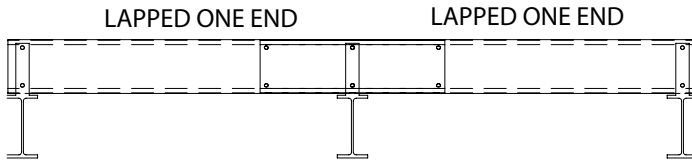
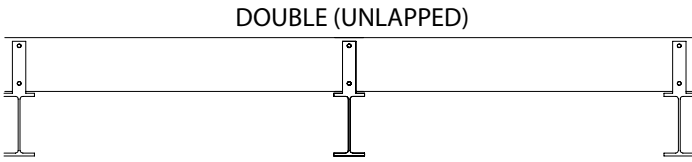
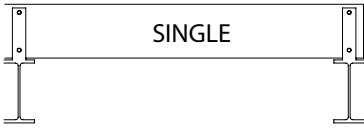
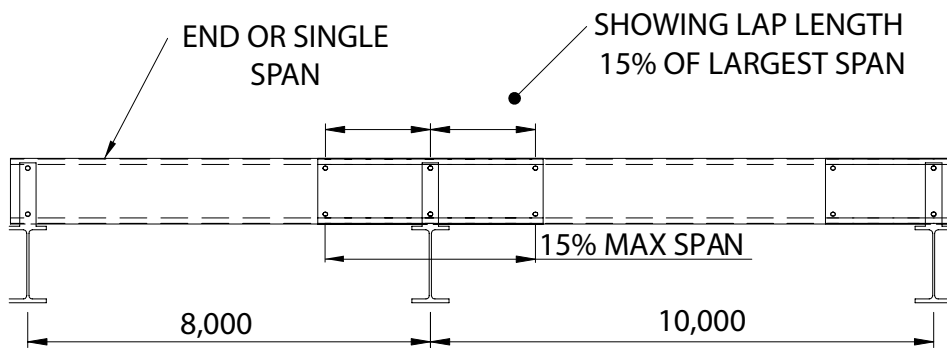

TABLE 2.1 Purlin Spans Explained



- SPAN VARIETIES
- 1 - SINGLE
 - 2 - DOUBLE (UNLAPPED)
 - 3 - LAPPED ONE END
 - 4 - CONTINUOUS - LAPPED BOTH ENDS



Where strength matters



MILLFORM EXTREME C PURLINS AND GIRTS SECTION PROPERTIES

	BMT	Area	Ixx	Iyy	Zxx	Zyy	rx	ry	Iw	J	βy	X _o	X'(CG)
	mm	mm ²	mm ⁴	mm ⁴	mm ³	mm ³	mm	mm	mm ⁶	mm ³		mm	mm
C15015	1.5	454	1605403	297533	21405	6983	59.44	24.36	7.80E+08	341	164	40.30	21.39
EFFECTIVE		370	1506871	242322	20092	5687							
C15019	1.9	575	1947487	346615	25966	8050	58.94	23.88	9.35E+08	690	185	40.35	20.94
EFFECTIVE		489	1947487	304978	25966	7083							
C15024	2.4	726	2364172	404638	31522	9315	58.44	23.39	1.11E+09	1383	204	40.30	20.56
EFFECTIVE		614	2364172	363885	31522	8377							
C20012	1.2	456	2934938	435450	29349	8385	79.27	29.10	2.07E+09	220	213	46.77	24.07
EFFECTIVE		399	2934938	370898	29349	7142							
C20015	1.5	555	3526558	396568	34744	7171	79.27	29.10	3.06E+09	415	223	55.00	21.00
EFFECTIVE		450	3526558	396568	37744	7171							
C20019	1.9	722	4325400	594282	43254	11225	79.70	26.70	3.00E+09	867	269	46.83	23.06
EFFECTIVE		610	4103791	504433	41038	9528							
C20024	2.4	912	5292915	700896	52929	13139	77.62	27.52	3.61E+09	1741	293	46.75	22.66
EFFECTIVE		796	5292915	638203	52929	11964							
C25015	1.5	653	6050100	563209	48401	10372	96.19	28.35	4.36E+09	490	294	44.67	21.70
EFFECTIVE		532	5363419	447984	42907	8250							
C25019	1.9	827	7424877	665628	59399	12155	95.54	27.81	5.30E+09	994	331	44.61	21.24
EFFECTIVE		710	7077288	571755	56618	10441							
C25024	2.4	1045	9114807	788034	72918	14292	94.93	27.28	6.41E+09	1996	364	44.48	20.86
EFFECTIVE		923	9114807	722597	72918	13105							
C30024	2.4	1307	16870995	1660935	112473	24705	115.12	35.47	2.25E+10	2498	435	61.74	27.77
EFFECTIVE		1110	15958247	1477820	106388	21981							
C30030	3	1633	20658984	1983978	137727	29391	114.56	34.98	2.71E+10	4864	468	61.63	27.50
EFFECTIVE		1445	20658984	1882046	137727	27881							

Both Gross Section Properties & Effective Section Properties shown on alternate rows.

MATERIAL PROPERTIES

	BMT	1.0mm	>1.0
F _y	mPa	550	450
E	mPa	2.00E+05	
G	mPa	8.00E+04	

Where strength matters



TABLE 3.2 Z SECTION RANGE



MILLFORM EXTREME Z PURLINS AND GIRTS SECTION PROPERTIES

	BMT	Area	Ixx	Iyy	Zxx	Zyy	rx	ry	Iw	J	βy	X _o	X*(CG)
	mm	mm ²	mm ⁴	mm ⁴	mm ³	mm ³	mm	mm	mm ⁶	mm ³		mm	mm
Z15015	1.5	454	1846704	526909	24623	8233	60.69	34.08	5.15E+09	341	126	0.00	0.00
EFFECTIVE		370	1748172	497638	23309	7776							
Z15019	1.9	575	2186120	613034	29148	9579	59.97	32.66	6.36E+09	690	149	0.00	0.00
EFFECTIVE		489	2186120	613034	29148	9579							
Z15024	2.4	726	2599491	716793	34660	11200	59.30	31.43	7.78E+09	1383	171	0.00	0.00
EFFECTIVE		614	2599491	716793	34660	11200							
Z20012	1.2	456	3375598	733338	33756	9649	81.02	40.10	1.40E+10	220	164	0.00	0.00
EFFECTIVE		399	3375598	733338	33756	9649							
Z20015	1.5	559	3482871	620373	34900	10216	78.80	33	4.38E+10	418	193	0.00	0.00
EFFECTIVE		481	3482871	620373	34900	10216							
Z20019	1.9	722	4759734	995543	47597	13099	79.39	37.13	2.15E+10	867	224	0.00	0.00
EFFECTIVE		610	4538125	941810	45381	12392							
Z20024	2.4	912	5722758	1175383	57228	15466	78.63	35.90	2.64E+10	1741	252	0.00	0.00
EFFECTIVE		796	5722758	1175383	57228	15466							
Z25015	1.5	653	6743561	893098	53948	11751	98.08	36.98	3.13E+10	490	244	0.00	0.00
EFFECTIVE		532	6056880	792428	48455	10427							
Z25019	1.9	827	8113787	1053364	64910	13860	97.11	35.68	3.88E+10	994	283	0.00	0.00
EFFECTIVE		710	7766197	999631	62130	13153							
Z25024	2.4	1045	9798048	1247958	78384	16421	96.21	34.56	4.78E+10	1996	319	0.00	0.00
EFFECTIVE		923	9798048	1247958	78384	16421							
Z30024	2.4	1307	17866509	2678004	119110	28190	116.34	45.27	1.69E+11	2498	392	0.00	0.00
EFFECTIVE		1110	16953761	2521739	113025	26545							
Z30030	3	1633	21646314	3207785	144309	33766	115.55	44.32	2.06E+11	4864	430	0.00	0.00
EFFECTIVE		1445	21646314	3207785	144309	33766							

Both Gross Section Properties & Effective Section Properties shown on alternate rows.

MATERIAL PROPERTIES

	BMT	1.0mm	>1.0
F _y	mPa	550	450
E	mPa	2.00E+05	
G	mPa	8.00E+04	

Where strength matters



TABLE 4.1 SINGLE / END SPAN

Where strength matters

Span	EC/EZ_I50-12						EC/EZ_I50-15						EC/EZ_I50-19						EC/EZ_I50-24						Span	
	In	L/ 150	Outward				In	L/ 150	Outward				In	L/ 150	Outward				In	L/ 150	Outward					
			0	1	2	3			0	1	2	3			0	1	2	3			0	1	2	3		
2500	6.44	6.44	6.44	6.44	6.44	6.44	8.31	9.80	8.07	8.31	8.31	8.31	11.6	12.6	11.2	11.6	11.6	11.6	11.6	15.8	16.0	14.1	15.8	15.8	15.8	2500
3000	4.47	4.44	3.97	4.47	4.47	4.47	5.77	5.68	5.02	5.77	5.77	5.77	8.03	7.30	6.66	8.03	8.03	8.03	11.0	9.27	8.51	11.0	11.0	11.0	3000	
3500	3.29	2.80	2.34	3.29	3.29	3.29	4.24	3.57	3.10	4.24	4.24	4.24	5.90	4.60	4.02	5.90	5.90	5.90	8.05	5.84	5.24	8.05	8.05	8.05	3500	
4000	2.52	1.88	1.44	2.52	2.52	2.52	3.25	2.40	1.88	3.25	3.25	3.25	4.52	3.08	2.45	4.52	4.52	4.52	6.16	3.91	3.25	5.88	6.16	6.16	4000	
4500	2.03	1.34	0.95	2.03	2.03	2.03	2.61	1.72	1.22	2.54	2.61	2.61	3.64	2.21	1.62	3.51	3.64	3.64	4.97	2.80	2.17	4.45	4.97	4.97	4500	
5000	1.65	0.98	0.64	1.57	1.65	1.65	2.12	1.25	0.83	1.93	2.12	2.12	2.95	1.61	1.10	2.63	2.95	2.95	4.02	2.05	1.50	3.36	4.02	4.02	5000	
5500	1.36	0.74		1.17	1.36	1.36	1.76	0.94	0.58	1.50	1.76	1.76	2.43	1.21	0.79	1.98	2.43	2.43	3.33	1.54	1.08	2.55	3.28	3.33	5500	
6000	1.15	0.57		0.86	1.15	1.15	1.48	0.73		1.14	1.48	1.48	2.05	0.94	0.58	1.49	2.05	2.05	2.79	1.18	0.81	1.95	2.65	2.79	6000	
6500	0.97	0.45		0.64	0.97	0.97	1.26	0.57		0.85	1.23	1.26	1.75	0.74		1.11	1.71	1.75	2.38	0.93	0.62	1.48	2.16	2.38	6500	
7000	0.84	0.37		0.84	0.84	1.09	0.46		0.63	1.02	1.09	1.50	0.59		0.84	1.40	1.50	2.06	0.75		1.12	1.78	2.06	7000		
7500	0.74	0.29		0.68	0.74	0.94	0.38			0.85	0.94	1.32	0.48		0.65	1.15	1.32	1.79	0.61		0.87	1.47	1.77	7500		
8000	0.64	0.24		0.56	0.64	0.83	0.31			0.72	0.83	1.15	0.40		0.95	1.15	1.57	0.50			0.69	1.22	1.51	8000		
8500					0.58	0.75	0.27			0.61	0.75	1.05	0.34		0.80	1.05	1.43	0.43			0.56	1.04	1.32	8500		
9000					0.67	0.23				0.66	0.93	0.29			0.66	0.90	1.27	0.36			0.86	1.14	9000			
9500										0.57	0.84	0.25			0.54	0.78	1.13	0.31			0.71	0.99	9500			
10000															0.68	1.01	0.27				0.59	0.87	10000			
10500																0.58	0.92	0.23					0.75	10500		
11000																							0.66	11000		
11500																							0.57	11500		
12000																								12000		
12500																								12500		
13000																								13000		
13500																								13500		
14000																								14000		
14500																								14500		
15000																								15000		

Span	EC/EZ_200-12						EC/EZ_200-15						EC/EZ_200-19						EC/EZ_200-24						Span
	In	L/ 150	Outward				In	L/ 150	Outward				In	L/ 150	Outward				In	L/ 150	Outward				
			0	1	2	3			0	1	2	3			0	1	2	3			0	1	2	3	
2500	6.52	16.2	6.52	6.52	6.52	6.52	12.1	21.0	12.1	12.1	12.1	12.1	17.6	27.8	17.6	17.6	17.6	17.6	24.2	35.3	24.2	24.2	24.2	24.2	2500
3000	5.43	9.35	5.43	5.43	5.43	5.43	8.39	12.2	8.39	8.39	8.39	8.39	12.3	16.1	11.8	12.3	12.3	12.3	16.9	20.5	16.1	16.9	16.9	16.9	3000
3500	4.66	5.89	4.19	4.66	4.66	4.66	6.17	7.65	5.58	6.17	6.17	6.17	8.99	10.2	7.91	8.99	8.99	8.99	12.4	12.9	10.4	12.3	12.4	12.3	3500
4000	3.63	3.95	2.83	3.63	3.63	3.63	4.72	5.13	3.65	4.72	4.72	4.72	6.88	6.79	5.33	6.88	6.88	6.88	9.45	8.61	6.76	9.45	9.45	9.45	4000
4500	2.93	2.83	1.91	2.93	2.93	2.93	3.81	3.68	2.47	3.81	3.81	3.81	5.54	4.87	3.49	5.54	5.54	5.54	7.62	6.18	4.47	7.62	7.62	7.62	4500
5000	2.37	2.07	1.30	2.37	2.37	2.37	3.09	2.68	1.71	3.09	3.09	3.09	4.50	3.55	2.34	4.50	4.50	4.50	6.17	4.50	3.01	6.17	6.17	6.17	5000
5500	1.96	1.55	0.93	1.89	1.96	1.96	2.55	2.01	1.19	2.55	2.55	2.55	3.72	2.67	1.63	3.55	3.72	3.72	5.10	3.38	2.12	4.85	5.10	5.10	5500
6000	1.65	1.20	0.67	1.51	1.65	1.65	2.15	1.56	0.85	2.02	2.15	2.15	3.13	2.06	1.18	2.84	3.13	3.13	4.29	2.60	1.55	3.80	4.29	4.29	6000
6500	1.40	0.95		1.20	1.40	1.40	1.82	1.23	0.64	1.59	1.82	1.82	2.66	1.62	0.88	2.29	2.66	2.66	3.65	2.05	1.16	2.99	3.65	3.65	6500
7000	1.22	0.75		0.96	1.22	1.22	1.58	0.98		1.25	1.58	1.58	2.30	1.30	0.67	1.84	2.30	2.30	3.15	1.65	0.89	2.36	3.15	3.15	7000
7500	1.06	0.62		0.76	1.05	1.06	1.37	0.80		0.98	1.37	1.37	2.00	1.05		1.44	2.00	2.00	2.75	1.34	0.69	1.84	2.73	2.75	7500
8000	0.93	0.51		0.61	0.90	0.93	1.20	0.66		0.78	1.20	1.20	1.76	0.87		1.11	1.70	1.76	2.42	1.10	0.56	1.44	2.32	2.42	8000
8500	0.84	0.43		0.79	0.84	1.09	0.56		0.66	1.06	1.09	1.59	0.74		0.90	1.47	1.59	2.18	0.94		1.17	1.99	2.18	8500	
9000	0.75	0.36		0.67	0.75	0.97	0.47		0.90	0.97	1.42	0.63		0.72	1.27	1.42	1.94	0.79		0.94	1.69	1.94	9000		
9500	0.67	0.31		0.58	0.67	0.88	0.41		0.76	0.88	1.27	0.53		0.59	1.10	1.27	1.74	0.68		0.77	1.44	1.74	9500		
10000	0.61	0.27		0.61	0.78	0.34			0.65	0.78	1.15	0.46			0.96	1.15	1.58	0.58		0.63	1.23	1.58	10000		
10500	0.55	0.24		0.54	0.72	0.30			0.55	0.72	1.04	0.40			0.82	1.03	1.43	0.50			1.04	1.41	10500		
11000					0.66	0.26			0.66	0.95	0.34			0.68	0.91	1.30	0.43				0.88	1.24	11000		
11500					0.60	0.23			0.58	0.87	0.30			0.58	0.82	1.20	0.38				0.75	1.10	11500		
12000										0.80	0.27				0.73	1.09	0.34				0.63	0.98	12000		
12500										0.73	0.24				0.66	1.01	0.30				0.54	0.87	12500		
13000															0.59	0.94	0.27					0.77	13000		
13500																0.86	0.24					0.69	13500		
14000																						0.61	14000		
14500																						0.54	14500		
15000																							15000		



TABLE 4.1 SINGLE / END SPAN

Span	EC/EZ_250-15						EC/EZ_250-19						EC/EZ_250-24						Span
	In	L/150	Outward				In	L/150	Outward				In	L/150	Outward				
			0	1	2	3			0	1	2	3			0	1	2	3	
2500	10.0	35.3	10.0	10.0	10.0	10.0	20.5	46.2	20.5	20.5	20.5	20.5	31.3	60.1	31.3	31.3	31.3	31.3	2500
3000	8.34	20.4	8.34	8.34	8.34	8.34	15.4	26.7	15.4	15.4	15.4	15.4	21.7	34.7	21.3	21.7	21.7	21.7	3000
3500	7.15	12.9	7.15	7.15	7.15	7.15	11.4	16.8	10.3	11.4	11.4	11.4	16.0	22.0	14.0	16.0	16.0	16.0	3500
4000	6.11	8.59	5.02	6.11	6.11	6.11	8.67	11.3	6.88	8.67	8.67	8.67	12.2	14.7	9.03	12.2	12.2	12.2	4000
4500	4.92	6.16	3.42	4.92	4.92	4.92	6.98	8.07	4.58	6.98	6.98	6.98	9.82	10.5	5.90	9.82	9.82	9.82	4500
5000	3.99	4.49	2.38	3.99	3.99	3.99	5.65	5.88	3.06	5.65	5.65	5.65	7.96	7.66	3.95	7.96	7.96	7.96	5000
5500	3.30	3.37	1.65	3.24	3.30	3.30	4.68	4.42	2.12	4.68	4.68	4.68	6.57	5.75	2.76	6.42	6.57	6.57	5500
6000	2.77	2.60	1.18	2.60	2.77	2.77	3.93	3.41	1.52	3.68	3.93	3.93	5.53	4.43	1.99	5.07	5.53	5.53	6000
6500	2.36	2.04	0.87	2.10	2.36	2.36	3.35	2.69	1.13	2.94	3.35	3.35	4.71	3.49	1.48	4.03	4.71	4.71	6500
7000	2.04	1.64	0.65	1.70	2.04	2.04	2.89	2.15	0.85	2.36	2.89	2.89	4.06	2.80	1.13	3.14	4.06	4.06	7000
7500	1.77	1.33		1.37	1.77	1.77	2.52	1.77	0.66	1.87	2.52	2.52	3.54	2.27	0.88	2.43	3.54	3.54	7500
8000	1.56	1.10		1.09	1.54	1.56	2.21	1.44	0.52	1.46	2.21	2.21	3.11	1.88	0.70	1.90	3.06	3.11	8000
8500	1.41	0.94		0.90	1.35	1.41	2.00	1.22		1.17	1.93	2.00	2.81	1.60	0.57	1.53	2.65	2.81	8500
9000	1.26	0.79		0.73	1.17	1.26	1.78	1.03		0.94	1.64	1.78	2.50	1.34		1.23	2.26	2.50	9000
9500	1.13	0.68		0.59	1.01	1.13	1.60	0.88		0.76	1.41	1.60	2.25	1.14		1.00	1.93	2.25	9500
10000	1.02	0.58			0.88	1.02	1.44	0.75		0.63	1.21	1.44	2.03	0.97		0.82	1.64	2.03	10000
10500	0.93	0.50			0.76	0.93	1.31	0.66			1.05	1.31	1.84	0.85		0.68	1.39	1.84	10500
11000	0.84	0.44			0.66	0.83	1.19	0.57			0.89	1.19	1.68	0.74		0.57	1.16	1.64	11000
11500	0.77	0.38			0.56	0.74	1.10	0.50			0.75	1.07	1.53	0.65			0.97	1.46	11500
12000	0.71	0.34				0.67	1.00	0.44			0.64	0.95	1.42	0.57			0.83	1.30	12000
12500	0.66	0.30				0.60	0.93	0.39			0.54	0.85	1.30	0.50			0.71	1.16	12500
13000	0.60	0.27				0.54	0.86	0.34				0.76	1.21	0.45			0.61	1.04	13000
13500							0.79	0.31				0.68	1.12	0.41				0.92	13500
14000							0.74	0.28				0.60	1.04	0.36				0.81	14000
14500							0.69	0.25				0.54	0.96	0.32				0.71	14500
15000													0.90	0.29				0.63	15000

Span	EC/EZ_300-19						EC/EZ_300-24						EC/EZ_300-30						Span	
	In	L/150	Outward				In	L/150	Outward				In	L/150	Outward					
			0	1	2	3			0	1	2	3			0	1	2	3		
2500																				2500
3000																				3000
3500																				3500
4000	10.6	19.8	10.6	10.6	10.6	10.6	16.7	26.0	16.2	16.7	16.7	16.7	23.6	33.4	22.7	23.6	23.6	23.6	4000	
4500	9.49	14.2	8.66	9.49	9.49	9.49	13.5	18.6	11.9	13.5	13.5	13.5	19.0	23.9	16.7	19.0	19.0	19.0	4500	
5000	7.69	10.4	6.49	7.69	7.69	7.69	10.9	13.6	8.63	10.9	10.9	10.9	15.4	17.5	11.8	15.4	15.4	15.4	5000	
5500	6.35	7.76	4.67	6.35	6.35	6.35	8.99	10.2	6.31	8.99	8.99	8.99	12.7	13.2	8.34	12.8	12.8	12.8	5500	
6000	5.34	5.97	3.43	5.34	5.34	5.34	7.56	7.83	4.53	7.56	7.56	7.56	10.7	10.1	5.98	10.7	10.7	10.7	6000	
6500	4.56	4.70	2.58	4.56	4.56	4.56	6.44	6.16	3.33	6.44	6.44	6.44	9.08	7.95	4.41	9.08	9.08	9.08	6500	
7000	3.93	3.76	1.95	3.87	3.93	3.93	5.56	4.94	2.51	5.51	5.56	5.56	7.83	6.36	3.33	7.69	7.83	7.83	7000	
7500	3.42	3.06	1.49	3.27	3.42	3.42	4.84	4.01	1.93	4.57	4.84	4.84	6.83	5.17	2.57	6.45	6.83	6.83	7500	
8000	3.01	2.52	1.17	2.77	3.01	3.01	4.25	3.31	1.52	3.81	4.25	4.25	6.00	4.27	2.02	5.39	6.00	6.00	8000	
8500	2.72	2.14	0.94	2.40	2.72	2.72	3.84	2.81	1.23	3.24	3.84	3.84	5.41	3.62	1.65	4.56	5.41	5.41	8500	
9000	2.42	1.80	0.76	2.05	2.42	2.42	3.43	2.37	0.99	2.73	3.43	3.43	4.83	3.05	1.33	3.77	4.83	4.83	9000	
9500	2.17	1.54	0.62	1.70	2.17	2.17	3.08	2.01	0.81	2.30	3.08	3.08	4.34	2.60	1.10	3.10	4.34	4.34	9500	
10000	1.96	1.32		1.41	1.96	1.96	2.77	1.73	0.67	1.92	2.77	2.77	3.92	2.23	0.91	2.56	3.89	3.92	10000	
10500	1.78	1.14		1.18	1.74	1.78	2.52	1.49	0.56	1.59	2.47	2.52	3.56	1.92	0.76	2.11	3.45	3.56	10500	
11000	1.63	0.99		1.00	1.55	1.63	2.30	1.30		1.32	2.17	2.30	3.24	1.67	0.65	1.77	3.06	3.24	11000	
11500	1.49	0.87		0.86	1.38	1.49	2.10	1.13		1.11	1.92	2.10	2.97	1.47	0.55	1.49	2.71	2.97	11500	
12000	1.36	0.76		0.73	1.25	1.36	1.93	1.00		0.94	1.69	1.93	2.72	1.29		1.26	2.40	2.72	12000	
12500	1.26	0.68		0.63	1.11	1.26	1.78	0.89		0.81	1.50	1.78	2.50	1.14		1.08	2.11	2.50	12500	
13000	1.16	0.60		0.53	0.99	1.16	1.64	0.79		0.69	1.34	1.64	2.32	1.02		0.93	1.86	2.32	13000	
13500	1.08	0.54			0.89	1.08	1.53	0.70		0.60	1.19	1.53	2.13	0.91		0.81	1.63	2.14	13500	
14000	1.00	0.49			0.78	0.99	1.42	0.64			1.06	1.41	1.98	0.82		0.70	1.43	1.97	14000	
14500	0.94	0.44			0.69	0.91	1.32	0.58			0.93	1.28	1.83	0.73		0.62	1.25	1.81	14500	
15000	0.88	0.39			0.60	0.84	1.24	0.51			0.82	1.18	1.69	0.67		0.54	1.10	1.65	15000	

Where strength matters



Where strength matters

Span	EC/EZ_I50-12						EC/EZ_I50-15						EC/EZ_I50-19						EC/EZ_I50-24						Span
	In	L/150	Outward				In	L/150	Outward				In	L/150	Outward				In	L/150	Outward				
			0	1	2	3			0	1	2	3			0	1	2	3			0	1	2	3	
2500	5.35	18.5	5.35	5.35	5.35	5.35	8.13	23.7	8.13	8.13	8.13	8.13	11.6	30.5	11.6	11.6	11.6	11.6	15.8	38.6	15.8	15.8	15.8	15.8	2500
3000	4.10	10.8	4.10	4.10	4.10	4.10	5.77	13.7	5.77	5.77	5.77	5.77	8.03	17.6	8.03	8.03	8.03	8.03	11.0	22.4	11.0	11.0	11.0	11.0	3000
3500	3.22	6.75	3.22	3.22	3.22	3.22	4.24	8.61	4.24	4.24	4.24	4.24	5.90	11.1	5.90	5.90	5.90	5.90	8.05	14.1	8.05	8.05	8.05	8.05	3500
4000	2.52	4.53	2.52	2.52	2.52	2.52	3.25	5.77	3.25	3.25	3.25	3.25	4.52	7.42	4.52	4.52	4.52	4.52	6.16	9.43	6.04	6.16	6.16	6.16	4000
4500	2.03	3.24	2.03	2.03	2.03	2.03	2.61	4.14	2.61	2.61	2.61	2.61	3.64	5.32	3.64	3.64	3.64	3.64	4.97	6.75	4.64	4.97	4.97	4.97	4500
5000	1.65	2.36	1.65	1.65	1.65	1.65	2.12	3.02	2.06	2.12	2.12	2.12	2.95	3.88	2.82	2.95	2.95	2.95	4.02	4.93	3.57	4.02	4.02	4.02	5000
5500	1.36	1.76	1.31	1.36	1.36	1.36	1.76	2.26	1.61	1.76	1.76	1.76	2.43	2.91	2.19	2.43	2.43	2.43	3.33	3.70	2.79	3.33	3.33	3.33	5500
6000	1.15	1.37	1.02	1.15	1.15	1.15	1.48	1.75	1.29	1.48	1.48	1.48	2.05	2.25	1.72	2.05	2.05	2.05	2.79	2.85	2.20	2.78	2.79	2.79	6000
6500	0.99	1.10	0.81	0.99	0.99	0.99	1.29	1.40	1.06	1.29	1.29	1.29	1.79	1.81	1.39	1.79	1.79	1.79	2.42	2.29	1.79	2.35	2.42	2.42	6500
7000	0.85	0.89	0.62	0.85	0.85	0.85	1.11	1.12	0.84	1.11	1.11	1.11	1.53	1.45	1.09	1.53	1.53	1.53	2.10	1.84	1.44	1.96	2.10	2.10	7000
7500	0.75	0.72		0.75	0.75	0.75	0.96	0.92	0.66	0.94	0.96	0.96	1.34	1.17	0.87	1.30	1.34	1.34	1.82	1.49	1.15	1.65	1.82	1.82	7500
8000	0.66	0.59		0.64	0.66	0.66	0.85	0.75		0.79	0.85	0.85	1.17	0.96	0.69	1.09	1.17	1.17	1.60	1.23	0.93	1.39	1.60	1.60	8000
8500	0.58	0.50		0.55	0.58	0.58	0.75	0.63		0.68	0.75	0.75	1.05	0.81	0.56	0.92	1.05	1.05	1.43	1.03	0.76	1.18	1.39	1.43	8500
9000																									9000
9500																									9500
10000																									10000
10500																									10500
11000																									11000
11500																									11500
12000																									12000
12500																									12500
13000																									13000
13500																									13500
14000																									14000
14500																									14500
15000																									15000

Span	EC/EZ_200-12						EC/EZ_200-15						EC/EZ_200-19						EC/EZ_200-24						Span
	In	L/150	Outward				In	L/150	Outward				In	L/150	Outward				In	L/150	Outward				
			0	1	2	3			0	1	2	3			0	1	2	3			0	1	2	3	
2500	4.73	39.0	4.73	4.73	4.73	4.73	8.39	50.6	8.39	8.39	8.39	8.39	12.9	67.1	12.9	12.9	12.9	12.9	16.1	85.0	16.1	16.1	16.1	16.1	2500
3000	3.79	22.6	3.79	3.79	3.79	3.79	6.55	29.3	6.55	6.55	6.55	6.55	10.7	38.8	10.7	10.7	10.7	10.7	13.4	49.3	13.4	13.4	13.4	13.4	3000
3500	3.12	14.3	3.12	3.12	3.12	3.12	5.24	18.5	5.24	5.24	5.24	5.24	8.79	24.5	8.79	8.79	8.79	8.79	11.5	31.1	11.5	11.5	11.5	11.5	3500
4000	2.62	9.51	2.62	2.62	2.62	2.62	4.27	12.4	4.27	4.27	4.27	4.27	6.88	16.4	6.88	6.88	6.88	6.88	9.45	20.8	9.45	9.45	9.45	9.45	4000
4500	2.26	6.81	2.26	2.26	2.26	2.26	3.62	8.85	3.62	3.62	3.62	3.62	5.54	11.8	5.54	5.54	5.54	5.54	7.62	14.9	7.62	7.62	7.62	7.62	4500
5000	1.95	4.97	1.95	1.95	1.95	1.95	3.06	6.46	3.06	3.06	3.06	3.06	4.50	8.55	4.50	4.50	4.50	4.50	6.17	10.9	6.17	6.17	6.17	6.17	5000
5500	1.69	3.73	1.69	1.69	1.69	1.69	2.55	4.85	2.55	2.55	2.55	2.55	3.72	6.42	3.70	3.70	3.70	3.70	5.10	8.15	5.04	5.10	5.10	5.10	5500
6000	1.48	2.87	1.48	1.48	1.48	1.48	2.15	3.74	2.15	2.15	2.15	2.15	3.13	4.95	2.97	3.13	3.13	3.13	4.29	6.28	4.03	4.29	4.29	4.29	6000
6500	1.34	2.31	1.32	1.34	1.34	1.34	1.86	3.00	1.79	1.86	1.86	1.86	2.71	3.97	2.48	2.71	2.71	2.71	3.72	5.04	3.31	3.72	3.72	3.72	6500
7000	1.18	1.85	1.09	1.18	1.18	1.18	1.61	2.40	1.45	1.61	1.61	1.61	2.34	3.18	2.05	2.34	2.34	2.34	3.21	4.04	2.69	3.21	3.21	3.21	7000
7500	1.05	1.50	0.90	1.05	1.05	1.05	1.40	1.95	1.17	1.40	1.40	1.40	2.03	2.58	1.71	2.03	2.03	2.03	2.80	3.28	2.18	2.80	2.80	2.80	7500
8000	0.94	1.24	0.74	0.94	0.94	0.94	1.23	1.61	0.95	1.23	1.23	1.23	1.79	2.13	1.40	1.79	1.79	1.79	2.47	2.71	1.77	2.47	2.47	2.47	8000
8500	0.84	1.04	0.61	0.84	0.84	0.84	1.09	1.34	0.78	1.09	1.09	1.09	1.59	1.78	1.13	1.58	1.59	1.59	2.18	2.26	1.45	2.16	2.18	2.18	8500
9000																									9000
9500																									9500
10000																									10000
10500																									10500
11000																									11000
11500																									11500
12000																									12000
12500																									12500
13000																									13000
13500																									13500
14000																									14000
14500																									14500
15000																									15000



TABLE 4.2 DOUBLE UNLAPPED

Span	EC/EZ_250-15						EC/EZ_250-19						EC/EZ_250-24						Span
	In	L/ 150	Outward				In	L/ 150	Outward				In	L/ 150	Outward				
			0	1	2	3			0	1	2	3			0	1	2	3	
2500	7.35	84.8	7.35	7.35	7.35	7.35	12.8	111.3	12.8	12.8	12.8	12.8	16.2	145.1	16.2	16.2	16.2	16.2	2500
3000	5.93	49.1	5.93	5.93	5.93	5.93	10.7	64.5	10.7	10.7	10.7	10.7	13.5	83.8	13.5	13.5	13.5	13.5	3000
3500	4.90	30.9	4.90	4.90	4.90	4.90	8.89	40.6	8.89	8.89	8.89	8.89	11.6	52.8	11.6	11.6	11.6	11.6	3500
4000	4.12	20.7	4.12	4.12	4.12	4.12	7.32	27.2	7.32	7.32	7.32	7.32	10.2	35.3	10.2	10.2	10.2	10.2	4000
4500	3.59	14.9	3.59	3.59	3.59	3.59	6.24	19.5	6.24	6.24	6.24	6.24	9.16	25.4	9.2	9.2	9.2	9.2	4500
5000	3.09	10.9	3.09	3.09	3.09	3.09	5.29	14.2	5.29	5.29	5.29	5.29	7.96	18.5	7.96	7.96	7.96	7.96	5000
5500	2.69	8.12	2.69	2.69	2.69	2.69	4.54	10.7	4.54	4.54	4.54	4.54	6.57	13.9	6.57	6.57	6.57	6.57	5500
6000	2.36	6.26	2.36	2.36	2.36	2.36	3.92	8.21	3.90	3.92	3.92	3.92	5.53	10.7	5.34	5.53	5.53	5.53	6000
6500	2.13	5.02	2.13	2.13	2.13	2.13	3.41	6.58	3.21	3.41	3.41	3.41	4.80	8.56	4.40	4.80	4.80	4.80	6500
7000	1.89	4.02	1.89	1.89	1.89	1.89	2.95	5.27	2.63	2.95	2.95	2.95	4.14	6.86	3.59	4.14	4.14	4.14	7000
7500	1.69	3.27	1.57	1.69	1.69	1.69	2.57	4.28	2.16	2.57	2.57	2.57	3.61	5.57	2.90	3.61	3.61	3.61	7500
8000	1.53	2.70	1.31	1.53	1.53	1.53	2.25	3.54	1.78	2.25	2.25	2.25	3.17	4.59	2.33	3.17	3.17	3.17	8000
8500	1.38	2.25	1.07	1.38	1.38	1.38	2.00	2.95	1.46	2.00	2.00	2.00	2.81	3.83	1.88	2.81	2.81	2.81	8500
9000																			9000
9500																			9500
10000																			10000
10500																			10500
11000																			11000
11500																			11500
12000																			12000
12500																			12500
13000																			13000
13500																			13500
14000																			14000
14500																			14500
15000																			15000

Span	EC/EZ_300-19						EC/EZ_300-24						EC/EZ_300-30						Span
	In	L/ 150	Outward				In	L/ 150	Outward				In	L/ 150	Outward				
			0	1	2	3			0	1	2	3			0	1	2	3	
2500																			2500
3000																			3000
3500																			3500
4000	7.22	47.7	7.22	7.22	7.22	7.22	13.2	62.5	13.2	13.2	13.2	13.2	21.4	80.6	21.4	21.4	21.4	21.4	4000
4500	6.32	34.1	6.32	6.32	6.32	6.32	11.2	44.8	11.2	11.2	11.2	11.2	18.1	57.7	18.1	18.1	18.1	18.1	4500
5000	5.48	24.9	5.48	5.48	5.48	5.48	9.60	32.7	9.60	9.60	9.60	9.60	15.1	42.1	15.1	15.1	15.1	15.1	5000
5500	4.81	18.7	4.81	4.81	4.81	4.81	8.27	24.5	8.27	8.27	8.27	8.27	12.8	31.7	12.8	12.8	12.8	12.8	5500
6000	4.25	14.4	4.25	4.25	4.25	4.25	7.21	18.9	7.21	7.21	7.21	7.21	10.7	24.3	10.7	10.7	10.7	10.7	6000
6500	3.84	11.6	3.84	3.84	3.84	3.84	6.44	15.2	6.44	6.44	6.44	6.44	9.26	19.5	9.26	9.3	9.3	9.3	6500
7000	3.45	9.24	3.45	3.45	3.45	3.45	5.67	12.2	5.67	5.67	5.67	5.67	7.98	15.6	7.97	8.0	8.0	8.0	7000
7500	3.10	7.52	3.09	3.09	3.10	3.10	4.94	9.86	4.86	4.94	4.94	4.94	6.96	12.7	6.76	6.96	6.96	6.96	7500
8000	2.79	6.19	2.79	2.79	2.79	2.79	4.33	8.12	4.10	4.33	4.33	4.33	6.12	10.5	5.73	6.12	6.12	6.12	8000
8500	2.53	5.16	2.53	2.53	2.53	2.53	3.84	6.77	3.47	3.84	3.84	3.84	5.41	8.73	4.86	5.41	5.41	5.41	8500
9000																			9000
9500																			9500
10000																			10000
10500																			10500
11000																			11000
11500																			11500
12000																			12000
12500																			12500
13000																			13000
13500																			13500
14000																			14000
14500																			14500
15000																			15000

Where strength matters



TABLE 4.3 LAPPED ONE END



Span	EZ_250-15						EZ_250-19						EZ_250-24						Span
	In	L/150	Outward				In	L/150	Outward				In	L/150	Outward				
			0	1	2	3			0	1	2	3			0	1	2	3	
2500	8.38	96.1	8.7	8.7	8.7	8.7	16.3	126.4	17.0	17.0	17.0	17.0	20.0	164.3	20.8	20.8	20.8	20.8	2500
3000	6.82	55.6	7.10	7.09	7.09	7.09	13.0	72.9	13.5	13.5	13.5	13.5	16.7	94.9	17.3	17.3	17.3	17.3	3000
3500	5.70	35.1	5.92	5.92	5.92	5.92	10.7	76.3	11.1	11.1	11.1	11.1	14.3	59.8	14.9	14.9	14.9	14.9	3500
4000	4.84	23.5	5.03	5.03	5.03	5.03	8.87	30.8	9.22	9.22	9.22	9.22	12.5	40.1	13.0	13.0	13.0	13.0	4000
4500	4.16	16.5	4.33	4.33	4.33	4.33	7.51	21.7	7.80	7.80	7.80	7.80	11.1	28.1	11.5	11.5	11.5	11.5	4500
5000	3.63	12.1	3.77	3.77	3.77	3.77	6.42	15.8	6.68	6.68	6.68	6.68	9.99	20.5	10.4	10.4	10.4	10.4	5000
5500	3.19	9.03	3.32	3.32	3.32	3.32	5.56	11.9	5.77	5.77	5.77	5.77	8.72	15.5	8.67	9.06	9.06	9.06	5500
6000	2.82	6.96	2.93	2.93	2.93	2.93	4.85	9.11	5.03	5.04	5.04	5.04	7.33	11.9	6.87	7.61	7.61	7.61	6000
6500	2.57	5.58	2.62	2.62	2.62	2.62	4.35	7.31	4.03	4.43	4.43	4.43	6.36	9.52	5.45	6.49	6.49	6.49	6500
7000	2.30	4.47	2.34	2.34	2.34	2.34	3.85	5.86	3.25	3.93	3.93	3.93	5.50	7.62	4.29	5.60	5.60	5.60	7000
7500	2.07	3.64	1.95	2.11	2.11	2.11	3.41	4.77	2.61	3.47	3.47	3.47	4.78	6.20	3.37	4.87	4.87	4.87	7500
8000	1.88	3.00	1.55	1.91	1.91	1.91	2.99	3.92	2.08	3.05	3.05	3.05	4.20	5.10	2.65	4.23	4.28	4.28	8000
8500	1.70	2.50	1.26	1.74	1.74	1.74	2.65	3.27	1.66	2.63	2.71	2.71	3.73	4.25	2.12	3.61	3.80	3.80	8500
9000	1.56	2.10	1.04	1.59	1.59	1.59	2.37	2.76	1.34	2.25	2.41	2.41	3.32	3.58	1.72	3.09	3.39	3.39	9000
9500	1.43	1.80	0.85	1.38	1.45	1.45	2.12	2.35	1.10	1.94	2.16	2.16	2.98	3.06	1.42	2.66	3.04	3.04	9500
10000	1.31	1.54	0.71	1.20	1.34	1.34	1.91	2.02	0.91	1.68	1.95	1.95	2.69	2.62	1.19	2.27	2.75	2.75	10000
10500	1.23	1.36	0.59	1.05	1.23	1.23	1.77	1.77	0.76	1.44	1.77	1.77	2.49	2.30	1.00	1.93	2.49	2.49	10500
11000	1.14	1.18		0.92	1.14	1.14	1.61	1.54	0.65	1.26	1.61	1.61	2.27	2.01	0.84	1.64	2.27	2.27	11000
11500	1.04	1.03		0.78	1.03	1.04	1.48	1.35	0.55	1.07	1.48	1.48	2.08	1.75	0.72	1.39	2.04	2.08	11500
12000	0.96	0.91		0.68	0.93	0.96	1.36	1.19		0.91	1.33	1.36	1.91	1.54	0.62	1.19	1.82	1.91	12000
12500	0.89	0.80		0.58	0.83	0.89	1.26	1.06		0.78	1.18	1.26	1.75	1.36	0.53	1.02	1.63	1.75	12500
13000	0.82	0.72			0.76	0.82	1.16	0.94		0.67	1.07	1.16	1.60	1.22		0.88	1.46	1.63	13000
13500	0.75	0.64			0.69	0.76	1.08	0.84		0.58	0.96	1.08	1.46	1.09		0.76	1.31	1.51	13500
14000	0.70	0.57			0.62	0.71	0.98	0.75			0.87	1.00	1.33	0.97		0.67	1.17	1.41	14000
14500	0.63	0.52			0.56	0.64	0.90	0.68			0.78	0.93	1.22	0.88		0.58	1.05	1.29	14500
15000	0.59	0.47				0.59	0.82	0.61			0.70	0.86	1.12	0.80			0.93	1.17	15000

Span	EZ_300-19					EZ_300-24					EZ_300-30					Span				
	In	L/150	Outward			In	L/150	Outward			In	L/150	Outward							
			0	1	2			3	0	1			2	3	0		1	2	3	
2500																				2500
3000																				3000
3500																				3500
4000	8.39	54.0	8.73	8.73	8.73	8.73	15.7	70.8	16.3	16.3	16.3	16.3	23.7	91.3	24.6	24.6	24.6	24.6	4000	
4500	7.27	37.9	7.56	7.56	7.56	7.56	13.4	49.7	1.39	1.39	1.39	1.39	21.0	64.1	21.9	21.9	21.9	21.9	4500	
5000	6.37	27.7	6.62	6.62	6.62	6.62	11.5	36.3	12.0	12.0	12.0	12.0	18.8	46.8	19.5	19.5	19.5	19.5	5000	
5500	5.63	20.8	5.85	5.85	5.85	5.85	10.0	27.3	10.4	10.4	10.4	10.4	16.1	35.1	16.7	16.7	16.7	16.7	5500	
6000	5.01	16.0	5.21	5.21	5.21	5.21	8.78	21.0	9.13	9.12	9.13	9.13	13.9	27.1	14.5	14.5	14.5	14.5	6000	
6500	4.58	12.8	4.67	4.67	4.67	4.67	7.91	16.8	8.06	8.06	8.06	8.06	12.4	21.8	12.4	12.6	12.6	12.6	6500	
7000	4.12	10.3	4.20	4.20	4.20	4.20	7.04	13.5	7.18	7.18	7.18	7.18	10.6	17.4	10.4	10.8	10.8	10.8	7000	
7500	3.73	8.35	3.80	3.80	3.80	3.80	6.29	11.0	6.13	6.41	6.41	6.41	9.23	14.2	8.60	9.41	9.41	9.41	7500	
8000	3.39	6.88	3.46	3.46	3.46	3.46	5.66	9.03	5.11	5.77	5.77	5.77	8.11	11.6	7.12	8.27	8.27	8.27	8000	
8500	3.09	5.74	3.15	3.15	3.15	3.15	5.09	7.53	4.28	5.19	5.19	5.19	7.18	9.70	5.89	7.32	7.32	7.32	8500	
9000	2.83	4.83	2.74	2.89	2.89	2.89	4.54	6.33	3.62	4.63	4.63	4.63	6.41	8.17	4.87	6.53	6.53	6.53	9000	
9500	2.61	4.11	2.29	2.66	2.66	2.66	4.08	5.39	3.06	4.16	4.16	4.16	5.75	6.95	4.02	5.87	5.87	5.87	9500	
10000	2.40	3.52	1.91	2.45	2.45	2.45	3.68	4.63	2.56	3.75	3.75	3.75	5.20	5.96	3.33	5.26	5.30	5.30	10000	
10500	2.26	3.11	1.61	2.26	2.26	2.26	3.41	4.07	2.14	3.35	3.41	3.41	4.80	5.25	2.79	4.67	4.80	4.80	10500	
11000	2.09	2.70	1.37	2.09	2.09	2.09	3.10	3.54	1.80	2.96	3.10	3.10	4.38	4.57	2.34	4.16	4.38	4.38	11000	
11500	1.94	2.36	1.19	1.89	1.94	1.94	2.84	3.10	1.53	2.61	2.84	2.84	4.00	4.00	2.00	3.69	4.00	4.00	11500	
12000	1.81	2.08	1.03	1.7	1.81	1.81	2.60	2.73	1.30	2.32	2.60	2.60	3.67	3.51	1.71	3.27	3.67	3.67	12000	
12500	1.69	1.85	0.88	1.52	1.69	1.69	2.40	2.41	1.12	2.05	2.40	2.40	3.39	3.11	1.48	2.89	3.39	3.39	12500	
13000	1.57	1.64	0.76	1.36	1.57	1.57	2.22	2.15	0.98	1.83	2.22	2.22	3.14	2.77	1.28	2.56	3.14	3.14	13000	
13500	1.46	1.47	0.66	1.23	1.46	1.46	2.06	1.92	0.85	1.63	2.06	2.06	2.90	2.47	1.12	2.25	2.90	2.90	13500	
14000	1.35	1.31	0.57	1.09	1.35	1.35	1.92	1.72	0.74	1.46	1.92	1.92	2.70	2.22	0.99	1.99	2.70	2.70	14000	
14500	1.27	1.18		0.96	1.26	1.27	1.79	1.55	0.66	1.30	1.79	1.79	2.52	2.00	0.87	1.74	2.49	2.52	14500	
15000	1.18	1.07					1.67	1.40	0.59	1.16	1.64	1.67	2.33	1.81	0.77	1.54	2.29	2.36	15000	

Where strength matters



TABLE 4.4 LAPPED BOTH ENDS (CONTINUOUS)

Where strength matters

Span	EZ_I50-12					EZ_I50-15					EZ_I50-19					EZ_I50-24					Span				
	In	L/150	Outward				In	L/150	Outward				In	L/150	Outward				In	L/150		Outward			
			0	1	2	3			0	1	2	3			0	1	2	3				0	1	2	3
2500	7.10	16.5	7.10	7.10	7.10	7.10	11.9	21.1	11.9	11.9	11.9	11.9	18.7	27.1	18.7	18.7	18.7	18.7	22.2	34.5	22.2	22.2	22.2	22.2	2500
3000	5.63	9.55	5.64	5.64	5.63	5.63	9.02	12.3	9.03	9.03	9.02	9.01	13.0	15.8	13.0	13.0	13.0	13.0	17.7	20.0	17.5	17.7	17.7	17.7	3000
3500	4.58	6.02	4.58	4.58	4.58	4.58	6.83	7.68	6.83	6.83	6.83	6.83	9.51	9.88	9.48	9.51	9.51	9.51	13.0	12.6	12.0	13.0	13.0	13.0	3500
4000	3.79	4.03	3.79	3.79	3.79	3.79	5.23	5.15	4.89	5.23	5.23	5.23	7.29	6.62	6.67	7.29	7.29	7.29	9.93	8.41	8.43	9.93	9.93	9.93	4000
4500	3.18	2.83	2.86	3.18	3.18	3.18	4.13	3.61	3.60	4.13	4.13	4.13	5.75	4.65	4.76	5.75	5.75	5.75	7.85	5.90	6.07	7.85	7.85	7.85	4500
5000	2.60	2.06	2.02	2.60	2.60	2.60	3.35	2.63	2.64	3.35	3.35	3.35	4.66	3.39	3.42	4.66	4.66	4.66	6.36	4.31	4.40	6.11	6.36	6.36	5000
5500	2.15	1.56	1.44	2.15	2.15	2.15	2.77	1.99	1.90	2.74	2.77	2.77	3.85	2.55	2.45	3.80	3.85	3.85	5.26	3.24	3.19	4.81	5.26	5.26	5500
6000	1.81	1.20	1.05	1.80	1.81	1.81	2.33	1.53	1.37	2.20	2.33	2.33	3.24	1.96	1.78	3.02	3.24	3.24	4.42	2.49	2.34	3.83	4.42	4.42	6000
6500	1.57	0.96	0.81	1.47	1.57	1.57	2.03	1.23	1.04	1.82	2.03	2.03	2.82	1.58	1.35	2.46	2.82	2.82	3.83	2.01	1.79	3.13	3.82	3.83	6500
7000	1.35	0.78	0.61	1.17	1.35	1.35	1.75	0.98	0.79	1.49	1.75	1.75	2.42	1.27	1.04	1.97	2.42	2.42	3.31	1.60	1.39	2.53	3.19	3.31	7000
7500	1.18	0.63		0.92	1.18	1.18	1.52	0.80	0.61	1.21	1.52	1.52	2.11	1.03	0.81	1.58	2.11	2.11	2.88	1.31	1.09	2.05	2.79	2.88	7500
8000	1.04	0.52		0.73	1.04	1.04	1.33	0.66		0.96	1.30	1.33	1.86	0.85	0.65	1.26	1.80	1.86	2.53	1.08	0.87	1.66	2.29	2.53	8000
8500	0.92	0.44		0.58	0.92	0.92	1.19	0.55		0.77	1.12	1.19	1.65	0.71		1.01	1.54	1.65	2.24	0.90	0.72	1.34	1.96	2.21	8500
9000	0.82	0.37			0.78	0.82	1.06	0.47		0.61	0.96	1.06	1.47	0.59		0.81	1.31	1.47	2.00	0.76	0.59	1.08	1.67	1.92	9000
9500	0.74	0.31			0.66	0.74	0.95	0.40		0.84	0.95	1.32	1.51			0.66	1.12	1.32	1.77	0.64		0.89	1.43	1.69	9500
10000	0.66	0.27			0.56	0.66	0.86	0.35		0.73	0.85	1.19	1.44			0.54	0.96	1.17	1.57	0.55		0.74	1.23	1.48	10000
10500	0.61	0.24			0.61	0.79	0.30			0.64	0.76	1.10	1.38			0.83	1.05	1.44	0.49			0.63	1.08	1.33	10500
11000					0.55	0.72	0.27			0.54	0.68	1.01	1.33			0.71	0.92	1.29	0.43			0.53	0.93	1.17	11000
11500					0.67	0.23				0.60	0.92	0.29				0.61	0.82	1.16	0.37			0.79	1.04	1.1500	
12000										0.54	0.84	0.26				0.72	1.05	0.33				0.69	0.92	12000	
12500																									12500
13000																									13000
13500																									13500
14000																									14000
14500																									14500
15000																									15000

Span	EZ_200-12					EZ_200-15					EZ_200-19					EZ_200-24					Span				
	In	L/150	Outward				In	L/150	Outward				In	L/150	Outward				In	L/150		Outward			
			0	1	2	3			0	1	2	3			0	1	2	3				0	1	2	3
2500	5.76	34.8	5.76	5.76	5.76	5.76	10.8	45.2	10.8	10.8	10.8	10.8	20.3	59.8	20.3	20.3	20.3	20.3	22.1	75.9	22.1	22.1	22.1	22.1	2500
3000	4.71	20.2	4.72	4.72	4.71	4.71	8.61	26.1	8.63	8.62	8.62	8.62	15.9	34.6	15.9	15.9	15.9	15.9	18.5	44.0	18.5	18.5	18.5	18.5	3000
3500	3.96	12.7	3.96	3.96	3.96	3.96	7.10	16.5	7.10	7.10	7.10	7.10	12.9	21.8	12.9	12.9	12.9	12.9	15.9	27.6	15.9	15.9	15.9	15.9	3500
4000	3.39	8.49	3.39	3.39	3.39	3.39	5.96	11.1	5.96	5.96	5.96	5.96	10.5	14.6	10.5	10.5	10.5	10.5	13.8	18.6	13.8	13.8	13.8	13.8	4000
4500	2.93	5.96	2.93	2.93	2.93	2.93	5.06	7.74	5.06	5.06	5.06	5.06	8.75	10.3	8.42	8.75	8.75	8.75	12.0	13.0	11.4	12.0	12.0	12.0	4500
5000	2.58	4.34	2.58	2.58	2.58	2.58	4.37	5.64	4.37	4.36	4.37	4.36	7.10	7.48	6.42	7.10	7.10	7.10	9.75	9.48	8.53	9.75	9.75	9.75	5000
5500	2.27	3.27	2.27	2.27	2.27	2.27	3.79	4.24	3.48	3.79	3.79	3.79	5.86	5.62	4.99	5.86	5.86	5.86	8.06	7.12	6.41	8.06	8.06	8.06	5500
6000	2.03	2.51	2.03	2.03	2.03	2.03	3.32	3.17	2.63	3.32	3.32	3.32	4.94	4.33	3.82	4.94	4.94	4.94	6.77	5.49	4.82	6.77	6.77	6.77	6000
6500	1.85	2.03	1.59	1.85	1.85	1.85	2.94	2.62	2.03	2.94	2.94	2.94	4.29	3.47	2.90	4.26	4.29	4.29	5.88	4.41	3.68	5.88	5.88	5.88	6500
7000	1.67	1.62	1.23	1.67	1.67	1.67	2.54	2.10	1.59	2.54	2.54	2.54	3.70	2.78	2.19	3.53	3.70	3.70	5.08	3.53	2.79	4.80	5.08	5.08	7000
7500	1.51	1.32	0.96	1.51	1.51	1.51	2.21	1.71	1.25	2.11	2.21	2.21	3.22	2.27	1.70	2.95	3.22	3.22	4.42	2.87	2.16	3.97	4.42	4.42	7500
8000	1.37	1.08	0.76	1.31	1.37	1.37	1.95	1.41	0.98	1.75	1.95	1.95	2.84	1.86	1.33	2.49	2.84	2.84	3.89	2.37	1.71	3.28	3.89	3.89	8000
8500	1.26	0.91	0.61	1.10	1.26	1.26	1.72	1.17	0.78	1.45	1.72	1.72	2.50	1.56	1.06	2.11	2.50	2.50	3.45	1.98	1.37	2.73	3.45	3.45	8500
9000	1.15	0.76		0.93	1.15	1.15	1.54	0.99	0.63	1.20	1.54	1.54	2.23	1.31	0.87	1.77	2.23	2.23	3.08	1.66	1.11	2.25	3.08	3.08	9000
9500	1.06	0.65		0.77	1.04	1.06	1.38	0.84		1.00	1.38	1.38	2.01	1.11	0.71	1.46	1.96	2.01	2.76	1.41	0.92	1.86	2.69	2.76	9500
10000	0.96	0.55		0.65	0.92	0.96	1.25	0.73		0.83	1.25	1.25	1.82	0.96	0.59	1.19	1.73	1.82	2.49	1.22	0.76	1.54	2.35	2.49	10000
10500	0.89	0.49		0.55	0.82	0.89	1.15	0.64		0.72	1.11	1.15	1.68	0.84		1.01	1.55	1.68	2.30	1.07	0.66	1.30	2.09	2.30	10500
11000	0.81	0.43		0.72	0.81	1.05	0.55			0.62	0.97	1.05	1.53	0.73		0.84	1.37	1.53	2.10	0.93	0.56	1.09	1.83	2.10	11000
11500	0.74	0.37		0.64	0.74	0.96	0.49			0.85	0.96	1.40	1.40	0.64		0.71	1.22	1.40	1.92	0.81		0.93	1.60	1.92	11500
12000	0.68	0.33		0.56	0.67	0.88	0.43			0.74	0.88	1.28	0.57			0.61	1.08	1.26	1.76	0.72		0.79	1.40	1.73	12000
12500						0.82	0.38			0.65	0.82	1.19	0.50			0.96	1.14	1.63	0.63			0.68	1.23	1.55	12500
13000						0.75	0.34			0.57	0.74	1.09	0.45			0.84	1.03	1.49	0.57			0.58	1.07	1.40	13000
13500						0.70	0.30			0.67	1.02	0.40				0.72	0.94	1.37	0.51			0.94	1.25	1.3500	
14000						0.65	0.27			0.61	0.94	0.36				0.63	0.85	1.25	0.46			0.81	1.13	14000	
14500						0.61	0.25			0.54	0.86	0.32				0.55	0.78	1.15	0.41			0.72	1.02	14500	
15000													0.79	0.29								0.62	0.92	15000	



TABLE 4.4 LAPPED BOTH ENDS (CONTINUOUS)

Span	EZ_250-15						EZ_250-19						EZ_250-24						Span	
	In	L/150	Outward				In	L/150	Outward				In	L/150	Outward					
			0	1	2	3			0	1	2	3			0	1	2	3		
2500	8.89	75.6	8.89	8.89	8.89	8.89	17.5	99.2	17.5	17.5	17.5	17.5	22.3	128.8	22.3	22.3	22.3	22.3	22.3	2500
3000	7.29	43.8	7.31	7.31	7.29	7.29	14.3	57.5	14.3	14.3	14.2	14.2	18.6	74.7	18.6	18.6	18.6	18.6	18.6	3000
3500	6.14	27.6	6.14	6.14	6.14	6.14	11.8	36.1	11.8	11.8	11.8	11.8	16.0	47.1	16.0	16.0	16.0	16.0	16.0	3500
4000	5.27	18.5	5.27	5.27	5.27	5.27	9.95	24.2	9.95	9.95	9.95	9.95	13.9	31.6	13.9	13.9	13.9	13.9	13.9	4000
4500	4.58	13.1	4.58	4.58	4.58	4.58	8.52	17.0	8.52	8.52	8.52	8.52	12.4	22.2	12.4	12.4	12.4	12.4	12.4	4500
5000	4.02	9.46	4.02	4.02	4.02	4.02	7.38	12.5	7.38	7.38	7.38	7.38	11.2	16.2	11.2	11.2	11.2	11.2	11.2	5000
5500	3.57	7.11	3.57	3.57	3.57	3.57	6.45	9.32	6.40	6.45	6.45	6.45	10.2	12.1	8.65	10.2	10.2	10.2	10.2	5500
6000	3.19	5.47	3.19	3.18	3.19	3.19	5.68	7.18	4.93	5.68	5.68	5.68	8.74	9.33	6.44	8.74	8.74	8.74	8.74	6000
6500	2.93	4.39	2.83	2.93	2.93	2.93	5.14	5.76	3.81	5.14	5.14	5.14	7.58	7.49	4.88	7.58	7.58	7.58	7.58	6500
7000	2.64	3.51	2.18	2.64	2.64	2.64	4.58	4.61	2.87	4.58	4.58	4.58	6.55	6.00	3.69	6.35	6.55	6.55	6.55	7000
7500	2.39	2.87	1.73	2.39	2.39	2.39	4.06	3.75	2.21	3.84	4.06	4.06	5.70	4.88	2.84	5.28	5.70	5.70	5.70	7500
8000	2.19	2.36	1.35	2.19	2.19	2.19	3.56	3.09	1.74	3.21	3.56	3.56	5.01	4.02	2.24	4.40	5.01	5.01	5.01	8000
8500	2.00	1.97	1.08	1.94	2.00	2.00	3.16	2.58	1.38	2.70	3.16	3.16	4.44	3.36	1.78	3.66	4.44	4.44	4.44	8500
9000	1.84	1.66	0.87	1.65	1.84	1.84	2.82	2.17	1.12	2.26	2.82	2.82	3.97	2.83	1.44	3.00	3.97	3.97	3.97	9000
9500	1.69	1.41	0.70	1.38	1.69	1.69	2.53	1.85	0.91	1.89	2.53	2.53	3.55	2.40	1.18	2.46	3.54	3.55	3.55	9500
10000	1.56	1.21	0.58	1.16	1.56	1.56	2.28	1.58	0.75	1.56	2.26	2.28	3.21	2.06	0.99	2.02	3.10	3.21	3.21	10000
10500	1.47	1.06		0.99	1.42	1.47	2.11	1.39	0.64	1.32	2.01	2.11	2.97	1.82	0.84	1.70	2.77	2.97	2.97	10500
11000	1.36	0.93		0.84	1.25	1.36	1.93	1.21	0.54	1.10	1.77	1.93	2.70	1.58	0.71	1.43	2.44	2.70	2.70	11000
11500	1.24	0.81		0.72	1.12	1.24	1.76	1.07		0.93	1.56	1.76	2.47	1.39	0.61	1.21	2.14	2.47	2.47	11500
12000	1.14	0.72		0.61	0.99	1.14	1.62	0.94		0.78	1.38	1.61	2.27	1.22		1.03	1.87	2.27	2.27	12000
12500	1.05	0.63		0.89	1.03	1.49	1.49	0.84		0.67	1.22	1.49	2.09	1.08		0.88	1.63	2.05	2.05	12500
13000	0.97	0.56		0.79	0.94	1.38	1.38	0.74		0.58	1.08	1.34	1.93	0.96		0.75	1.42	1.85	1.85	13000
13500	0.91	0.51		0.70	0.85	1.28	1.28	0.66		0.95	1.21	1.79	1.79	0.86		0.66	1.23	1.67	1.67	13500
14000	0.84	0.46		0.61	0.78	1.19	1.19	0.59		0.82	1.10	1.64	1.64	0.76		0.57	1.07	1.50	1.50	14000
14500	0.78	0.40		0.54	0.71	1.11	1.11	0.53		0.72	0.99	1.50	1.50	0.69		0.93	1.36	1.4500	1.4500	14500
15000	0.72	0.37			0.64	1.02	1.02	0.48		0.64	0.90	1.39	1.39	0.63		0.82	1.23	15000	15000	15000

Span	EZ_300-19						EZ_300-24						EZ_300-30						Span		
	In	L/150	Outward				In	L/150	Outward				In	L/150	Outward						
			0	1	2	3			0	1	2	3			0	1	2	3			
2500																					2500
3000																					3000
3500																					3500
4000	9.07	42.6	9.07	9.07	9.07	9.07	17.3	55.7	17.3	17.3	17.3	17.3	30.5	71.8	30.5	30.5	30.5	30.5	30.5	4000	
4500	7.92	29.9	7.92	7.92	7.92	7.92	15.0	39.2	15.0	15.0	15.0	15.0	23.4	50.4	23.4	23.4	23.4	23.4	23.4	4500	
5000	6.99	21.8	7.00	6.99	6.99	6.99	13.1	28.6	13.1	13.1	13.1	13.1	21.0	36.9	21.0	21.0	21.0	21.0	21.0	5000	
5500	6.23	16.3	6.23	6.23	6.23	6.23	11.4	21.5	11.4	11.4	11.4	11.4	19.1	27.6	19.1	19.1	19.1	19.1	19.1	5500	
6000	5.59	12.6	5.59	5.58	5.59	5.59	10.2	16.5	10.2	10.2	10.2	10.2	16.7	21.3	16.7	16.7	16.7	16.7	16.7	6000	
6500	5.14	10.1	5.14	5.14	5.14	5.14	9.22	13.3	9.22	9.22	9.22	9.22	14.7	17.1	13.3	14.7	14.7	14.7	14.7	6500	
7000	4.67	8.09	4.67	4.67	4.67	4.67	8.26	10.6	7.55	8.26	8.26	8.26	12.7	13.7	10.6	12.7	12.7	12.7	12.7	7000	
7500	4.26	6.58	4.26	4.26	4.26	4.26	7.44	8.62	6.15	7.44	7.44	7.44	11.0	11.1	8.36	11.0	11.0	11.0	11.0	7500	
8000	3.90	5.42	3.73	3.90	3.90	3.90	6.74	7.10	5.01	6.74	6.74	6.74	9.67	9.16	6.62	9.67	9.67	9.67	9.67	8000	
8500	3.58	4.51	3.01	3.58	3.58	3.58	6.07	5.92	4.02	6.07	6.07	6.07	8.57	7.64	5.26	8.54	8.57	8.57	8.57	8500	
9000	3.30	3.80	2.46	3.30	3.30	3.30	5.41	4.99	3.24	5.31	5.41	5.41	7.64	6.44	4.23	7.43	7.65	7.64	7.64	9000	
9500	3.04	3.24	2.05	3.04	3.04	3.04	4.86	4.24	2.64	4.58	4.86	4.86	6.86	5.47	3.46	6.46	6.86	6.86	6.86	9500	
10000	2.82	2.78	1.70	2.82	2.82	2.82	4.39	3.64	2.17	3.97	4.39	4.39	6.19	4.69	2.85	5.62	6.19	6.19	6.19	10000	
10500	2.67	2.45	1.44	2.58	2.67	2.67	4.06	3.20	1.84	3.50	4.06	4.06	5.72	4.14	2.42	4.94	5.72	5.72	5.72	10500	
11000	2.49	2.13	1.20	2.27	2.49	2.49	3.70	2.79	1.55	3.06	3.70	3.70	5.21	3.60	2.04	4.26	5.21	5.21	5.21	11000	
11500	2.32	1.87	1.01	2.00	2.32	2.32	3.38	2.44	1.30	2.67	3.38	3.38	4.77	3.15	1.73	3.66	4.77	4.77	4.77	11500	
12000	2.17	1.64	0.87	1.73	2.17	2.17	3.11	2.15	1.11	2.33	3.11	3.11	4.38	2.77	1.48	3.15	4.38	4.38	4.38	12000	
12500	2.02	1.46	0.74	1.49	2.00	2.02	2.87	1.91	0.96	2.02	2.85	2.87	4.04	2.45	1.28	2.70	3.97	4.04	4.04	12500	
13000	1.88	1.29	0.65	1.30	1.82	1.88	2.64	1.69	0.83	1.75	2.56	2.64	3.74	2.18	1.10	2.32	3.60	3.74	3.74	13000	
13500	1.74	1.15	0.56	1.13	1.66	1.74	2.45	1.52	0.72	1.50	2.32	2.45	3.46	1.94	0.96	2.01	3.26	3.46	3.46	13500	
14000	1.61	1.04		0.99	1.51	1.61	2.29	1.36	0.63	1.31	2.09	2.29	3.22	1.74	0.85	1.74	2.96	3.22	3.22	14000	
14500	1.51	0.93		0.88	1.37	1.51	2.13	1.22	0.55	1.15	1.88	2.13	2.99	1.58	0.74	1.52	2.67	3.00	3.00	14500	
15000	1.40	0.85		0.77	1.26	1.40	1.99	1.10		1.01	1.71	1.9	2.77	1.42	0.66	1.34	2.41	2.81	2.81	15000	

Where strength matters





HOOKFAS[®] BRIDGING SYSTEM



Millform recently developed the **Hookfast[®]** bridging system to gain better control over key processes. We carry out all aspects of manufacturing, quality control, and delivery. This offers a range of benefits, with the lead time for bridging systems greatly reduced, the strength improved, and the packaging enhanced.

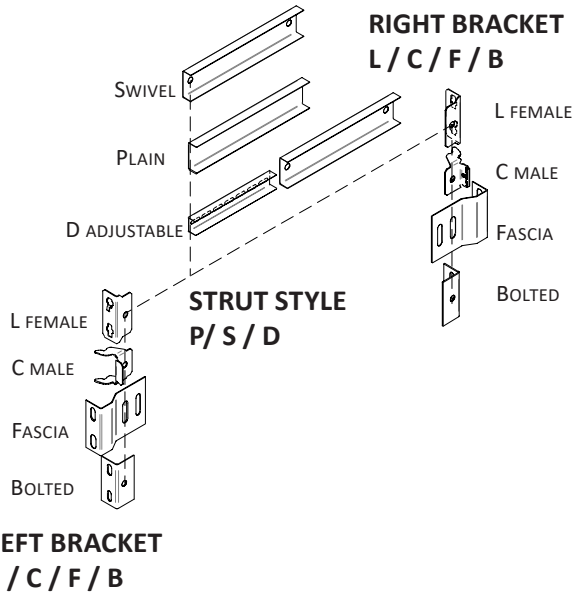

We spent considerable time researching and selecting the best riveting system available. We utilise the Henrob[™] riveting system for a reliable and robust bridging solution. Henrob[™] is owned and operated by a large and talented company dedicated to self-pierce riveting technology. This technology combines reliable design principles with robust production techniques.

Hookfast[®] bridging solutions offer a fast and simple installation process. Bridging is available in adjustable or fixed lengths, including Bolted Bracket and Fascia Clip designs with male or female Hookfast ends. We supply products in 40 mm, 60 mm, 70 mm, 110 mm, 160 mm, and 210 mm widths to suit purlins ranging from 100 mm to 300 mm in width. We also offer the standard speedy spacer system, which includes brackets and 12 mm diameter sag rods with threaded ends.

BRIDGING CODING MILLFORM OCT 18

This document explains how the codes are interpreted for Hook lock bridging.

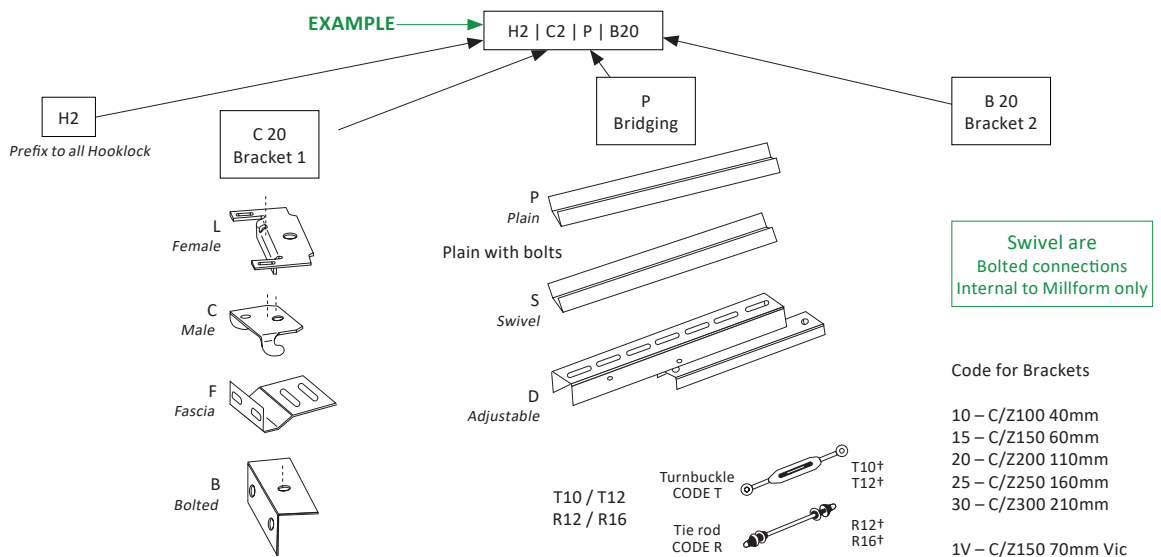

The Information contained in this document is proprietary to Millform Products and may not be copied, reproduced or disseminated in any form by any electronic or mechanical means without the express written permission Millform Products Management.

FIND OUT MORE ABOUT OUR RANGE
OF STEEL BUILDING PRODUCTS

M **MILLFORM**
AUSTRALIA



TOPHAT & BATTENS



PURLIN & CHANNEL



HOOKFAST PURLIN BRIDGING SYSTEM

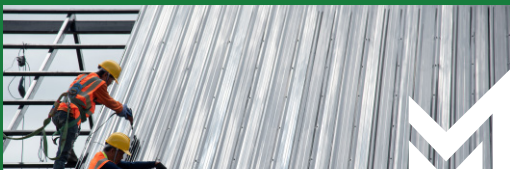

ROOFING & WALLING



ROOFING ACCESSORIES



JUNCTION STUD & FACADE SYSTEM



SLAB & SPIRAL DUCT

MILLFORM OFFICE & MANUFACTURING FACILITY

Sydney

22 Shale Place, Eastern Creek, NSW, 2766
Ph. (02) 9832 6900

Albury

101 Ceres Drive, Albury, NSW, 2640
Ph. (02) 6025 4377

REGIONAL SALES TEAMS

QLD, NSW, ACT, VIC, TAS, WA, NT

**FOR SALES AND INFORMATION ENQUIRIES, CONTACT OUR
KNOWLEDGEABLE TEAM**

Call: **1300 645 376** or email: enquiries@millform.com.au

www.millform.com.au

Version 2.4

All reasonable care has been taken to present accurate information at the time of publication. All recommendations related to the use of Millform products are made without a guarantee. Many factors are beyond our control, and all information presented is meant as a guide only. It is the customer's responsibility to ensure that all products are suitable for their intended purpose. Millform reserves the right to change product specifications and recommendations at any time without prior notice. The Millform logo is registered and protected under Australian law.

