



MILLFORM
AUSTRALIA

Where strength matters



ARCHETYPE
PURLIN™

MILLFORM PURLIN GUIDE & CAPACITY TABLES

C & Z STANDARD PURLINS

CONTENTS

PAGE

GENERAL INFORMATION 4

• Application	4
• Construction Material	4
• Installation Process	4
• Sheet Length & Expansion Joint Sizing	4
• Welding	4
• Safe Work Practice	4
• Material Protection & Compatibility	4
• On-site Storage	4

PRODUCT RANGE & PROPERTIES 5

USING THE MANUAL 15

DESIGN & SPECIFICATION 16

• Hole Punching	16
• Structural Lap Lengths	16
• Member Weight	17
• Deflection	17
• Cleat Connections	17
• Bolts	18
• Point Loads	19

HOW TO USE THE TABLES 20

HOOFAST BRIDGING SYSTEM 21



**MILLFORM
AUSTRALIA**

Where strength matters



With the strength of steel, Millform is dedicated to building a better Australia. We provide quality products, ensure efficient delivery standards, and offer proven solutions for commercial, construction, industrial, and government clients.

You can find other Millform items on our website.

www.millform.com.au

ARCHETYPE
PURLIN™



GENERAL INFORMATION

Application

At Millform, we supply purlins and girts to support roof and wall sheeting. Our products are used in a variety of industrial, commercial, construction, and civil applications.

Construction Materials

Our **Archetype Purlin™** and girts are manufactured from high-quality galvanised steel. We use G450, G500, and G550 products with a minimum Z350 coating. All materials conform to AS 1397.

Installation Process

We have access to an expansive shipping network, with all materials delivered quickly and safely to avoid project delays. We can deliver to most addresses across Australia.

Sheeting and Expansion Joint Sizing

We adapt roof sheeting sizes based on thermal expansion, transportation, and handling requirements. Recommended roof sheeting lengths may vary between projects and state locations.

MAXIMUM ROOF SHEET LENGTH

ROOF COLOUR	THROUGH FIX	CONCEALED FIX
Light	25m	33m
Dark	17m	25 m

Where buildings are designed with roofing runs greater than the table above, expansion joints are necessary.

TYPICAL EXPANSION JOINT

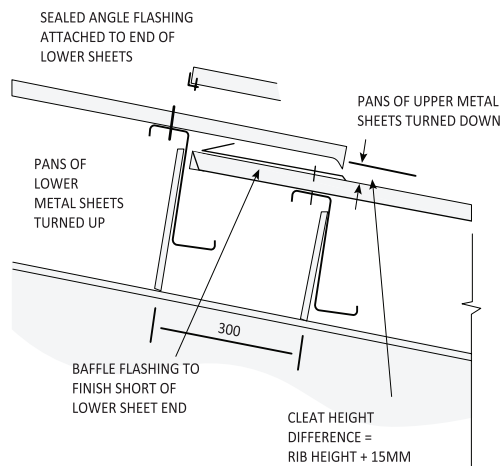

Welding Not Required

Welding is not recommended for purlins, girts, or bridging materials. Cold rolled steel is a high-tensile material, with welding likely to remove the galvanised coating and reduce the lifespan of the product.

Safe Work Practices

Millform strives for the highest levels of safe work practice both internally in our production process and externally in the delivery and handling of our products. Be aware that when material gets wet or moist it can lead to a hazardous situation. We strongly recommend not to walk on steel in these conditions and take extreme care when moving or lifting steel as it can slip off forklifts or cranes. Take time to perform a risk assessment and use the correct equipment.

Material Protection and Compatibility

Some building materials and environmental conditions function poorly with coated steel products. It's important to avoid run-off exposure or contact that results from aggressive atmospheric conditions, incompatible materials, excessive moisture, and treated materials. Incompatible metals include lead and copper, excessive moisture is likely with non-seasoned timber, and treated materials include CcA and tanalith.

When installed correctly in the right locations, standard Z350 galvanised coating will provide a long and maintenance-free life. Typical applications include enclosed buildings and open-sided rural applications in standard environments. While Z450 is available for extreme corrosive settings, this product is subject to extended lead times and minimum order amounts.

On-site Storage

Safe above-ground storage is critical for Z and C sections or bundles. If extended storage is needed, it's important to store materials with a small incline to avoid water from pooling. Materials and equipment should be protected with waterproof covers and never left exposed to the elements for a long period of time.

PRODUCT RANGE & PROPERTIES

Archetype Purlin™ C & Z Sections and Other Shapes

C and Z sections are readily available, and other shapes are available subject to extended lead times and minimum order requirements. Purlins and girts are available in the following sizes:

C SECTIONS

STANDARD C



NESTABLE C
Box Configuration



Z SECTIONS

STANDARD Z

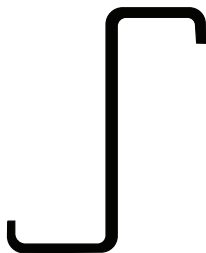

Where strength matters



C – Section Archetype Purlin

C75 Purlin

PURLIN - C75 X 0.75 BMT: **C750.75** (1.02kg/m)

PURLIN - C75 X 0.95 BMT: **C750.95** (1.28kg/m)

PURLIN - C75 X 1.20 BMT: **C7512** (1.61kg/m)

PURLIN - C75 X 1.50 BMT: **C7515** (2.00kg/m)

Standard Pack: 50 Lengths

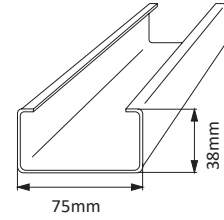

C100 Purlin

PURLIN - C100 X 1.00 BMT: **C10010** (1.64kg/m)

PURLIN - C100 X 1.20 BMT: **C10012** (2.06kg/m)

PURLIN - C100 X 1.50 BMT: **C10015** (2.57kg/m)

PURLIN - C100 X 1.90 BMT: **C10019** (3.24kg/m)

Standard Pack: 50 Lengths

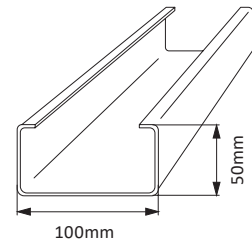

C150 Purlin

PURLIN - C150 X 1.20 BMT: **C15012** (2.83kg/m)

PURLIN - C150 X 1.50 BMT: **C15015** (3.52kg/m)

PURLIN - C150 X 1.90 BMT: **C15019** (4.45kg/m)

PURLIN - C150 X 2.40 BMT: **C15024** (5.60kg/m)

Standard Pack: 50 Lengths

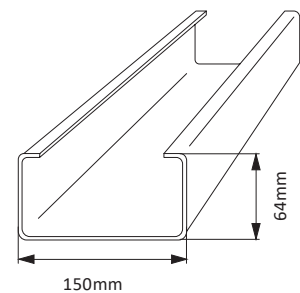

C – Section Archetype Purlin

C200 Purlin

PURLIN - C200 X 1.20 BMT: **C20012** (3.59kg/m)

PURLIN - C200 X 1.50 BMT: **C20015** (4.47kg/m)

PURLIN - C200 X 1.90 BMT: **C20019** (5.65kg/m)

PURLIN - C200 X 2.40 BMT: **C20024** (7.12kg/m)

Standard Pack: 50 Lengths

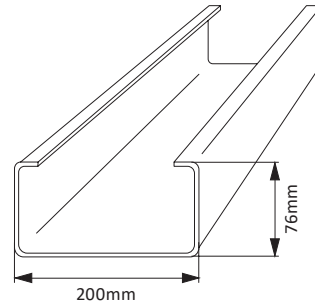

C250 Purlin

PURLIN - C250 X 1.50 BMT: **C25015** (5.07kg/m)

PURLIN - C250 X 1.90 BMT: **C25019** (6.41kg/m)

PURLIN - C250 X 2.40 BMT: **C25024** (8.07kg/m)

Standard Pack: 40 Lengths

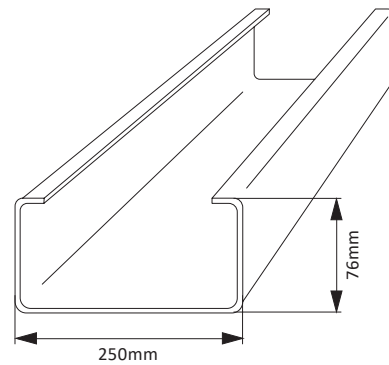

C300 Purlin

PURLIN - C300 X 1.90 BMT: **C30019** (7.91kg/m)

PURLIN - C300 X 2.40 BMT: **C30024** (9.97kg/m)

PURLIN - C300 X 3.00 BMT: **C30030** (12.51kg/m)

Standard Pack: 24 Lengths

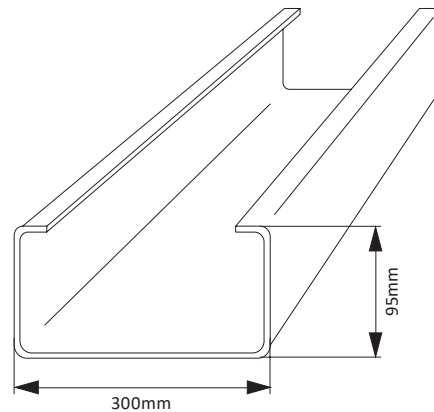

Where strength matters



NOTE: C & Z Purlins are only manufactured down to 2m lengths, shorter lengths will need to be cut by the purchaser.
C Purlins - Part cut any length under 2m **Z Purlin** - Any length under 2m is joined together with no part cut.



Z – Section Archetype Purlin

Z100 Purlin

Z PURLIN - 100 X 1.20 BMT: **Z10012** (2.06kg/m)

Z PURLIN - 100 X 1.50 BMT: **Z10015** (2.57kg/m)

Z PURLIN - 100 X 1.90 BMT: **Z10019** (3.24kg/m)

Standard Pack: 40 Lengths

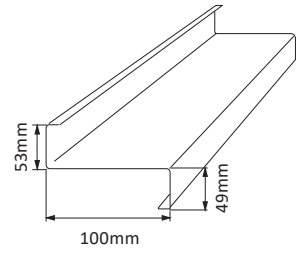

Z150 Purlin

Z PURLIN - 150 X 1.20 BMT: **Z15012** (2.83kg/m)

Z PURLIN - 150 X 1.50 BMT: **Z15015** (3.52kg/m)

Z PURLIN - 150 X 1.90 BMT: **Z15019** (4.45kg/m)

Z PURLIN - 150 X 2.40 BMT: **Z15024** (5.60kg/m)

Standard Pack: 20 Lengths

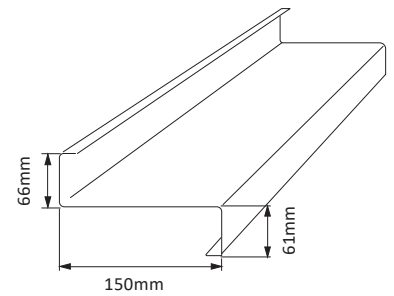

Z200 Purlin

Z PURLIN - 200 X 1.20 BMT: **Z20012** (3.59kg/m)

Z PURLIN - 200 X 1.50 BMT: **Z20015** (4.47kg/m)

Z PURLIN - 200 X 1.90 BMT: **Z20019** (5.65kg/m)

Z PURLIN - 200 X 2.40 BMT: **Z20024** (7.12kg/m)

Standard Pack: 20 Lengths

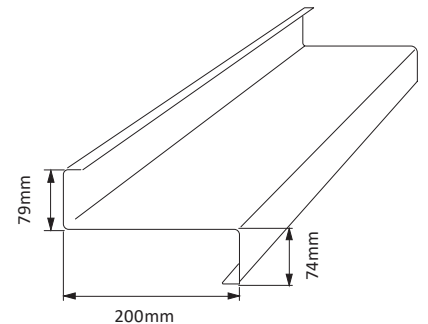

Z – Section Archetype Purlin

Z250 Purlin

Z PURLIN - 250 X 1.50 BMT: **Z25015** (5.07kg/m)

Z PURLIN - 250 X 1.90 BMT: **Z25019** (6.41kg/m)

Z PURLIN - 250 X 2.40 BMT: **Z25024** (8.07kg/m)

Standard Pack: 20 Lengths

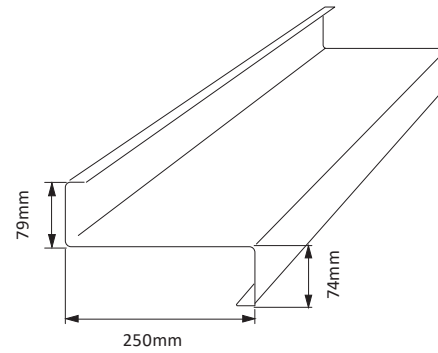

Z300 Purlin

Z PURLIN - 300 X 1.90 BMT: **Z30019** (7.91kg/m)

Z PURLIN - 300 X 2.40 BMT: **Z30024** (9.97kg/m)

Z PURLIN - 300 X 3.00 BMT: **Z30030** (12.51kg/m)

Standard Pack: 20 Lengths

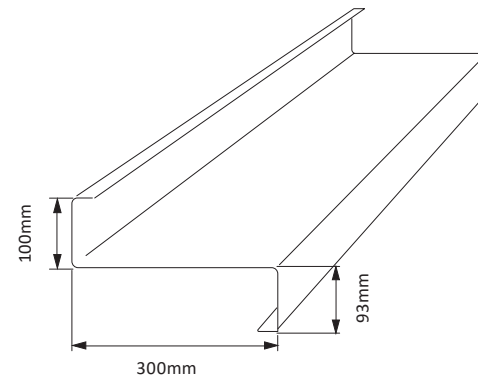

Where strength matters



NOTE: C & Z Purlins are only manufactured down to 2m lengths, shorter lengths will need to be cut by the purchaser.
C Purlins - Part cut any length under 2m **Z Purlin** - Any length under 2m is joined together with no part cut.



Brackets

Angle Connector Bracket

ANGLE CONNECTOR - C100: **MF-AC100** (0.19kg/ea.)

ANGLE CONNECTOR - C150: **MF-AC150** (0.30kg/ea.)

ANGLE CONNECTOR - C200: **MF-AC200** (0.39kg/ea.)

ANGLE CONNECTOR - C250: **MF-AC250** (0.56kg/ea.)

ANGLE CONNECTOR - C300: **MF-AC300** (0.69kg/ea.)

Standard Pack: 50 Brackets

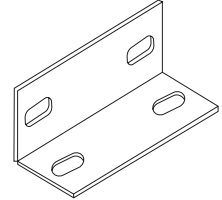

Angle Connector Bracket

General Purpose Bracket

GENERAL PURPOSE BRACKET C100: **GPB100** (0.23kg/ea.)

GENERAL PURPOSE BRACKET C150: **GPB150** (0.41kg/ea.)

GENERAL PURPOSE BRACKET C200: **GPB200** (0.61kg/ea.)

GENERAL PURPOSE BRACKET C250: **GPB250** (0.80kg/ea.)

GENERAL PURPOSE BRACKET C300: **GPB300** (1.00kg/ea.)

Standard Pack: 50 Brackets

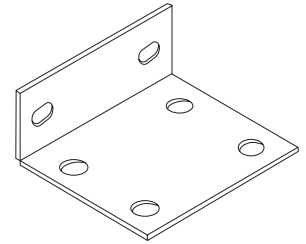

General Purpose Bracket

HookFast Purlin Bridging

Millform *HookFast*[™] Bridging System

(available to suit C/Z100, 150, 200 & 250)

Adj Starter – Adjustable Female / Fascia Cleat

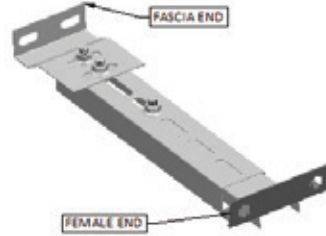

Starter – Bolted / Female

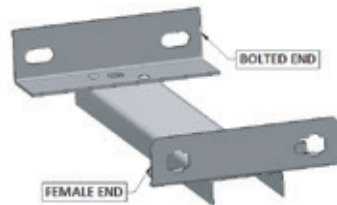

Intermediate – Male / Female

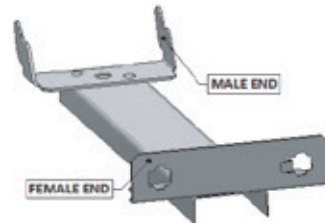

Finisher – Male / Bolted

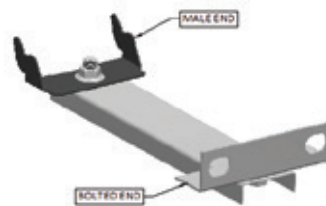

12 mm Sag Rod Ridge Tie (add 100 mm to centres)



Where strength matters





DIMENSIONS & PROPERTIES

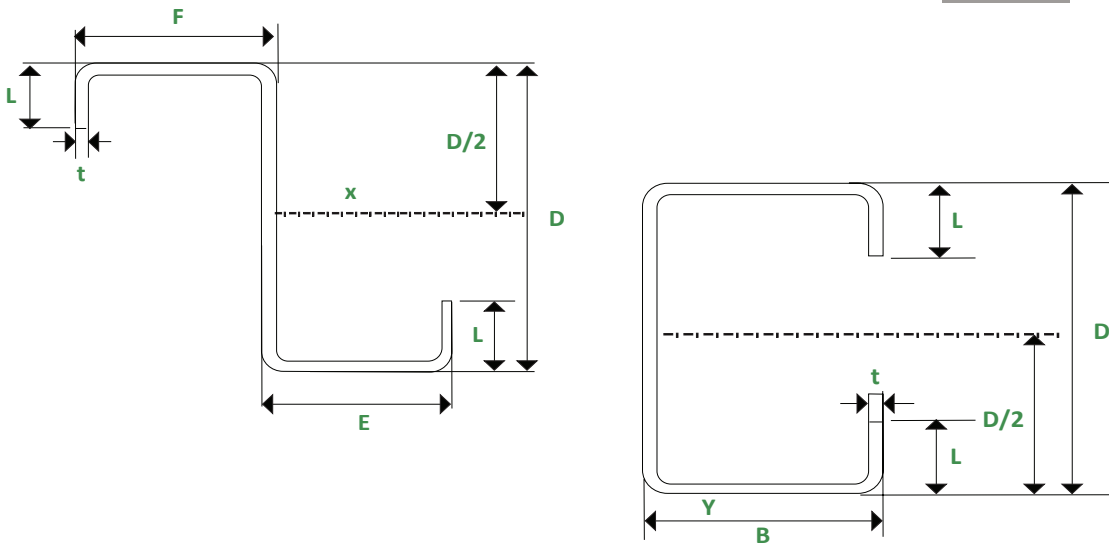

C & Z ARCHETYPE PURLIN SIZE & MASS TABLE

Section	Thickness (t) mm	Height (D) mm	Z PURLINS			C PURLINS		Mass kg/m
			E	F	L	B	L	
100 10*	1.0	102	53	49	12.5	51	12.5	1.75
100 12	1.2	102	53	49	13	51	12.5	2.09
100 15	1.5	102	53	49	13.5	51	13.5	2.59
100 19	1.9	102	53	48	14.5	51	14.5	3.26
150 12	1.2	152	65	61	15.5	64	14.5	2.86
150 15	1.5	152	65	61	16.5	64	15.5	3.55
150 19	1.9	152	65	61	17.5	64	16.5	4.48
150 24	2.4	152	66	60	19.5	64	18.5	5.81
200 15	1.5	203	79	74	18	76	15.5	4.46
200 19	1.9	203	79	74	18.5	76	19	5.69
200 24	2.4	203	79	73	21.5	76	21	7.39
250 19	1.9	254	79	74	18	76	18.5	6.45
250 24	2.4	254	79	73	21	76	20.5	8.37
300 24	2.4	300	100	93	27	96	27.5	10.11
300 30	3.0	300	100	93	31	96	31.5	12.66
350 24*	2.4	350	129	121	30	125	30	12.23
350 30*	3.0	350	129	121	30	125	30	15.15
200 24*	2.4	400	96	96	30	96	30	12.23
400 30*	3.0	400	96	96	30	96	30	15.15

*Minimum order quantity and longer lead times may apply

Please contact Millform for more information.

Material Tolerances

All steel sections are produced with the following tolerances:

- Length ± 5 mm
- Flange width ± 1 mm
- Depth ± 1 mm
- Hole centre ± 1.5 mm

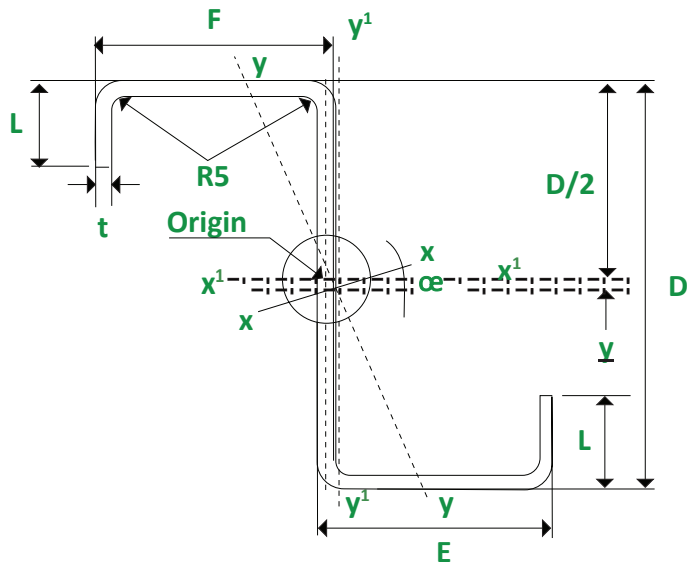
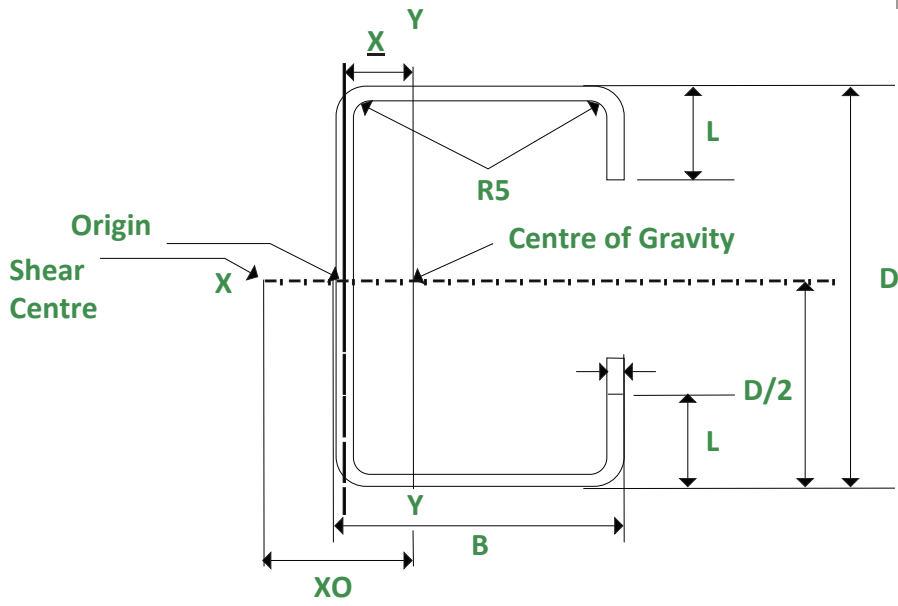

Where strength matters



C SECTION PROPERTIES

Section	Area mm ²	Second Moment of Area (x10 ⁶ mm ⁴)		Form Factor Q	Torsion Constant mm ⁴ J	Warping Constant (x10 ⁹ mm ⁶) I _w	Monosymmetry Constant mm b _y	Shear Centre mm x _o	Centre of Gravity x
		I _x	I _y						
C100 10	215	0.361	0.075	0.644	71.7	0.158	123.3	-39.85	16.03
C100 12	258	0.429	0.088	0.731	123.8	0.186	122.8	-39.61	15.93
C100 15	321.7	0.531	0.111	0.824	241.3	0.238	122	-39.9	16
C100 19	408.5	0.667	0.41	0.879	491.6	0.307	121.7	-40.28	16.18
C150 12	354	1.28	0.186	0.573	169.9	0.835	170.7	-46.38	18.22
C150 15	441.4	1.593	0.234	0.671	331	1.059	170.1	-46.7	18.3
C150 19	560.5	2.009	0.297	0.76	674.5	1.358	169.8	-47.07	18.49
C150 24	708	2.527	0.382	0.813	1359.4	1.79	168.5	-47.93	18.82
C200 15	555	3.509	0.393	0.557	416.3	3.042	223.2	-51.54	19.89
C200 19	710.7	4.472	0.522	0.647	855.2	4.157	220.8	-53.4	20.7
C200 24	901.5	5.642	0.673	0.726	1722.8	5.483	218.8	-54.2	21
C250 19	807.5	7.585	0.557	0.574	971.7	6.82	2764	-48.46	18.1
C250 24	1020	9.577	0.716	0.645	1958.4	8.859	273.9	-49.21	18.39
C300 24	1260	16.919	1.504	0.592	2419.2	26.671	319.8	-65.97	24.99
C300 30	1590	21.253	1.948	0.672	4770	35.487	315.8	-67.88	25.74
C350 24	1545	29.12	3.18	0.52	3015	77.379	386.9	-91.11	34.07
C350 30	1905	35.708	3.799	0.596	5715	89.651	378.4	-86.24	33.18
C400 24	1665	39.8	3.31	0.54	3246	103.979	439.9	-86.23	31.61
C400 30	2072	49.32	4.07	0.63	6318	127.269	440	-85.69	31.33

Z SECTION PROPERTIES

Section	Area mm ²	Second Moment of Area (x10 ⁶ mm ⁴)				Form Factor Q	Torsion Constant mm ⁴ J	Warping Constant (x10 ⁹ mm ⁶) I _w	Monosymmetry Constant mm		Shear Centre mm		Centre of Gravity		Angle (Deg) α
		I _x	I _y	I _x	I _y				b _x	b _y	x _o	y _o	x	y	
Z100 10	215	0.361	0.13	1.448	0.043	0.644	71.7	0.213	9.9	11.8	-1.94	-4.73	1.11	-0.94	27.6
Z100 12	258	0.429	0.153	0.532	0.051	0.731	123.8	0.25	9.9	11.8	-1.94	-4.75	1.11	-0.94	27.5
Z100 15	322.5	0.533	0.194	0.663	0.064	0.826	241.9	0.317	9.9	11.8	-1.95	-4.75	1.11	-0.94	27.8
Z100 19	408.5	0.667	0.248	0.833	0.081	0.879	491.6	0.404	9.9	11.7	-1.96	-4.77	1.12	-0.94	28
Z150 12	352.4	1.274	0.3	1.46	0.114	0.576	169.2	1.145	12.4	12.7	-1.9	-5.9	1	-1	21.7
Z150 15	441.4	1.586	0.379	1.822	0.144	0.676	331	1.447	12.4	12.6	-1.9	-5.9	1	-1	21.9
Z150 19	559.2	1.995	0.482	2.294	0.181	0.725	672.9	1.839	12.5	12.6	-1.9	-5.9	1	-1	22
Z150 24	705.9	2.506	0.625	2.897	0.235	0.811	1363.3	2.381	18.6	18.5	-2.9	-8.8	1.5	-1.5	22.4
Z200 15	555	3.512	0.616	3876	0.253	0.555	416.3	4.235	17.6	17.1	-2.26	-8.3	1.17	-1.36	18.5
Z200 19	712.5	4.496	0.837	4.994	0.339	0.647	857.4	5.795	17.4	16.8	-2.3	-8.24	1.19	-1.34	19.1
Z200 24	900	5.673	1.089	6.324	0.438	0.726	1728	7.58	21	19.8	-2.79	-9.94	1.45	-1.6	19.4
Z250 19	805.4	7.808	0.916	8.318	0.407	0.57	969.2	10.235	25.8	23.4	-2.7	-12.1	1.3	-1.9	14.7
Z250 24	1023.5	9.572	1.074	10.158	0.487	0.643	1952.5	12.261	26.9	23.4	-2.6	-12.8	1.3	-1.8	14.3
Z300 24	1260	17.117	2.381	18.471	1.027	0.59	2419.2	37.465	20.9	17.2	-1.99	-10.19	0.94	-1	16.2
Z300 30	1590	21.513	3.119	23.3	1.332	0.672	4770	49.318	21.3	16.9	-2.02	-10.42	0.94	-0.94	16.6
Z350 24	1545	29.1	4.98	32.02	2.07	0.52	2965	101	21.1	18.6	-2.1	-10.4	1.87	-2.16	18.2
Z350 30	1905	36.03	6.069	39.583	2.516	0.596	5715	126.23	21.6	19.1	-2.38	-10.49	1.16	-1.19	18
Z400 24	1665	39.8	4.98	42.55	2.22	0.54	3196	136	23.3	20.5	-2.4	-11.5	1.74	-2.29	15.2
Z400 30	2072	49.3	6.11	52.69	2.73	0.63	6250	166	23.7	21	-2.5	-11.8	1.73	-2.3	15.1



PRODUCT MANUAL – PURPOSE AND APPLICATION

How to Use This Manual

This manual lists detailed product capacities that should be considered during installation along with real applied loads. All spans are considered to be loaded concurrently, and allowances have not been made for uneven or skip loading. If loading conditions are likely to be inconsistent or vary from this manual, a structural engineer should be employed to verify compliance with AS/NZS 4600:2018.

Real loading capacity can vary widely, with reduced loading not enough to ensure competency. Member adequacy is also dependent on member profiles and movement application within the member span. Design actions can vary widely under applied loads, however, with each project design engineer needing to verify project specific material selection in compliance with AS/NZS 4600:2018 and AS/ANZ 1170 Assessed Loading.

Design Considerations and Assumptions

The information presented in this manual applies to limit state capacity. Any load amounts beyond tabulated totals will prevent the member from meeting its intended function. In this situation, potential outcomes include collapse and loss of structural integrity.

Limit state tables are listed for specific purlin combinations in order to affirm economic design solutions. In special projects, the following elements can be adjusted to optimise design: material specifications, bolt quantity, bolt specifications, bridging quantity, span range, lap length, end span sizes, cantilevers, and loading requirements.

All design calculations are based on AS/NZS 4600:2018 Cold Formed Steel Structures. All measurements are based on industry best practice.

Assumptions inherent in and validated by code provisions:

- The Z shaped section behaves as an equivalent C shaped channel.
- In regard to its initial displacement, the Z shaped section may be seen as physically attached to and acting with the sheeting incurring the loads.
- For Inward loading, full compressive bending

stress is allowed on the flange that is attached to the sheeting. The following diagram shows the centre span condition.

- For Outward loading, full compressive bending stress is allowed on the flange that is attached to the sheeting. The following diagram shows span support condition.
- For any sections or lengths that experience distortions or buckling effects, bending moment gradient and magnitude are considered.
- For all systems, loading distribution is assumed to be uniform and acting on all spans simultaneously.
- All section properties have been calculated with the holes deducted from the web.

LOADING CONDITIONS

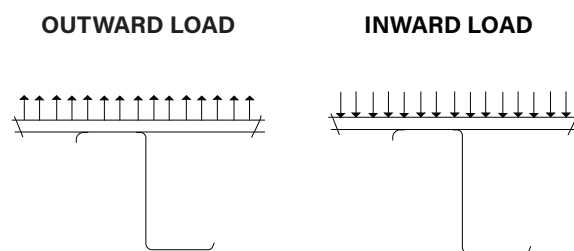

Design Considerations and Assumptions Disclaimer

This document is intended to provide accurate information relating to Millform **Archetype™** C and Z purlins. It does not attempt to provide a complete description of the products. It does not describe the suitability of materials for specific projects or applications. All published information is intended as a guide only. Millform Pty Ltd does not accept any liability for loss or damage resulting from the use of data in this document.





DESIGN & SPECIFICATION

Hole Punching

Millform *Archetype Purlin™* C and Z purlin sections are typically supplied with hole punch measurements that comply with the AISC guide. Measurements are different in Victoria, however, with 150 mm sections punched with 70 mm centres in accordance with Structural Steel Fabricator Association Victoria guidelines.

Punched holes are needed at cleat supports, laps, bridging points, and other locations as specified on data sheets prior to manufacture. Our system is left-to-right cumulative from one end to ensure accuracy. A complete purlin length measurement is needed to enable a data entry dimensional check.

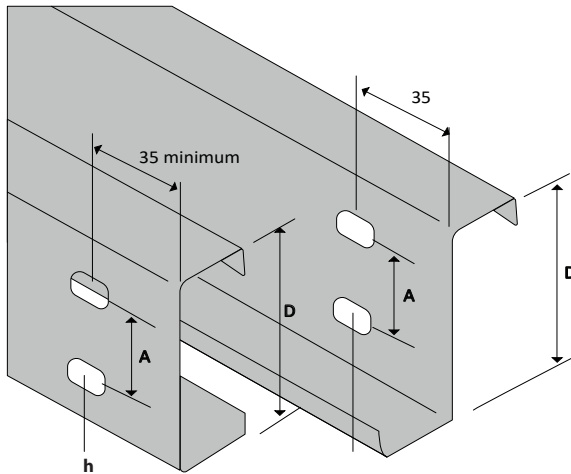

HOLE CENTRES

PURLIN SIZE	AISC CENTRES	
	A mm	h mm
D mm		
100	40	18 x 22
150	60*	18 x 22
200	110	18 x 22
250	160	18 x 22
300	210	22 round
350	260	22 round
400	310	25 round

* Standard centres in VIC is 70mm

Alternative hole sizes, shapes and centres are available.

Please enquire with your local Millform branch.

Structural Lap Lengths

Millform Z sections feature one broad flange and one narrow flange in direct proportion. If both sections are the same size, and one section is rotated by 180 degrees, they can be fitted and will align with a bolt connection. This makes them suitable for lapping. While structural continuity enables improved economy, lapping helps to increase strength, improve load capacity, and enhance system rigidity. C sections can't be lapped.

When Z sections are lapped, there are two thicknesses installed over interior supports. Depending on the length of the lap, this can alter deflection and reaction coefficients along with bending movements. These elements are determined by a nominal lap of 10% span in all lapped spans. When a lighter internal section combines with a heavier gauge end span, the difference in thickness accounts for a maximum of two sections.

At more complex points with three or four lapped span configurations, the greater thickness exists in the end spans. Regardless of configuration, the structural lap at interior supports must provide enough structural continuity. Each lap end must be bolted, with one bolt placed through the flanges furthest from the cladding and another bolt placed through the webs near the flanges connected to the cladding.

Multiple Z sections with the same thickness measurements can be lapped in any configuration. Z sections can be used over simple spans and applied continuously over two or more shorter spans without laps. Z sections with a single lip turned outwards can be used with the ends butted in simple or continuous spans; however, these sections can't be overlapped.

In terms of bridging, three rows should be selected, with additional rows offering no benefits. Bridging should be selected and installed with a maximum un-braced length of 20 x D (purlin height) or 4,000 mm. This helps to enhance purlin performance and also assists with the installation of roof sheeting. A design engineer should assist in locating an ideal bridging location to the nearest 50 mm.

LAP LENGTHS

Nominal Section Size (mm)	Span (mm)	Lap Length (mm)
100	≤6000	600
	>6000	900
150, 200, 250	≤9000	900
	>9000≤12000	1200
	>1200	1800
300, 350	≤9000	900
	>9000≤12000	1200
	>1200≤1800	1800
	>18000	2400

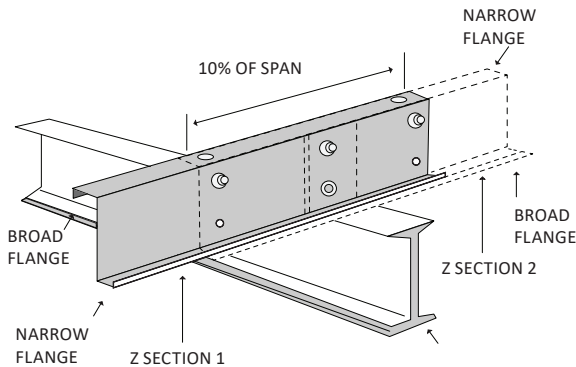

DOUBLE OR END SPANS

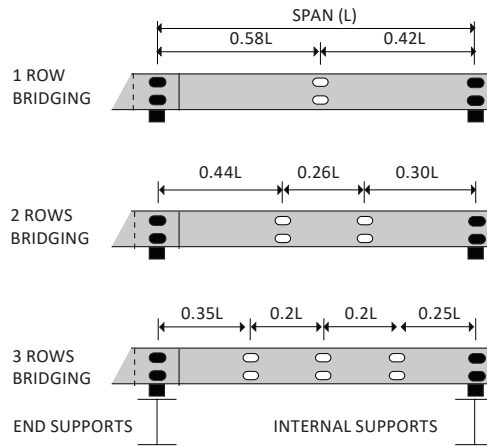

Member Weight

Limit state loads are measured in kN/m and make no allowance for the mass of the member. In some cases, limit state loads are limited by the bolting.

Deflection

Structural codes provide guidance surrounding deflections; however, there are no specific rules in place. It's important to consider the specific requirements of the structure in question. It may be necessary to design under multiple load combinations, with critical span loads calculated with a deflection of $Span/150$.

Cleat Connections

Limit state capacity for cleat connections is based on sections being fastened through the web to the cleats. When this occurs, the load is transferred through the section web. This connection can be either single section thickness, like it is for end connections, or as an internal support for continuous configurations. Connections with double section thickness occur at the internal support point of lapped configurations.

With this style of connection, two bolts are used, with the size and grade of each bolt based on the overall size and design load of the section. In many cases, it's possible to eliminate cleats and bolts through the bottom flange of the Z and C sections. Overall, the number of bolts is halved compared to conventional cleated mechanisms.

Single cleats are often used with Z sections, and double cleats are used with C sections. Double cleats are also applied when there is a high reaction load used to reduce bolt stress and shear. Extra care is needed in the case of hole detailing for double cleat applications to a single purlin. Industry standard sizes and purlin clearances are illustrated in the following table.

BRIDGING

The limit state capacity tables provide design solutions for an equal number of rows of bridging in each span. Provision is made for 0, 1, 2 or 3 rows.

RECOMMENDED MAX. BRIDGING SPACING

PURLIN SIZE MM	MAX. BRIDGING SPACING MM
100	2000
150	3000
200, 250, 300, 350, 400	4000

BRIDGING HOLE LOCATIONS

SINGLE OR INTERNAL SPANS

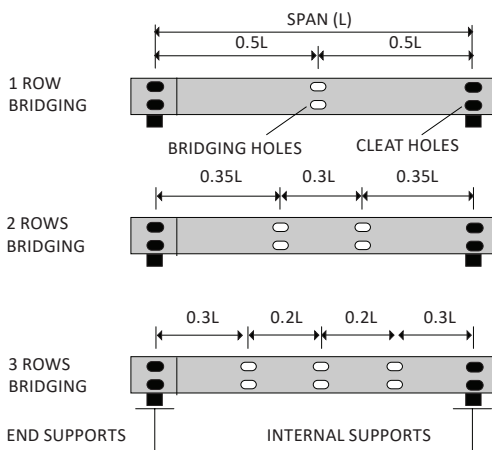



CLEAT NOMINAL DIMENSIONS - MM

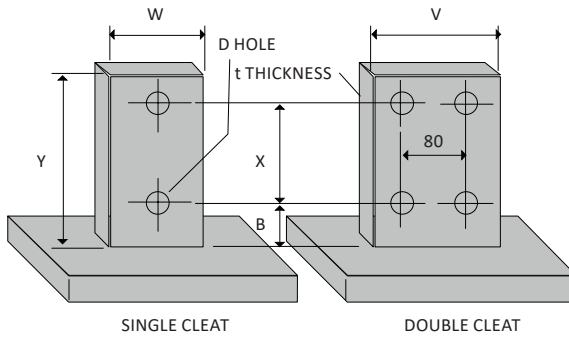

SIZE	X	B+	Y+	t	GAP	hd	W	V
100	40	40	105	8	10	18	50	130
150	60*	50†	145	8	10	18	60	140
200	110	55	195	8	10	18	60	140
250	160	55	245	8	10	18	60	140
300	210	65	305	12	20	22	60	140
350	260	65	355	12	20	22	60	140
400	310	75	405	12	20	22	60	104

* 70mm in VIC

† 50mm in VIC

+ When using down turned lip purlins or girts the lip length must be added to the dimension B and Y. Cleat lengths may be increased in some design situations (e.g. above an expansion joint).

As a guide, increase the cleat thickness by 2mm for each 40mm of additional length.

BOLTS

When you fasten sections to cleats, standard bolts are required. High strength bolts are also needed for some applications, with this situation marked in the limit state capacity tables. In these situations, the overall section capacity is not fully utilised, and an alternative configuration may be more economical. It may also be possible to change the spacing or increase the number of bolts in the section.

Purlin laps need to be bolted to the top web hole and lower flange holes at both ends of the lap. If only the web is bolted, excessive loads can be placed on roofing screws and structural integrity is compromised. It's important that all bolts are tightened prior to roof installation, and the design engineer ensures the correct size and grade of purlin bolts.

BOLT SPECIFICATION

NOMINAL SECTION SIZE MM	BOLT SPECIFICATION
100, 150, 200, 250	Standard M12 Purlin Bolt High Strength M12 Purlin Bolt
300, 350, 400	Standard M16 Purlin Bolt High Strength M16 Purlin Bolt

Point Loads (SEE TABLE OVER PAGE)

The limit state loads listed in the following tables are distributed evenly based on uniform values. There are key differences based on applications, with all design loads needing to be converted to ensure correct use. In some applications, design loads are point loads. Point-loaded configurations have been linked to uniformly loaded configurations and presented with the correct conversion. For continuous unlapped configurations, a different conversion formula is needed.

In the case of single spans, the formula given is accurate. For lapped spans, the accuracy of the conversion is dependent on the number of spans, their position in the continuity, and the lapping ratio. The lapped span formula shown is based on worst-case loading conditions, which means it can be safely applied for interior spans, end spans, and lapping ratios greater than 0:10. A separate set of conversion formula is needed for deflections.

LOADING CONDITION		DIAGRAM	CONVERSION FORMULA
SINGLE LOAD	Simple		$w = \frac{2P}{L}$
	Lapped		$w = \frac{2.22P}{L}$
2 LOADS	Simple		$w = \frac{2.67P}{L}$
	Lapped		$w = \frac{3.16P}{L}$
3 LOADS	Simple		$w = \frac{4P}{L}$
	Lapped		$w = \frac{3.78P}{L}$
4 LOADS	Simple		$w = \frac{4.80P}{L}$
	Lapped		$w = \frac{5.12P}{L}$
5 LOADS	Simple		$w = \frac{6P}{L}$
	Lapped		$w = \frac{6.65P}{L}$
6 OR MORE LOADS	Simple		$w = \frac{1.14P}{L}$
	Lapped		$w = \frac{1.22P}{L}$

SINGLE ECCENTRIC & TWO SYMMETRICAL POINT LOADS

SINGLE ECCENTRIC POINT LOAD	Simple		$w = \frac{8abP}{L^3}$
	Lapped		$w = \frac{17.76abP}{L^4}$
TWO SYMMETRICAL POINT LOADS	Simple		$w = \frac{8bP}{L^2}$
	Lapped		$w = \frac{9.45(2L-3b)P}{L^3}$

P = Single Point Load (kN)
 L = Span (m)
 a = Larger distance from support (m)
 b = Smaller distance from support (m)
 w = Equivalent uniform load (kN/m)
 N = Number of Point Loads over one span

Where strength matters





HOW TO USE THE TABLES

The tables shown below highlight the maximum limit state capacity of the sections. Capacities are based on loads that have been distributed uniformly, with any point loads needing to be converted. Required loads need to be established by a project designer using the correct building codes and standards. It's important to calculate the purlin and girt outward and inward loads based on the preferred span configuration. The Hookfast bridging system can be used for 3 rows of bridging.

SINGLE SPAN

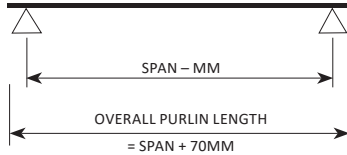

2 SPAN CONTINUOUS UNLAPPED

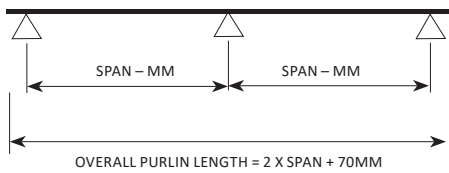

2 SPAN LAPPED

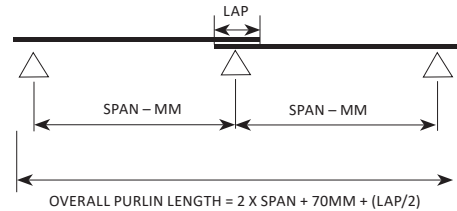

3 SPAN CONTINUOUS UNLAPPED

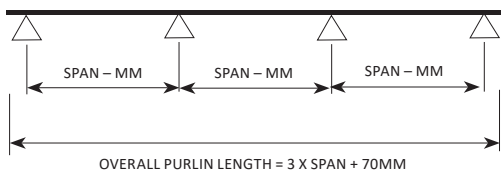

3 SPAN LAPPED

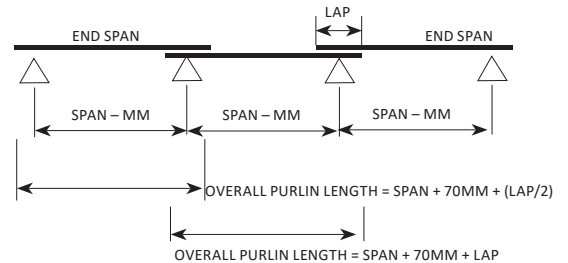

4 SPAN CONTINUOUS UNLAPPED

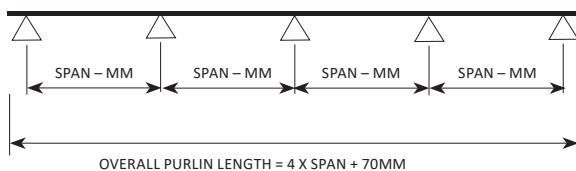

4 SPAN LAPPED

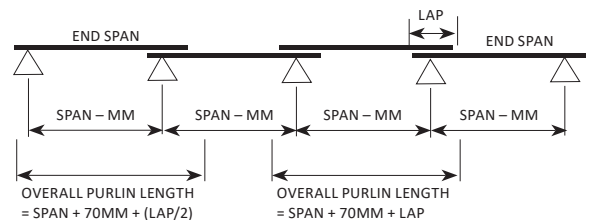

LOAD CAPACITY TABLES

C75 SINGLE SPAN

Single Spans are simply supported at each end of the purlin.

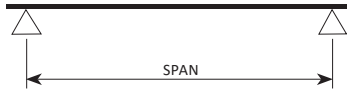

Span	C 75 - 9.5						
	Inward			Intward			Def'n L/150
	0	1	2	0	1	2	
1000	10.49	10.49	10.49	10.49	10.49	10.49	13.35
1500	4.66	4.66	4.66	4.31	4.66	4.66	3.96
2000	2.62	2.62	2.62	1.86	2.62	2.62	1.67
2500	1.68	1.68	1.68	0.88	1.61	1.68	0.86
3000	1.17	1.17	1.17	0.46	0.98	1.17	0.50
3500	0.86	0.86	0.86	0.27	0.61	0.84	0.31
4000	0.66	0.66	0.66	0.17	0.38	0.60	0.21
4500	0.52	0.52	0.52	0.11	0.26	0.43	0.15

Span	C 75 - 12						
	Inward			Intward			Def'n L/150
	0	1	2	0	1	2	
1000	13.88	13.88	13.88	13.88	13.88	13.88	17.14
1500	6.17	6.17	6.17	5.57	6.17	6.17	5.08
2000	3.47	3.47	3.47	2.59	3.47	3.47	2.14
2500	2.22	2.22	2.22	1.21	2.06	2.22	1.10
3000	1.54	1.54	1.54	0.65	1.30	1.54	0.64
3500	1.13	1.13	1.13	0.38	0.85	1.07	0.40
4000	0.86	0.87	0.87	0.24	0.54	0.78	0.27
4500	0.68	0.69	0.69	0.17	0.35	0.57	0.19

Span	C 75 - 15						
	Inward			Intward			Def'n L/150
	0	1	2	0	1	2	
1000	17.61	17.61	17.61	17.61	17.61	17.61	21.85
1500	7.77	7.83	7.83	6.96	7.83	7.83	6.48
2000	4.30	4.40	4.40	3.29	4.35	4.40	2.73
2500	2.72	2.82	2.82	1.67	2.58	2.82	1.40
3000	1.87	1.96	1.96	0.89	1.64	1.92	0.81
3500	1.37	1.44	1.44	0.54	1.08	1.34	0.51
4000	1.04	1.10	1.10	0.35	0.73	0.97	0.34
4500	0.82	0.87	0.87	0.25	0.48	0.72	0.24

C75 CONTINUOUS SPAN

Two continuous spans are continuous over two bays of equal span, supported at each end of the purlin and over a central support.

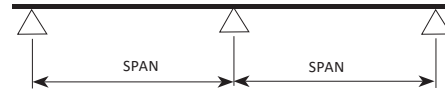

Span	C 75 - 9.5						
	Inward			Intward			Def'n L/150
	0	1	2	0	1	2	
1000	10.36	10.36	10.36	10.36	10.36	10.36	32.21
1500	4.66	4.66	4.66	4.66	4.66	4.66	9.54
2000	2.62	2.62	2.62	2.62	2.62	2.62	4.03
2500	1.68	1.68	1.68	1.68	1.68	1.68	2.06
3000	1.17	1.17	1.17	1.09	1.17	1.17	1.19
3500	0.86	0.86	0.86	0.72	0.85	0.86	0.75
4000	0.65	0.66	0.66	0.49	0.61	0.66	0.50
4500	0.50	0.52	0.52	0.34	0.44	0.52	0.35

Span	C 75 - 12						
	Inward			Intward			Def'n L/150
	0	1	2	0	1	2	
1000	13.67	13.67	13.68	13.68	13.68	13.68	41.32
1500	6.17	6.17	6.17	6.17	6.17	6.17	12.24
2000	3.47	3.47	3.47	3.47	3.47	3.47	5.17
2500	2.21	2.22	2.22	2.16	2.22	2.22	2.65
3000	1.51	1.54	1.54	1.41	1.54	1.54	1.53
3500	1.09	1.13	1.13	0.96	1.08	1.13	0.96
4000	0.82	0.87	0.87	0.68	0.79	0.87	0.65
4500	0.63	0.69	0.69	0.49	0.59	0.67	0.45

Span	C 75 - 15						
	Inward			Intward			Def'n L/150
	0	1	2	0	1	2	
1000	16.96	16.96	16.96	16.96	16.96	16.96	52.70
1500	7.83	7.83	7.83	7.83	7.83	7.83	15.62
2000	4.31	4.40	4.40	4.40	4.40	4.40	6.59
2500	2.71	2.82	2.82	2.70	2.82	2.82	3.37
3000	1.85	1.96	1.96	1.77	1.93	1.96	1.95
3500	1.33	1.44	1.44	1.22	1.36	1.44	1.23
4000	1.00	1.10	1.10	0.87	0.99	1.10	0.82
4500	0.78	0.87	0.87	0.64	0.74	0.84	0.58

NOTE: All gauges of section C75 require M12 grade 4.6 bolts.

Where strength matters



Single Spans are simply supported at each end with the purlin.



Where strength matters



Span	C/Z 100 - 10											
	Inward				Intward				Def'n L/150			
	0	1	2	3	0	1	2	3				
1500	8.00	8.00	8.00	8.00	8.00	8.00	8.00	8.00	10.12			
2000	4.50	4.50	4.50	4.50	4.24	4.50	4.50	4.50	4.27			
2500	2.88	2.88	2.88	2.88	2.17	2.88	2.88	2.88	2.19			
3000	2.00	2.00	2.00	2.00	1.14	2.00	2.00	2.00	1.26			
3500	1.47	1.47	1.47	1.47	0.68	1.40	1.47	1.47	0.80			
4000	1.13	1.13	1.13	1.13	0.43	0.95	1.13	1.13	0.53			
4500	0.89	0.89	0.89	0.89	0.28	0.65	0.89	0.89	0.38			
5000	0.72	0.72	0.72	0.72	0.19	0.45	0.70	0.72	0.27			
5500	0.60	0.60	0.60	0.60	0.14	0.32	0.54	0.60	0.21			
6000	0.50	0.50	0.50	0.50	0.10	0.24	0.41	0.50	0.16			
6500	0.43	0.43	0.43	0.43	0.08	0.18	0.32	0.43	0.12			
7000	0.37	0.37	0.37	0.37	0.06	0.14	0.25	0.35	0.10			
7500	0.32	0.32	0.32	0.32	0.05	0.11	0.19	0.29	0.08			
8000	0.28	0.28	0.28	0.28	0.04	0.09	0.15	0.24	0.07			

Span	C/Z 100 - 12											
	Inward				Intward				Def'n L/150			
	0	1	2	3	0	1	2	3				
1500	9.71	9.71	9.71	9.71	9.71	9.71	9.71	9.71	12.22			
2000	5.46	5.46	5.46	5.46	4.99	5.46	5.46	5.46	5.16			
2500	3.50	3.50	3.50	3.50	2.65	3.50	3.50	3.50	2.64			
3000	2.43	2.43	2.43	2.43	1.45	2.42	2.43	2.43	1.53			
3500	1.78	1.78	1.78	1.78	0.86	1.65	1.78	1.78	0.96			
4000	1.37	1.37	1.37	1.37	0.53	1.14	1.37	1.37	0.65			
4500	1.08	1.08	1.08	1.08	0.35	0.80	1.07	1.08	0.45			
5000	0.87	0.87	0.87	0.87	0.24	0.56	0.82	0.87	0.33			
5500	0.72	0.72	0.72	0.72	0.17	0.41	0.64	0.72	0.25			
6000	0.60	0.61	0.61	0.61	0.13	0.30	0.50	0.61	0.19			
6500	0.51	0.52	0.52	0.52	0.10	0.22	0.39	0.50	0.15			
7000	0.44	0.45	0.45	0.45	0.08	0.17	0.31	0.41	0.12			
7500	0.38	0.39	0.39	0.39	0.06	0.13	0.24	0.34	0.10			
8000	0.33	0.34	0.34	0.34	0.05	0.11	0.19	0.29	0.08			

Span	C/Z 100 - 15											
	Inward				Intward				Def'n L/150			
	0	1	2	3	0	1	2	3				
1500	12.64	12.64	12.64	12.64	12.64	12.64	12.64	12.64	15.56			
2000	6.96	7.11	7.11	7.11	6.38	7.11	7.11	7.11	6.57			
2500	4.39	4.55	4.55	4.55	3.57	4.55	4.55	4.55	3.36			
3000	3.01	3.16	3.16	3.16	2.00	3.04	3.16	3.16	1.95			
3500	2.19	2.32	2.32	2.32	1.17	2.10	2.32	2.32	1.23			
4000	1.67	1.78	1.78	1.78	0.73	1.50	1.76	1.78	0.82			
4500	1.31	1.41	1.41	1.41	0.48	1.09	1.34	1.41	0.58			
5000	1.05	1.14	1.14	1.14	0.34	0.78	1.04	1.14	0.42			
5500	0.87	0.94	0.94	0.94	0.24	0.55	0.82	0.93	0.32			
6000	0.73	0.79	0.79	0.79	0.18	0.41	0.66	0.76	0.24			
6500	0.62	0.67	0.67	0.67	0.14	0.31	0.53	0.63	0.19			
7000	0.53	0.58	0.58	0.58	0.11	0.23	0.42	0.53	0.15			
7500	0.46	0.51	0.51	0.51	0.09	0.18	0.34	0.44	0.13			
8000	0.40	0.45	0.45	0.45	0.08	0.14	0.27	0.38	0.10			

Span	C/Z 100 - 19											
	Inward				Intward				Def'n L/150			
	0	1	2	3	0	1	2	3				
1500	17.10	17.61	17.61	17.61	17.21	17.61	17.61	17.61	20.05			
2000	9.29	9.91	9.90	9.90	8.64	9.91	9.90	9.91	8.46			
2500	5.80	6.34	6.34	6.34	4.78	6.33	6.34	6.34	4.33			
3000	3.96	4.40	4.40	4.40	2.76	4.17	4.40	4.40	2.51			
3500	2.87	3.23	3.23	3.23	1.61	2.86	3.23	3.23	1.58			
4000	2.17	2.48	2.48	2.48	1.02	2.02	2.42	2.48	1.06			
4500	1.70	1.96	1.96	1.96	0.69	1.46	1.84	1.96	0.74			
5000	1.37	1.58	1.59	1.59	0.49	1.07	1.42	1.58	0.54			
5500	1.12	1.30	1.31	1.31	0.36	0.77	1.12	1.28	0.41			
6000	0.94	1.09	1.10	1.10	0.28	0.56	0.89	1.04	0.31			
6500	0.79	0.93	0.94	0.94	0.22	0.42	0.71	0.86	0.25			
7000	0.68	0.80	0.81	0.81	0.18	0.32	0.57	0.72	0.20			
7500	0.59	0.69	0.70	0.70	0.14	0.26	0.46	0.60	0.16			
8000	0.52	0.61	0.62	0.62	0.12	0.20	0.37	0.51	0.13			

Span	C/Z 100 - 24											
	Inward				Intward				Def'n L/150			
	0	1	2	3	0	1	2	3				
1500	21.46	22.85	22.85	22.85	21.94	22.85	22.85	22.85	25.04			
2000	11.64	12.85	12.85	12.85	11.25	12.85	12.85	12.85	10.56			
2500	7.27	8.23	8.23	8.23	6.24	8.07	8.23	8.23	5.41			
3000	4.95	5.71	5.71	5.71	3.64	5.34	5.71	5.71	3.13			
3500	3.57	4.14	4.20	4.20	2.19	3.72	4.16	4.20	1.97			
4000	2.70	3.14	3.21	3.21	1.42	2.65	3.09	3.21	1.32			
4500	2.11	2.46	2.54	2.54	0.98	1.92	2.36	2.54	0.93			
5000	1.69	1.98	2.06	2.06	0.71	1.40	1.84	2.02	0.68			
5500	1.39	1.63	1.69	1.70	0.54	1.04	1.46	1.63	0.51			
6000	1.16	1.36	1.41	1.43	0.42	0.77	1.16	1.34	0.39			
6500	0.98	1.15	1.19	1.22	0.33	0.58	0.93	1.11	0.31			
7000	0.84	0.99	1.02	1.05	0.27	0.46	0.75	0.93	0.25			
7500	0.73	0.86	0.89	0.91	0.23	0.36	0.61	0.79	0.20			
8000	0.64	0.75	0.78	0.80	0.19	0.29	0.49	0.67	0.17			

NOTE: All gauges of section C/Z 100 require M12 grade 4.6 bolts.

SINGLE SPAN

Single Spans are simply supported at each end with the purlin.

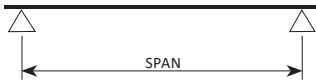

Span	C/Z 150 - 10											
	Inward				Intward				Def'n L/150			
	0	1	2	3	0	1	2	3				
2000	6.21	6.21	6.21	6.21	6.21	6.21	6.21	6.21	12.00			
2500	4.85	4.85	4.85	4.85	4.55	4.85	4.85	4.85	6.14			
3000	3.37	3.37	3.37	3.37	2.76	3.37	3.37	3.37	3.55			
3500	2.47	2.47	2.47	2.47	1.71	2.47	2.47	2.47	2.24			
4000	1.89	1.89	1.89	1.89	1.06	1.88	1.89	1.89	1.50			
4500	1.50	1.50	1.50	1.50	0.70	1.40	1.50	1.50	1.05			
5000	1.21	1.21	1.21	1.21	0.48	1.05	1.21	1.21	0.77			
5500	1.00	1.00	1.00	1.00	0.35	0.79	1.00	1.00	0.58			
6000	0.84	0.84	0.84	0.84	0.26	0.60	0.83	0.84	0.44			
6500	0.71	0.72	0.72	0.72	0.19	0.46	0.68	0.72	0.35			
7000	0.61	0.62	0.62	0.62	0.14	0.35	0.56	0.62	0.28			
7500	0.53	0.54	0.54	0.54	0.11	0.27	0.46	0.54	0.23			
8000	0.47	0.47	0.47	0.47	0.09	0.22	0.38	0.47	0.19			
8500	0.41	0.42	0.42	0.42	0.07	0.17	0.31	0.40	0.16			
9000	0.37	0.37	0.37	0.37	0.06	0.14	0.26	0.35	0.13			
9500	0.33	0.34	0.34	0.34	0.05	0.12	0.21	0.30	0.11			
10000	0.30	0.30	0.30	0.30	0.04	0.10	0.18	0.26	0.10			

Span	C/Z 150 - 12											
	Inward				Intward				Def'n L/150			
	0	1	2	3	0	1	2	3				
2000	9.42	9.42	9.42	9.42	9.42	9.42	9.42	9.42	14.90			
2500	6.03	6.03	6.03	6.03	5.93	6.03	6.03	6.03	7.63			
3000	4.19	4.19	4.19	4.19	3.60	4.19	4.19	4.19	4.41			
3500	3.08	3.08	3.08	3.08	2.14	3.08	3.08	3.08	2.78			
4000	2.35	2.35	2.35	2.35	1.33	2.35	2.35	2.35	1.86			
4500	1.86	1.86	1.86	1.86	0.89	1.82	1.86	1.86	1.31			
5000	1.51	1.51	1.51	1.51	0.62	1.38	1.51	1.51	0.95			
5500	1.25	1.25	1.25	1.25	0.44	1.03	1.25	1.25	0.72			
6000	1.05	1.05	1.05	1.05	0.32	0.76	1.05	1.05	0.55			
6500	0.89	0.89	0.89	0.89	0.24	0.57	0.88	0.89	0.43			
7000	0.77	0.77	0.77	0.77	0.18	0.44	0.73	0.77	0.35			
7500	0.67	0.67	0.67	0.67	0.14	0.34	0.60	0.67	0.28			
8000	0.58	0.59	0.59	0.59	0.11	0.28	0.49	0.59	0.23			
8500	0.51	0.52	0.52	0.52	0.09	0.22	0.40	0.52	0.19			
9000	0.46	0.47	0.47	0.47	0.07	0.18	0.33	0.46	0.16			
9500	0.41	0.42	0.42	0.42	0.06	0.15	0.27	0.40	0.14			
10000	0.37	0.38	0.38	0.38	0.05	0.12	0.22	0.35	0.12			

Span	C/Z 150 - 15											
	Inward				Intward				Def'n L/150			
	0	1	2	3	0	1	2	3				
2000	12.40	12.40	12.40	12.40	12.40	12.40	12.40	12.40	19.34			
2500	7.93	7.93	7.93	7.93	7.57	7.93	7.93	7.93	9.90			
3000	5.48	5.51	5.51	5.51	4.62	5.51	5.51	5.51	5.73			
3500	3.96	4.05	4.05	4.05	2.87	4.05	4.05	4.05	3.61			
4000	2.99	3.10	3.10	3.10	1.84	3.10	3.10	3.10	2.42			
4500	2.33	2.45	2.45	2.45	1.20	2.33	2.45	2.45	1.70			
5000	1.87	1.98	1.98	1.98	0.83	1.76	1.98	1.98	1.24			
5500	1.53	1.64	1.64	1.64	0.58	1.34	1.64	1.64	0.93			
6000	1.28	1.38	1.38	1.38	0.42	1.02	1.38	1.38	0.72			
6500	1.08	1.17	1.17	1.17	0.32	0.78	1.13	1.17	0.56			
7000	0.93	1.01	1.01	1.01	0.24	0.61	0.93	1.01	0.45			
7500	0.80	0.88	0.88	0.88	0.19	0.47	0.77	0.88	0.37			
8000	0.70	0.78	0.78	0.78	0.15	0.37	0.64	0.78	0.30			
8500	0.62	0.69	0.69	0.69	0.12	0.30	0.53	0.68	0.25			
9000	0.55	0.61	0.61	0.61	0.10	0.24	0.44	0.58	0.21			
9500	0.49	0.55	0.55	0.55	0.08	0.20	0.37	0.51	0.18			
10000	0.44	0.50	0.50	0.50	0.07	0.16	0.31	0.44	0.16			

Span	C/Z 150 - 19											
	Inward				Intward				Def'n L/150			
	0	1	2	3	0	1	2	3				
2000	17.00	17.50	17.50	17.50	17.41	17.50	17.50	17.50	24.75			
2500	10.51	11.20	11.20	11.20	10.24	11.20	11.20	11.20	12.67			
3000	7.11	7.78	7.78	7.78	6.37	7.78	7.78	7.78	7.33			
3500	5.11	5.72	5.72	5.72	3.97	5.72	5.72	5.72	4.62			
4000	3.85	4.38	4.38	4.38	2.48	4.21	4.38	4.38	3.09			
4500	3.00	3.46	3.46	3.46	1.62	3.16	3.46	3.46	2.17			
5000	2.40	2.80	2.80	2.80	1.10	2.41	2.80	2.80	1.58			
5500	1.96	2.32	2.32	2.32	0.78	1.86	2.28	2.32	1.19			
6000	1.63	1.95	1.95	1.95	0.57	1.43	1.86	1.95	0.92			
6500	1.38	1.66	1.66	1.66	0.43	1.08	1.53	1.66	0.72			
7000	1.18	1.43	1.43	1.43	0.34	0.82	1.27	1.43	0.58			
7500	1.02	1.24	1.25	1.25	0.27	0.64	1.06	1.23	0.47			
8000	0.89	1.08	1.09	1.09	0.22	0.50	0.89	1.05	0.39			
8500	0.79	0.95	0.97	0.97	0.18	0.40	0.74	0.91	0.32			
9000	0.70	0.85	0.86	0.86	0.15	0.32	0.62	0.79	0.27			
9500	0.62	0.76	0.78	0.78	0.12	0.27	0.51	0.69	0.23			
10000	0.56	0.68	0.70	0.70	0.11	0.22	0.42	0.60	0.20			

Span	C/Z 150 - 24											
	Inward				Intward				Def'n L/150			
	0	1	2	3	0	1	2	3				
2000	22.64	24.54	24.54	24.54	23.92	24.54	24.54	24.54	31.92			
2500	13.76	15.71	15.71	15.71	13.89	15.71	15.71	15.71	16.34			
3000	9.18	10.91	10.91	10.91	8.54	10.91	10.91	10.91	9.46			
3500	6.53	8.01	8.01	8.01	5.40	7.91	8.01	8.01	5.96			
4000	4.87	6.14	6.14	6.14	3.34	5.76	6.14	6.14	3.99			
4500	3.77	4.84	4.85	4.85	2.18	4.30	4.85	4.85	2.80			
5000	3.00	3.87	3.93	3.93	1.50	3.26	3.91	3.93	2.04			
5500	2.44	3.16	3.25	3.25	1.08	2.50	3.13	3.25	1.54			
6000	2.02	2.63	2.73	2.73	0.80	1.94	2.54	2.73	1.18			
6500	1.70	2.22	2.32	2.32	0.62	1.48	2.08	2.32	0.93			
7000	1.45	1.90	2.00	2.00	0.48	1.12	1.72	1.98	0.75			
7500	1.25	1.64	1.74	1.75	0.39	0.87	1.43	1.69	0.61			
8000	1.09	1.43	1.52	1.53	0.32	0.68	1.19	1.44	0.50			
8500	0.96	1.26	1.34	1.36	0.26	0.55	1.00	1.24	0.42			
9000	0.85	1.12	1.18	1.21	0.22	0.45	0.84	1.08	0.35			
9500	0.76	1.00	1.06	1.09	0.19	0.37	0.70	0.94	0.30			
10000	0.68	0.90	0.95	0.98	0.16	0.31	0.58	0.82	0.26			

Where strength matters



NOTE: All gauges of section C/Z 150 require M12 grade 4.6 bolts.

Single Spans are simply supported at each end with the purlin.

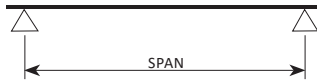

Where strength matters

Span	C/Z 200 - 12											
	Inward				Intward				Def'n L/150			
	0	1	2	3	0	1	2	3				
2500	6.31	6.31	6.31	6.31	6.31	6.31	6.31	6.31	15.87			
3000	5.26	5.26	5.26	5.26	5.26	5.26	5.26	5.26	9.18			
3500	4.22	4.24	4.25	4.24	3.59	4.24	4.25	4.24	5.78			
4000	3.19	3.25	3.25	3.25	2.40	3.25	3.25	3.25	3.87			
4500	2.49	2.57	2.57	2.57	1.67	2.57	2.57	2.57	2.72			
5000	2.00	2.08	2.08	2.08	1.15	2.02	2.08	2.08	1.98			
5500	1.64	1.72	1.72	1.72	0.82	1.59	1.72	1.72	1.49			
6000	1.37	1.44	1.44	1.44	0.60	1.26	1.44	1.44	1.15			
6500	1.16	1.23	1.23	1.23	0.46	1.00	1.23	1.23	0.90			
7000	0.99	1.06	1.06	1.06	0.35	0.79	1.05	1.06	0.72			
7500	0.86	0.92	0.92	0.92	0.27	0.64	0.89	0.92	0.59			
8000	0.75	0.81	0.81	0.81	0.22	0.52	0.75	0.81	0.48			
8500	0.66	0.72	0.72	0.72	0.17	0.42	0.64	0.72	0.40			
9000	0.59	0.64	0.64	0.64	0.14	0.34	0.55	0.64	0.34			
9500	0.53	0.58	0.58	0.58	0.11	0.28	0.47	0.57	0.29			
10000	0.47	0.52	0.52	0.52	0.09	0.23	0.40	0.51	0.25			
10500	0.43	0.47	0.47	0.47	0.08	0.20	0.35	0.45	0.21			
11000	0.39	0.43	0.43	0.43	0.07	0.17	0.30	0.40	0.19			
11500	0.35	0.39	0.39	0.39	0.06	0.14	0.26	0.35	0.16			
12000	0.32	0.36	0.36	0.36	0.05	0.12	0.22	0.32	0.14			

Span	C/Z 200 - 15											
	Inward				Intward				Def'n L/150			
	0	1	2	3	0	1	2	3				
2500	11.09	11.09	11.09	11.09	11.09	11.09	11.09	11.09	20.85			
3000	7.70	7.70	7.70	7.70	7.68	7.70	7.70	7.70	12.06			
3500	5.66	5.66	5.66	5.66	5.20	5.66	5.66	5.66	7.60			
4000	4.33	4.33	4.33	4.33	3.39	4.33	4.33	4.33	5.09			
4500	3.38	3.42	3.42	3.42	2.23	3.42	3.42	3.42	3.58			
5000	2.71	2.77	2.77	2.77	1.54	2.77	2.77	2.77	2.61			
5500	2.22	2.29	2.29	2.29	1.12	2.26	2.29	2.29	1.96			
6000	1.85	1.93	1.93	1.93	0.82	1.82	1.93	1.93	1.51			
6500	1.57	1.64	1.64	1.64	0.61	1.44	1.64	1.64	1.19			
7000	1.34	1.41	1.41	1.41	0.47	1.13	1.41	1.41	0.95			
7500	1.16	1.23	1.23	1.23	0.36	0.88	1.23	1.23	0.77			
8000	1.02	1.08	1.08	1.08	0.28	0.70	1.07	1.08	0.64			
8500	0.90	0.96	0.96	0.96	0.23	0.56	0.92	0.96	0.53			
9000	0.80	0.86	0.86	0.86	0.18	0.46	0.80	0.86	0.45			
9500	0.71	0.77	0.77	0.77	0.15	0.38	0.68	0.77	0.38			
10000	0.64	0.69	0.69	0.69	0.13	0.32	0.58	0.69	0.33			
10500	0.58	0.63	0.63	0.63	0.11	0.27	0.49	0.63	0.28			
11000	0.52	0.57	0.57	0.57	0.09	0.23	0.41	0.57	0.25			
11500	0.48	0.52	0.52	0.52	0.08	0.19	0.35	0.51	0.21			
12000	0.43	0.48	0.48	0.48	0.07	0.16	0.30	0.46	0.19			

Span	C/Z 200 - 19											
	Inward				Intward				Def'n L/150			
	0	1	2	3	0	1	2	3				
2500	16.56	16.63	16.63	16.63	16.63	16.63	16.63	16.63	27.83			
3000	11.03	11.55	11.55	11.55	11.04	11.55	11.55	11.55	16.11			
3500	7.82	8.48	8.48	8.48	7.26	8.48	8.48	8.48	10.14			
4000	5.81	6.50	6.50	6.50	4.85	6.50	6.50	6.50	6.79			
4500	4.48	5.13	5.13	5.13	3.28	5.13	5.13	5.13	4.77			
5000	3.55	4.16	4.16	4.16	2.24	4.15	4.16	4.16	3.48			
5500	2.88	3.44	3.44	3.44	1.59	3.25	3.44	3.44	2.61			
6000	2.38	2.89	2.89	2.89	1.15	2.57	2.89	2.89	2.01			
6500	2.00	2.46	2.46	2.46	0.85	2.03	2.46	2.46	1.58			
7000	1.70	2.12	2.12	2.12	0.65	1.62	2.12	2.12	1.27			
7500	1.47	1.85	1.85	1.85	0.50	1.29	1.82	1.85	1.03			
8000	1.27	1.62	1.62	1.62	0.40	1.04	1.55	1.62	0.85			
8500	1.12	1.44	1.44	1.44	0.32	0.83	1.31	1.44	0.71			
9000	0.99	1.28	1.28	1.28	0.26	0.67	1.12	1.28	0.60			
9500	0.88	1.15	1.15	1.15	0.22	0.55	0.96	1.15	0.51			
10000	0.79	1.04	1.04	1.04	0.18	0.46	0.82	1.04	0.44			
10500	0.71	0.94	0.94	0.94	0.15	0.38	0.70	0.92	0.38			
11000	0.64	0.86	0.86	0.86	0.13	0.32	0.60	0.81	0.33			
11500	0.58	0.79	0.79	0.79	0.11	0.27	0.52	0.72	0.29			
12000	0.53	0.72	0.72	0.72	0.10	0.23	0.45	0.64	0.25			

Span	C/Z 200 - 24											
	Inward				Intward				Def'n L/150			
	0	1	2	3	0	1	2	3				
2500	21.99	23.78	23.78	23.78	23.51	23.78	23.78	23.78	35.75			
3000	14.56	16.51	16.51	16.51	15.16	16.51	16.51	16.51	20.69			
3500	10.27	12.13	12.13	12.13	10.15	12.13	12.13	12.13	13.03			
4000	7.56	9.29	9.29	9.29	6.72	9.29	9.29	9.29	8.73			
4500	5.75	7.34	7.34	7.34	4.48	7.28	7.34	7.34	6.13			
5000	4.51	5.94	5.94	5.94	3.03	5.67	5.94	5.94	4.47			
5500	3.62	4.91	4.91	4.91	2.12	4.48	4.91	4.91	3.36			
6000	2.97	4.10	4.13	4.13	1.54	3.58	4.13	4.13	2.59			
6500	2.47	3.46	3.52	3.52	1.15	2.87	3.51	3.52	2.03			
7000	2.09	2.85	3.03	3.03	0.88	2.27	2.95	3.03	1.63			
7500	1.79	2.55	2.64	2.64	0.69	1.80	2.50	2.64	1.32			
8000	1.55	2.22	2.32	2.32	0.55	1.43	2.13	2.32	1.09			
8500	1.35	1.95	2.06	2.06	0.45	1.14	1.82	2.06	0.91			
9000	1.19	1.73	1.84	1.84	0.37	0.92	1.57	1.82	0.77			
9500	1.05	1.54	1.65	1.65	0.31	0.75	1.35	1.61	0.65			
10000	0.94	1.38	1.48	1.49	0.26	0.62	1.15	1.42	0.56			
10500	0.85	1.25	1.33	1.35	0.22	0.51	0.98	1.26	0.48			
11000	0.76	1.13	1.21	1.23	0.19	0.43	0.84	1.12	0.42			
11500	0.69	1.03	1.10	1.12	0.16	0.36	0.72	1.00	0.37			
12000	0.63	0.94	1.00	1.03	0.14	0.31	0.61	0.90	0.32			



SINGLE SPAN

Single Spans are simply supported at each end with the purlin.

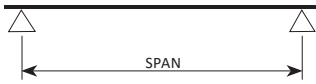

Span	C/Z 250 - 15											
	Inward				Intward				Def'n L/150			
	0	1	2	3	0	1	2	3				
3000	8.12	8.12	8.12	8.12	8.12	8.12	8.12	8.12	20.37			
3500	6.96	6.96	6.96	6.96	6.70	6.96	6.96	6.96	12.83			
4000	5.49	5.79	5.79	5.79	4.61	5.79	5.79	5.79	8.60			
4500	4.27	4.57	4.57	4.57	3.15	4.57	4.57	4.57	6.04			
5000	3.42	3.70	3.70	3.70	2.17	3.68	3.70	3.70	4.40			
5500	2.79	3.06	3.06	3.06	1.56	2.92	3.06	3.06	3.31			
6000	2.33	2.57	2.57	2.57	1.14	2.34	2.57	2.57	2.55			
6500	1.96	2.19	2.19	2.19	0.84	1.89	2.19	2.19	2.00			
7000	1.68	1.89	1.89	1.89	0.63	1.53	1.89	1.89	1.60			
7500	1.45	1.65	1.65	1.65	0.49	1.24	1.62	1.65	1.30			
8000	1.27	1.45	1.45	1.45	0.38	0.99	1.39	1.45	1.07			
8500	1.12	1.28	1.28	1.28	0.30	0.80	1.19	1.28	0.90			
9000	0.99	1.14	1.14	1.14	0.24	0.65	1.03	1.14	0.76			
9500	0.88	1.03	1.03	1.03	0.20	0.54	0.89	1.03	0.64			
10000	0.79	0.93	0.93	0.93	0.16	0.45	0.77	0.92	0.55			
10500	0.72	0.84	0.84	0.84	0.14	0.37	0.67	0.82	0.48			
11000	0.65	0.77	0.77	0.77	0.12	0.31	0.58	0.73	0.41			
11500	0.59	0.70	0.70	0.70	0.10	0.26	0.50	0.65	0.36			
12000	0.54	0.64	0.64	0.64	0.08	0.22	0.43	0.59	0.32			
12500	0.50	0.59	0.59	0.59	0.07	0.19	0.37	0.53	0.28			

Span	C/Z 250 - 15											
	Inward				Intward				Def'n L/150			
	0	1	2	3	0	1	2	3				
3000	14.68	14.72	14.72	14.72	14.72	14.72	14.72	14.72	26.83			
3500	10.43	10.82	10.82	10.82	9.78	10.82	10.82	10.82	16.90			
4000	7.71	8.28	8.28	8.28	6.46	8.28	8.28	8.28	11.32			
4500	5.91	6.54	6.54	6.54	4.31	6.54	6.54	6.54	7.95			
5000	4.67	5.30	5.30	5.30	2.92	5.30	5.30	5.30	5.80			
5500	3.78	4.38	4.38	4.38	2.06	4.37	4.38	4.38	4.35			
6000	3.12	3.68	3.68	3.68	1.48	3.47	3.68	3.68	3.35			
6500	2.61	3.14	3.14	3.14	1.09	2.74	3.14	3.14	2.64			
7000	2.22	2.70	2.70	2.70	0.83	2.17	2.70	2.70	2.11			
7500	1.90	2.36	2.36	2.36	0.64	1.71	2.36	2.36	1.72			
8000	1.65	2.07	2.07	2.07	0.50	1.37	2.07	2.07	1.42			
8500	1.45	1.83	1.83	1.83	0.40	1.09	1.78	1.83	1.18			
9000	1.28	1.64	1.64	1.64	0.33	0.88	1.51	1.64	0.99			
9500	1.13	1.47	1.47	1.47	0.27	0.72	1.29	1.47	0.85			
10000	1.01	1.33	1.33	1.33	0.22	0.59	1.10	1.33	0.72			
10500	0.91	1.20	1.20	1.20	0.19	0.49	0.94	1.20	0.63			
11000	0.82	1.10	1.10	1.10	0.16	0.41	0.80	1.10	0.54			
11500	0.75	1.00	1.00	1.00	0.14	0.34	0.68	0.98	0.48			
12000	0.68	0.92	0.92	0.92	0.12	0.29	0.58	0.87	0.42			
12500	0.62	0.85	0.85	0.85	0.10	0.25	0.50	0.77	0.37			

Span	C/Z 250 - 24											
	Inward				Intward				Def'n L/150			
	0	1	2	3	0	1	2	3				
3000	19.19	20.99	20.99	20.99	20.31	20.99	20.99	20.99	35.05			
3500	13.42	15.43	15.43	15.43	13.45	15.43	15.43	15.43	22.07			
4000	9.75	11.81	11.81	11.81	8.74	11.81	11.81	11.81	14.79			
4500	7.36	9.33	9.33	9.33	5.76	9.33	9.33	9.33	10.39			
5000	5.73	7.56	7.56	7.56	3.85	7.56	7.56	7.56	7.57			
5500	4.58	6.25	6.25	6.25	2.69	5.99	6.25	6.25	5.69			
6000	3.73	5.25	5.25	5.25	1.94	4.75	5.25	5.25	4.38			
6500	3.10	4.47	4.47	4.47	1.44	3.77	4.47	4.47	3.45			
7000	2.61	3.86	3.86	3.86	1.10	2.96	3.86	3.86	2.76			
7500	2.23	3.36	3.36	3.36	0.85	2.32	3.35	3.36	2.24			
8000	1.93	2.95	2.95	2.95	0.67	1.84	2.85	2.95	1.85			
8500	1.68	2.60	2.62	2.62	0.54	1.45	2.43	2.62	1.54			
9000	1.48	2.30	2.33	2.33	0.44	1.17	2.08	2.33	1.30			
9500	1.31	2.05	2.09	2.09	0.37	0.95	1.77	2.09	1.10			
10000	1.17	1.83	1.89	1.89	0.31	0.78	1.51	1.89	0.95			
10500	1.05	1.65	1.71	1.71	0.26	0.65	1.28	1.69	0.82			
11000	0.94	1.49	1.56	1.56	0.22	0.54	1.08	1.50	0.71			
11500	0.85	1.36	1.43	1.43	0.19	0.46	0.92	1.34	0.62			
12000	0.78	1.24	1.31	1.31	0.17	0.39	0.79	1.19	0.55			
12500	0.71	1.14	1.21	1.21	0.15	0.33	0.67	1.07	0.49			

Where strength matters



SINGLE SPAN

Single Spans are simply supported at each end with the purlin.

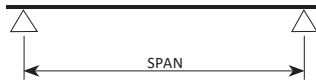

Where strength matters

Span	C/Z 300 - 24								
	Inward				Intward				Def'n L/150
	0	1	2	3	0	1	2	3	
4000	14.28	16.64	16.64	16.64	15.92	16.64	16.64	16.64	25.55
4500	10.64	13.15	13.15	13.15	11.48	13.14	13.15	13.15	17.95
5000	8.21	10.65	10.65	10.65	8.32	10.65	10.65	10.65	13.08
5500	6.50	8.80	8.80	8.80	6.13	8.80	8.80	8.80	9.3
6000	5.26	7.39	7.39	7.39	4.50	7.39	7.39	7.39	7.57
6500	4.34	6.30	6.30	6.30	3.31	6.30	6.30	6.30	5.96
7000	3.62	5.43	5.43	5.43	2.49	5.32	5.43	5.43	4.77
7500	3.06	4.73	4.73	4.73	1.91	4.42	4.73	4.73	3.88
8000	2.63	4.16	4.16	4.16	1.50	3.69	4.16	4.16	3.19
8500	2.28	3.68	3.68	3.68	1.19	3.08	3.68	3.68	2.66
9000	1.98	3.29	3.29	3.29	0.96	2.57	3.29	3.29	2.24
9500	1.74	2.92	2.95	2.95	0.79	2.17	2.95	2.95	1.91
10000	1.54	2.61	2.66	2.66	0.65	1.83	2.65	2.66	1.64
10500	1.38	2.34	2.41	2.41	0.54	1.53	2.33	2.41	1.41
11000	1.23	2.11	2.20	2.20	0.46	1.29	2.06	2.20	1.23
11500	1.11	1.91	2.01	2.01	0.39	1.08	1.82	2.01	1.08
12000	1.01	1.73	1.85	1.85	0.33	0.92	1.61	1.85	0.95
12500	0.92	1.58	1.70	1.70	0.29	0.78	1.42	1.70	0.84
13000	0.84	1.45	1.58	1.58	0.25	0.67	1.26	1.58	0.74
13500	0.77	1.33	1.46	1.46	0.22	0.58	1.12	1.46	0.67
14000	0.71	1.23	1.36	1.36	0.19	0.50	0.99	1.33	0.60
14500	0.65	1.14	1.27	1.27	0.17	0.44	0.89	1.22	0.54
15000	0.61	1.06	1.18	1.18	0.15	0.39	0.79	1.11	0.49

Span	C/Z 300 - 30								
	Inward				Intward				Def'n L/150
	0	1	2	3	0	1	2	3	
4000	18.85	23.57	23.57	23.57	21.85	23.57	23.57	23.57	32.90
4500	13.69	18.63	18.63	18.63	16.00	18.62	18.63	18.63	23.11
5000	10.17	15.09	15.09	15.09	11.65	15.09	15.09	15.09	16.85
5500	7.79	12.47	12.47	12.47	8.24	12.47	12.47	12.47	12.66
6000	6.14	10.48	10.48	10.48	5.90	10.48	10.48	10.48	9.75
6500	4.96	8.93	8.93	8.93	4.35	8.71	8.93	8.93	7.67
7000	4.09	7.61	7.70	7.70	3.28	7.27	7.70	7.70	6.14
7500	3.43	6.53	6.71	6.71	2.53	6.12	6.71	6.71	4.99
8000	2.92	5.65	5.89	5.89	1.99	5.16	5.89	5.89	4.11
8500	2.51	4.94	5.22	5.22	1.59	4.33	5.22	5.22	3.43
9000	2.18	4.34	4.66	4.66	1.29	3.63	4.64	4.66	2.89
9500	1.91	3.85	4.18	4.18	1.06	3.00	4.09	4.18	2.46
10000	1.69	3.43	3.77	3.77	0.88	2.47	3.61	3.77	2.11
10500	1.51	3.07	3.42	3.42	0.74	2.04	3.20	3.42	1.82
11000	1.35	2.77	3.11	3.12	0.62	1.71	2.85	3.12	1.58
11500	1.22	2.50	2.82	2.85	0.53	1.44	2.54	2.85	1.39
12000	1.10	2.26	2.57	2.62	0.46	1.22	2.25	2.62	1.22
12500	1.00	2.06	2.34	2.41	0.40	1.04	2.00	2.39	1.08
13000	0.92	1.88	2.15	2.23	0.35	0.90	1.78	2.18	0.96
13500	0.84	1.72	1.98	2.07	0.31	0.78	1.57	1.99	0.86
14000	0.77	1.58	1.82	1.92	0.27	0.68	1.38	1.82	0.77
14500	0.71	1.46	1.69	1.79	0.24	0.59	1.20	1.67	0.69
15000	0.66	1.35	1.56	1.68	0.21	0.52	1.06	1.53	0.62



SINGLE SPAN

Single Spans are simply supported at each end with the purlin.

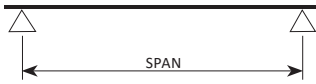

Span	C/Z 300 - 24								
	Inward				Intward				Def'n L/150
	0	1	2	3	0	1	2	3	
4000	17.94	17.94	17.94	17.94	17.94	17.94	17.94	17.94	41.08
4500	14.48	15.95	15.94	15.94	15.94	15.94	15.95	15.95	28.85
5000	11.27	13.19	13.19	13.19	12.58	13.19	13.19	13.19	21.03
5500	8.95	10.90	10.90	10.90	9.93	10.90	10.90	10.90	15.80
6000	7.07	9.16	9.16	9.16	7.91	9.16	9.16	9.16	12.17
6500	5.70	7.81	7.81	7.81	6.28	7.81	7.81	7.81	9.57
7000	4.68	6.73	6.73	6.73	4.84	6.73	6.73	6.73	7.66
7500	3.91	5.86	5.86	5.86	3.79	5.86	5.86	5.86	6.23
8000	3.32	5.15	5.15	5.15	3.01	5.14	5.15	5.15	5.14
8500	2.85	4.57	4.57	4.57	2.43	4.46	4.57	4.57	4.28
9000	2.47	4.07	4.07	4.07	2.01	3.89	4.07	4.07	3.61
9500	2.16	3.62	3.65	3.65	1.66	3.41	3.65	3.65	3.07
10000	1.91	3.23	3.30	3.30	1.38	3.00	3.30	3.30	2.63
10500	1.70	2.90	2.99	2.99	1.15	2.64	2.99	2.99	2.27
11000	1.52	2.62	2.73	2.73	0.96	2.33	2.73	2.73	1.98
11500	1.37	2.38	2.49	2.49	0.81	2.06	2.49	2.49	1.73
12000	1.24	2.17	2.29	2.29	0.69	1.78	2.27	2.29	1.52
12500	1.12	1.98	2.11	2.11	0.59	1.54	2.06	2.11	1.35
13000	1.03	1.81	1.95	1.95	0.51	1.34	1.88	1.95	1.20
13500	0.94	1.67	1.81	1.81	0.44	1.17	1.72	1.81	1.07
14000	0.87	1.54	1.68	1.68	0.39	1.02	1.57	1.68	0.96
14500	0.80	1.43	1.57	1.57	0.34	0.90	1.44	1.57	0.86
15000	0.74	1.32	1.46	1.47	0.30	0.80	1.32	1.47	0.78

Span	C/Z 300 - 30								
	Inward				Intward				Def'n L/150
	0	1	2	3	0	1	2	3	
4000	25.72	28.62	28.62	28.62	28.62	28.62	28.62	28.62	53.16
4500	18.86	22.61	22.61	22.61	22.61	22.61	22.61	22.61	37.33
5000	14.13	18.32	18.32	18.32	17.68	18.32	18.32	18.32	27.22
5500	10.79	15.14	15.14	15.14	13.64	15.14	15.14	15.14	20.45
6000	8.50	12.72	12.72	12.72	10.56	12.72	12.72	12.72	15.75
6500	6.86	10.84	10.84	10.84	8.15	10.84	10.84	10.84	12.39
7000	5.65	9.35	9.35	9.35	6.33	9.35	9.35	9.35	9.92
7500	4.71	8.14	8.14	8.14	5.02	8.14	8.14	8.14	8.06
8000	3.96	7.16	7.16	7.16	4.00	7.16	7.16	7.16	6.65
8500	3.38	6.34	6.34	6.34	3.22	6.34	6.34	6.34	5.54
9000	2.92	5.65	5.65	5.65	2.63	5.49	5.65	5.65	4.67
9500	2.55	5.06	5.07	5.07	2.14	4.75	5.07	5.07	3.97
10000	2.24	4.49	4.58	4.58	1.76	4.12	4.58	4.58	3.40
10500	1.99	4.00	4.15	4.15	1.46	3.57	4.15	4.15	2.94
11000	1.78	3.58	3.78	3.78	1.23	3.10	3.78	3.78	2.56
11500	1.60	3.22	3.46	3.46	1.04	2.69	3.46	3.46	2.24
12000	1.44	2.91	3.18	3.18	0.89	2.32	3.18	3.18	1.97
12500	1.30	2.64	2.93	2.93	0.76	2.02	2.93	2.93	1.74
13000	1.18	2.40	2.71	2.71	0.66	1.77	2.66	2.71	1.55
13500	1.08	2.19	2.51	2.51	0.58	1.56	2.41	2.51	1.38
14000	0.99	2.01	2.34	2.34	0.50	1.37	2.18	2.34	1.24
14500	0.91	1.84	2.18	2.18	0.44	1.21	1.98	2.18	1.12
15000	0.84	1.70	2.04	2.04	0.39	1.07	1.80	2.04	1.01

Where strength matters



NOTE: All gauges of section C/Z 350 require M16 grade 4.6 bolts unless indicated otherwise. Values shaded require M16 grade 8.8 bolts.

SINGLE SPAN

Single Spans are simply supported at each end with the purlin.

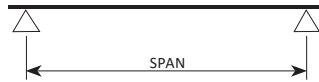

Where strength matters



Span	C/Z 400 - 24									
	Inward				Intward				Def'n L/150	
	0	1	2	3	0	1	2	3		
4000	15.61	15.61	15.61	15.61	15.61	15.61	15.61	15.61	55.10	
4500	13.88	13.88	13.88	13.87	13.88	13.88	13.88	13.87	38.70	
5000	12.41	12.49	12.49	12.49	12.49	12.49	12.49	12.49	28.21	
5500	9.81	11.35	11.35	11.35	11.05	11.35	11.35	11.35	21.19	
6000	7.91	10.39	10.39	10.39	8.77	10.39	10.39	10.39	16.33	
6500	6.50	8.85	8.85	8.85	6.98	8.85	8.85	8.85	12.84	
7000	5.39	7.63	7.63	7.63	5.59	7.63	7.63	7.63	10.28	
7500	4.50	6.65	6.65	6.65	4.41	6.65	6.65	6.65	8.36	
8000	3.81	5.84	5.84	5.84	3.50	5.76	5.84	5.84	6.89	
8500	3.27	5.15	5.18	5.18	2.82	4.99	5.18	5.18	5.74	
9000	2.83	4.55	4.62	4.62	2.32	4.35	4.62	4.62	4.84	
9500	2.48	4.04	4.14	4.14	1.92	3.80	4.14	4.14	4.11	
10000	2.19	3.61	3.74	3.74	1.59	3.33	3.74	3.74	3.53	
10500	1.94	3.24	3.39	3.39	1.33	2.93	3.39	3.39	3.05	
11000	1.74	2.92	3.09	3.09	1.11	2.58	3.09	3.09	2.65	
11500	1.56	2.65	2.83	2.83	0.94	2.27	2.81	2.83	2.32	
12000	1.41	2.41	2.60	2.60	0.80	2.00	2.54	2.60	2.04	
12500	1.29	2.20	2.39	2.39	0.68	1.77	2.31	2.39	1.81	
13000	1.17	2.02	2.21	2.21	0.59	1.55	2.10	2.21	1.61	
13500	1.08	1.85	2.05	2.05	0.51	1.36	1.91	2.05	1.43	
14000	0.99	1.71	1.90	1.91	0.44	1.19	1.75	1.91	1.29	
14500	0.92	1.58	1.76	1.78	0.39	1.05	1.60	1.78	1.16	
15000	0.85	1.47	1.63	1.66	0.34	0.93	1.46	1.66	1.05	
15000	0.79	1.36	1.52	1.56	0.30	0.83	1.34	1.55	0.95	
16000	0.74	1.27	1.42	1.46	0.27	0.74	1.23	1.44	0.86	

Span	C/Z 400 - 24									
	Inward				Intward				Def'n L/150	
	0	1	2	3	0	1	2	3		
4000	30.58	30.58	30.58	30.58	30.58	30.58	30.58	30.58	71.70	
4500	22.32	26.14	26.14	26.14	26.14	26.14	26.14	26.14	50.36	
5000	16.61	21.17	21.17	21.17	20.70	21.17	21.17	21.17	36.71	
5500	12.64	17.50	17.50	17.50	16.34	17.50	17.50	17.50	27.58	
6000	9.93	14.70	14.70	14.70	12.60	14.70	14.70	14.70	21.24	
6500	8.00	12.53	12.53	12.53	9.69	12.53	12.53	12.53	16.71	
7000	6.56	10.80	10.80	10.80	7.50	10.80	10.80	10.80	13.38	
7500	5.43	9.41	9.41	9.41	5.94	9.41	9.41	9.41	10.88	
8000	4.57	8.27	8.27	8.27	4.71	8.27	8.27	8.27	8.96	
8500	3.90	7.33	7.33	7.33	3.78	7.33	7.33	7.33	7.47	
9000	3.36	6.53	6.53	6.53	3.07	6.41	6.53	6.53	6.29	
9500	2.93	5.84	5.87	5.87	2.50	5.62	5.87	5.87	5.35	
10000	2.58	5.21	5.29	5.29	2.05	4.93	5.29	5.29	4.59	
10500	2.28	4.67	4.80	4.80	1.70	4.27	4.80	4.80	3.96	
11000	2.03	4.21	4.37	4.37	1.43	3.70	4.37	4.37	3.45	
11500	1.82	3.81	4.00	4.00	1.21	3.19	4.00	4.00	3.02	
12000	1.64	3.46	3.68	3.68	1.03	2.75	3.68	3.68	2.66	
12500	1.48	3.14	3.39	3.39	0.88	2.39	3.39	3.39	2.35	
13000	1.34	2.85	3.13	3.13	0.76	2.09	3.09	3.13	2.09	
13500	1.23	2.60	2.90	2.90	0.66	1.84	2.83	2.90	1.87	
14000	1.12	2.37	2.70	2.70	0.58	1.62	2.58	2.70	1.67	
14500	1.03	2.18	2.52	2.52	0.51	1.42	2.37	2.52	1.51	
15000	0.95	2.00	2.35	2.35	0.45	1.25	2.15	2.35	1.36	
15000	0.88	1.85	2.20	2.20	0.40	1.11	1.95	2.20	1.23	
16000	0.82	1.71	2.05	2.07	0.36	0.99	1.77	2.07	1.12	

NOTE: All gauges of section C/Z 400 require M16 grade 4.6 bolts unless indicated otherwise. Values shaded require M16 grade 8.8 bolts.

CONTINUOUS SPAN

Two continuous spans are continuous over two bays of equal span, supported at each end of the purlin and over a central support.

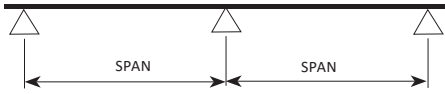

Span	C/Z 100 - 10								
	Inward				Intward				Def'n L/150
	0	1	2	3	0	1	2	3	
1500	7.16	7.16	7.16	7.16	7.16	7.16	7.16	7.16	24.39
2000	4.50	4.50	4.50	4.50	4.50	4.50	4.50	4.50	10.29
2500	2.88	2.88	2.88	2.88	2.88	2.88	2.88	2.88	5.27
3000	2.00	2.00	2.00	2.00	2.00	2.00	2.00	2.00	3.05
3500	1.47	1.47	1.47	1.47	1.47	1.47	1.47	1.47	1.92
4000	1.13	1.13	1.13	1.13	1.07	1.13	1.13	1.13	1.29
4500	0.89	0.89	0.89	0.89	0.77	0.89	0.89	0.89	0.90
5000	0.72	0.72	0.72	0.72	0.56	0.71	0.72	0.72	0.66
5500	0.58	0.60	0.60	0.60	0.41	0.55	0.60	0.60	0.50
6000	0.48	0.50	0.50	0.50	0.30	0.43	0.50	0.50	0.38
6500	0.40	0.43	0.43	0.43	0.23	0.33	0.43	0.43	0.30
7000	0.33	0.37	0.37	0.37	0.18	0.26	0.36	0.37	0.24
7500	0.28	0.32	0.32	0.32	0.14	0.20	0.30	0.32	0.20
8000	0.24	0.28	0.28	0.28	0.12	0.16	0.25	0.28	0.16

Span	C/Z 100 - 12								
	Inward				Intward				Def'n L/150
	0	1	2	3	0	1	2	3	
1500	9.59	9.59	9.59	9.59	9.59	9.59	9.59	9.59	29.48
2000	5.46	5.46	5.46	5.46	5.46	5.46	5.46	5.46	12.44
2500	3.50	3.50	3.50	3.50	3.50	3.50	3.50	3.50	6.37
3000	2.43	2.43	2.43	2.43	2.43	2.43	2.43	2.43	3.68
3500	1.78	1.78	1.78	1.78	1.75	1.78	1.78	1.78	2.32
4000	1.35	1.37	1.37	1.37	1.26	1.37	1.37	1.37	1.55
4500	1.04	1.08	1.08	1.08	0.92	1.08	1.08	1.08	1.09
5000	0.83	0.87	0.87	0.87	0.68	0.83	0.87	0.87	0.80
5500	0.67	0.72	0.72	0.72	0.51	0.65	0.72	0.72	0.60
6000	0.55	0.61	0.61	0.61	0.39	0.51	0.61	0.61	0.46
6500	0.46	0.52	0.52	0.52	0.30	0.41	0.50	0.52	0.36
7000	0.38	0.45	0.45	0.45	0.24	0.32	0.42	0.45	0.29
7500	0.33	0.39	0.39	0.39	0.19	0.26	0.35	0.38	0.24
8000	0.28	0.34	0.34	0.34	0.15	0.21	0.29	0.33	0.19

Span	C/Z 100 - 15								
	Inward				Intward				Def'n L/150
	0	1	2	3	0	1	2	3	
1500	12.53	12.53	12.53	12.53	12.53	12.53	12.53	12.53	37.53
2000	7.04	7.11	7.11	7.11	7.11	7.11	7.11	7.11	15.83
2500	4.42	4.55	4.55	4.55	4.55	4.55	4.55	4.55	8.11
3000	3.02	3.16	3.16	3.16	3.12	3.16	3.16	3.16	4.69
3500	2.18	2.32	2.32	2.32	2.20	2.32	2.32	2.32	2.95
4000	1.65	1.78	1.78	1.78	1.60	1.76	1.78	1.78	1.98
4500	1.28	1.41	1.41	1.41	1.20	1.35	1.41	1.41	1.39
5000	1.02	1.14	1.14	1.14	0.92	1.05	1.14	1.14	1.01
5500	0.83	0.94	0.94	0.94	0.71	0.84	0.93	0.94	0.76
6000	0.69	0.79	0.79	0.79	0.54	0.67	0.77	0.79	0.59
6500	0.57	0.67	0.67	0.67	0.42	0.55	0.64	0.67	0.46
7000	0.49	0.58	0.58	0.58	0.33	0.45	0.53	0.57	0.37
7500	0.41	0.51	0.51	0.51	0.26	0.36	0.45	0.48	0.30
8000	0.36	0.44	0.45	0.45	0.21	0.29	0.38	0.42	0.25

Span	C/Z 100 - 19								
	Inward				Intward				Def'n L/150
	0	1	2	3	0	1	2	3	
1500	17.48	17.50	17.50	17.50	17.50	17.50	17.50	17.50	48.35
2000	9.48	9.91	9.91	9.90	9.90	9.90	9.91	9.91	20.40
2500	5.90	6.34	6.34	6.34	6.34	6.34	6.34	6.34	10.44
3000	4.01	4.40	4.40	4.40	4.29	4.40	4.40	4.40	6.04
3500	2.89	3.23	3.23	3.23	3.00	3.23	3.23	3.23	3.81
4000	2.17	2.48	2.48	2.48	2.18	2.43	2.48	2.48	2.55
4500	1.68	1.96	1.96	1.96	1.63	1.86	1.96	1.96	1.79
5000	1.34	1.59	1.59	1.59	1.24	1.44	1.59	1.59	1.31
5500	1.09	1.31	1.31	1.31	0.96	1.14	1.29	1.31	0.98
6000	0.90	1.10	1.10	1.10	0.76	0.92	1.06	1.10	0.76
6500	0.75	0.94	0.94	0.94	0.60	0.74	0.87	0.93	0.59
7000	0.63	0.81	0.81	0.81	0.48	0.61	0.73	0.78	0.48
7500	0.54	0.70	0.70	0.70	0.38	0.50	0.62	0.66	0.39
8000	0.47	0.60	0.62	0.62	0.31	0.42	0.52	0.57	0.32

Span	C/Z 100 - 24								
	Inward				Intward				Def'n L/150
	0	1	2	3	0	1	2	3	
1500	22.03	22.26	22.26	22.26	22.26	22.26	22.26	22.26	60.38
2000	11.95	12.85	12.85	12.85	12.85	12.85	12.85	12.85	25.47
2500	7.45	8.23	8.23	8.23	8.17	8.23	8.23	8.23	13.04
3000	5.07	5.71	5.71	5.71	5.47	5.71	5.71	5.71	7.55
3500	3.66	4.20	4.20	4.20	3.87	4.17	4.20	4.20	4.75
4000	2.75	3.21	3.21	3.21	2.84	3.11	3.21	3.21	3.18
4500	2.13	2.54	2.54	2.54	2.14	2.39	2.54	2.54	2.24
5000	1.70	2.06	2.06	2.06	1.64	1.87	2.03	2.06	1.63
5500	1.38	1.70	1.70	1.70	1.28	1.50	1.65	1.70	1.23
6000	1.14	1.42	1.43	1.43	1.02	1.21	1.36	1.41	0.94
6500	0.96	1.20	1.22	1.22	0.82	0.99	1.13	1.18	0.74
7000	0.81	1.03	1.05	1.05	0.67	0.81	0.95	1.00	0.59
7500	0.69	0.88	0.91	0.91	0.55	0.68	0.81	0.86	0.48
8000	0.60	0.77	0.79	0.80	0.45	0.57	0.69	0.74	0.40

NOTE: All gauges of section C/Z 100 require M12 grade 4.6 bolts unless indicated otherwise. Values shaded require M12 grade 8.8 bolts.

Where strength matters



CONTINUOUS SPAN

Two continuous spans are continuous over two bays of equal span, supported at each end of the purlin and over a central support.

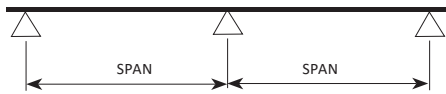

Where strength matters

Span	C/Z 150 - 10											
	Inward				Intward				Def'n L/150			
	0	1	2	3	0	1	2	3				
2000	4.35	4.35	4.35	4.35	4.35	4.35	4.35	4.35	28.91			
2500	3.27	3.27	3.27	3.27	3.27	3.27	3.27	3.27	14.80			
3000	2.55	2.55	2.55	2.55	2.55	2.55	2.55	2.55	8.57			
3500	2.04	2.04	2.04	2.04	2.04	2.04	2.04	2.04	5.40			
4000	1.67	1.67	1.67	1.67	1.67	1.67	1.67	1.67	3.61			
4500	1.38	1.38	1.38	1.38	1.38	1.38	1.38	1.38	2.54			
5000	1.16	1.16	1.16	1.16	1.14	1.16	1.16	1.16	1.85			
5500	0.97	0.99	0.99	0.99	0.89	0.99	0.99	0.99	1.39			
6000	0.81	0.84	0.84	0.84	0.69	0.83	0.84	0.84	1.07			
6500	0.68	0.72	0.72	0.72	0.55	0.68	0.72	0.72	0.84			
7000	0.57	0.62	0.62	0.62	0.44	0.56	0.62	0.62	0.67			
7500	0.49	0.54	0.54	0.54	0.34	0.46	0.54	0.54	0.55			
8000	0.42	0.47	0.47	0.47	0.27	0.39	0.47	0.47	0.45			
8500	0.37	0.42	0.42	0.42	0.22	0.32	0.41	0.42	0.38			
9000	0.32	0.37	0.37	0.37	0.18	0.27	0.35	0.37	0.32			
9500	0.28	0.34	0.34	0.34	0.15	0.22	0.31	0.34	0.27			
10000	0.24	0.30	0.30	0.30	0.13	0.19	0.27	0.30	0.23			

Span	C/Z 150 - 12											
	Inward				Intward				Def'n L/150			
	0	1	2	3	0	1	2	3				
2000	6.85	6.85	6.85	6.85	6.85	6.85	6.85	6.85	35.92			
2500	4.99	4.99	4.99	4.99	4.99	4.99	4.99	4.99	18.39			
3000	3.78	3.78	3.78	3.78	3.78	3.78	3.78	3.78	10.64			
3500	2.95	2.95	2.95	2.95	2.95	2.95	2.95	2.95	6.70			
4000	2.35	2.35	2.35	2.35	2.35	2.35	2.35	2.35	4.49			
4500	1.86	1.86	1.86	1.86	1.86	1.86	1.86	1.86	3.15			
5000	1.51	1.51	1.51	1.51	1.48	1.51	1.51	1.51	2.30			
5500	1.23	1.25	1.25	1.25	1.17	1.25	1.25	1.25	1.73			
6000	1.02	1.05	1.05	1.05	0.91	1.05	1.05	1.05	1.33			
6500	0.86	0.89	0.89	0.89	0.70	0.89	0.89	0.89	1.05			
7000	0.73	0.77	0.77	0.77	0.55	0.74	0.77	0.77	0.84			
7500	0.62	0.67	0.67	0.67	0.43	0.61	0.67	0.67	0.68			
8000	0.53	0.59	0.59	0.59	0.35	0.50	0.59	0.59	0.56			
8500	0.46	0.52	0.52	0.52	0.28	0.41	0.52	0.52	0.47			
9000	0.40	0.47	0.47	0.47	0.23	0.34	0.46	0.47	0.39			
9500	0.35	0.42	0.42	0.42	0.19	0.28	0.40	0.42	0.34			
10000	0.30	0.38	0.38	0.38	0.17	0.23	0.35	0.38	0.29			

Span	C/Z 150 - 15											
	Inward				Intward				Def'n L/150			
	0	1	2	3	0	1	2	3				
2000	11.09	11.09	11.09	11.09	11.09	11.09	11.09	11.09	46.64			
2500	7.72	7.72	7.72	7.72	7.72	7.72	7.72	7.72	23.88			
3000	5.51	5.51	5.51	5.51	5.51	5.51	5.51	5.51	13.82			
3500	4.00	4.05	4.05	4.05	4.05	4.05	4.05	4.05	8.70			
4000	3.00	3.10	3.10	3.10	3.10	3.10	3.10	3.10	5.83			
4500	2.33	2.45	2.45	2.45	2.44	2.45	2.45	2.45	4.09			
5000	1.85	1.98	1.98	1.98	1.88	1.98	1.98	1.98	2.99			
5500	1.50	1.64	1.64	1.64	1.47	1.64	1.64	1.64	2.24			
6000	1.24	1.38	1.38	1.38	1.16	1.38	1.38	1.38	1.73			
6500	1.04	1.17	1.17	1.17	0.92	1.14	1.17	1.17	1.36			
7000	0.88	1.01	1.01	1.01	0.74	0.94	1.01	1.01	1.09			
7500	0.75	0.88	0.88	0.88	0.59	0.78	0.88	0.88	0.88			
8000	0.65	0.78	0.78	0.78	0.48	0.65	0.78	0.78	0.73			
8500	0.56	0.69	0.69	0.69	0.39	0.55	0.68	0.69	0.61			
9000	0.49	0.61	0.61	0.61	0.32	0.46	0.59	0.61	0.51			
9500	0.43	0.55	0.55	0.55	0.27	0.38	0.51	0.55	0.44			
10000	0.38	0.50	0.50	0.50	0.23	0.32	0.45	0.49	0.37			

Span	C/Z 150 - 19											
	Inward				Intward				Def'n L/150			
	0	1	2	3	0	1	2	3				
2000	15.76	15.76	15.76	15.76	15.76	15.76	15.76	15.76	59.68			
2500	10.77	11.20	11.20	11.20	11.20	11.20	11.20	11.20	30.56			
3000	7.27	7.78	7.78	7.78	7.78	7.78	7.78	7.78	17.68			
3500	5.21	5.72	5.72	5.72	5.72	5.72	5.72	5.72	11.14			
4000	3.91	4.38	4.38	4.38	4.32	4.38	4.38	4.38	7.46			
4500	3.03	3.46	3.46	3.46	3.28	3.46	3.46	3.46	5.24			
5000	2.41	2.80	2.80	2.80	2.55	2.80	2.80	2.80	3.82			
5500	1.95	2.32	2.32	2.32	2.01	2.29	2.32	2.32	2.87			
6000	1.61	1.95	1.95	1.95	1.60	1.87	1.95	1.95	2.21			
6500	1.35	1.66	1.66	1.66	1.29	1.54	1.66	1.66	1.74			
7000	1.14	1.43	1.43	1.43	1.03	1.28	1.43	1.43	1.39			
7500	0.98	1.25	1.25	1.25	0.82	1.07	1.24	1.25	1.13			
8000	0.85	1.09	1.09	1.09	0.66	0.91	1.06	1.09	0.93			
8500	0.73	0.97	0.97	0.97	0.54	0.77	0.92	0.97	0.78			
9000	0.64	0.86	0.86	0.86	0.45	0.65	0.80	0.86	0.66			
9500	0.56	0.78	0.78	0.78	0.37	0.54	0.70	0.75	0.56			
10000	0.49	0.70	0.70	0.70	0.31	0.45	0.62	0.67	0.48			

Span	C/Z 150 - 24											
	Inward				Intward				Def'n L/150			
	0	1	2	3	0	1	2	3				
2000	19.91	19.90	19.91	19.91	19.91	19.91	19.91	19.91	76.97			
2500	14.35	15.71	15.71	15.71	15.71	15.71	15.71	15.71	39.41			
3000	9.56	10.91	10.91	10.91	10.91	10.91	10.91	10.91	22.81			
3500	6.79	8.01	8.01	8.01	8.01	8.01	8.01	8.01	14.36			
4000	5.05	6.14	6.14	6.14	5.92	6.14	6.14	6.14	9.62			
4500	3.88	4.85	4.85	4.85	4.48	4.85	4.85	4.85	6.76			
5000	3.07	3.93	3.93	3.93	3.46	3.92	3.93	3.93	4.93			
5500	2.49	3.25	3.25	3.25	2.71	3.15	3.25	3.25	3.70			
6000	2.05	2.73	2.73	2.73	2.16	2.56	2.73	2.73	2.85			
6500	1.71	2.32	2.32	2.32	1.74	2.11	2.32	2.32	2.24			
7000	1.45	2.00	2.00	2.00	1.41	1.75	2.00	2.00	1.80			
7500	1.24	1.75	1.75	1.75	1.14	1.46	1.70	1.75	1.46			
8000	1.07	1.53	1.53	1.53	0.92	1.23	1.46	1.53	1.20			
8500	0.92	1.35	1.36	1.36	0.75	1.04	1.26	1.35	1.00			
9000	0.80	1.19	1.21	1.21	0.62	0.89	1.10	1.18	0.85			
9500	0.70	1.06	1.09	1.09	0.52	0.76	0.96	1.04	0.72			
10000	0.62	0.95	0.98	0.98	0.44	0.64	0.84	0.92	0.62			

NOTE: All gauges of section C/Z 150 require M12 grade 4.6 bolts unless indicated otherwise. Values shaded require M12 grade 8.8 bolts.



CONTINUOUS SPAN

Two continuous spans are continuous over two bays of equal span, supported at each end of the purlin and over a central support.

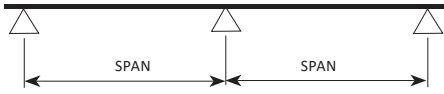

Span	C/Z 200 - 12								
	Inward				Intward				Def'n L/150
	0	1	2	3	0	1	2	3	
2500	4.48	4.48	4.48	4.48	4.48	4.48	4.48	4.48	38.26
3000	3.57	3.57	3.57	3.58	3.57	3.57	3.57	3.57	22.14
3500	2.92	2.92	2.92	2.92	2.92	2.92	2.92	2.92	13.94
4000	2.43	2.43	2.43	2.43	2.43	2.43	2.43	2.43	9.34
4500	2.05	2.05	2.05	2.05	2.05	2.05	2.05	2.05	6.56
5000	1.75	1.75	1.75	1.75	1.75	1.75	1.75	1.75	4.78
5500	1.51	1.51	1.52	1.51	1.51	1.52	1.52	1.52	3.59
6000	1.32	1.32	1.32	1.32	1.32	1.32	1.32	1.32	2.77
6500	1.13	1.16	1.16	1.16	1.10	1.16	1.16	1.16	2.18
7000	0.96	1.02	1.02	1.02	0.90	1.02	1.02	1.02	1.74
7500	0.83	0.91	0.91	0.91	0.73	0.89	0.91	0.91	1.42
8000	0.71	0.81	0.81	0.81	0.60	0.76	0.81	0.81	1.17
8500	0.62	0.72	0.72	0.72	0.50	0.65	0.72	0.72	0.97
9000	0.55	0.64	0.64	0.64	0.42	0.56	0.64	0.64	0.82
9500	0.48	0.58	0.58	0.58	0.35	0.48	0.58	0.58	0.70
10000	0.43	0.52	0.52	0.52	0.29	0.41	0.51	0.52	0.60
10500	0.38	0.47	0.47	0.47	0.25	0.35	0.45	0.47	0.52
11000	0.34	0.43	0.43	0.43	0.21	0.31	0.40	0.43	0.45
11500	0.30	0.39	0.39	0.39	0.18	0.27	0.36	0.39	0.39
12000	0.27	0.36	0.36	0.36	0.16	0.23	0.32	0.35	0.35

Span	C/Z 200 - 15								
	Inward				Intward				Def'n L/150
	0	1	2	3	0	1	2	3	
2500	7.94	7.94	7.94	7.94	7.93	7.94	7.94	7.94	50.27
3000	6.15	6.15	6.15	6.15	6.15	6.15	6.15	6.15	29.09
3500	4.89	4.89	4.89	4.90	4.89	4.89	4.89	4.89	18.32
4000	3.98	3.98	3.98	3.98	3.98	3.98	3.98	3.98	12.27
4500	3.29	3.29	3.29	3.29	3.29	3.29	3.29	3.29	8.62
5000	2.72	2.76	2.76	2.76	2.76	2.76	2.76	2.76	6.28
5500	2.22	2.29	2.29	2.29	2.29	2.29	2.29	2.29	4.72
6000	1.84	1.93	1.93	1.93	1.91	1.93	1.93	1.93	3.64
6500	1.55	1.64	1.64	1.64	1.57	1.64	1.64	1.64	2.86
7000	1.32	1.41	1.41	1.41	1.29	1.41	1.41	1.41	2.29
7500	1.13	1.23	1.23	1.23	1.05	1.23	1.23	1.23	1.86
8000	0.97	1.08	1.08	1.08	0.85	1.08	1.08	1.08	1.53
8500	0.84	0.96	0.96	0.96	0.69	0.93	0.96	0.96	1.28
9000	0.74	0.86	0.86	0.86	0.57	0.80	0.86	0.86	1.08
9500	0.65	0.77	0.77	0.77	0.47	0.69	0.77	0.77	0.92
10000	0.57	0.69	0.69	0.69	0.40	0.59	0.69	0.69	0.79
10500	0.50	0.63	0.63	0.63	0.34	0.50	0.63	0.63	0.68
11000	0.45	0.57	0.57	0.57	0.29	0.43	0.57	0.57	0.59
11500	0.40	0.52	0.52	0.52	0.25	0.36	0.51	0.52	0.52
12000	0.35	0.48	0.48	0.48	0.22	0.31	0.46	0.48	0.46

Span	C/Z 200 - 19								
	Inward				Intward				Def'n L/150
	0	1	2	3	0	1	2	3	
2500	12.61	12.61	12.61	12.61	12.61	12.61	12.61	12.61	61.11
3000	10.51	10.51	10.51	10.51	10.51	10.51	10.51	10.51	38.84
3500	8.10	8.33	8.33	8.33	8.33	8.33	8.33	8.33	24.46
4000	6.00	6.50	6.50	6.50	6.50	6.50	6.50	6.50	16.38
4500	4.61	5.13	5.13	5.13	5.13	5.13	5.13	5.13	11.51
5000	3.63	4.16	4.16	4.16	4.16	4.16	4.16	4.16	8.39
5500	2.93	3.44	3.44	3.44	3.40	3.44	3.44	3.44	6.30
6000	2.40	2.89	2.89	2.89	2.73	2.89	2.89	2.89	4.85
6500	2.00	2.46	2.46	2.46	2.21	2.46	2.46	2.46	3.82
7000	1.69	2.12	2.12	2.12	1.80	2.12	2.12	2.12	3.06
7500	1.44	1.85	1.85	1.85	1.48	1.83	1.85	1.85	2.49
8000	1.24	1.62	1.62	1.62	1.22	1.56	1.62	1.62	2.05
8500	1.08	1.44	1.44	1.44	1.00	1.33	1.44	1.44	1.71
9000	0.94	1.28	1.28	1.28	0.84	1.14	1.28	1.28	1.44
9500	0.83	1.15	1.15	1.15	0.70	0.98	1.15	1.15	1.22
10000	0.73	1.04	1.04	1.04	0.58	0.84	1.04	1.04	1.05
10500	0.65	0.94	0.94	0.94	0.49	0.72	0.93	0.94	0.91
11000	0.58	0.86	0.86	0.86	0.42	0.62	0.83	0.86	0.79
11500	0.52	0.79	0.79	0.79	0.36	0.54	0.73	0.79	0.69
12000	0.46	0.72	0.72	0.72	0.31	0.47	0.66	0.72	0.61

Span	C/Z 200 - 24								
	Inward				Intward				Def'n L/150
	0	1	2	3	0	1	2	3	
2500	15.93	15.93	15.93	15.93	15.92	15.93	15.93	15.93	86.21
3000	13.27	13.27	13.27	13.27	13.27	13.27	13.27	13.27	49.89
3500	10.74	11.38	11.38	11.38	11.38	11.38	11.38	11.38	31.42
4000	7.94	9.29	9.29	9.29	9.29	9.29	9.29	9.29	21.05
4500	6.07	7.34	7.34	7.34	7.34	7.34	7.34	7.34	14.78
5000	4.74	5.94	5.94	5.94	5.81	5.94	5.94	5.94	10.78
5500	3.79	4.91	4.91	4.91	4.63	4.91	4.91	4.91	8.10
6000	3.09	4.13	4.13	4.13	3.75	4.13	4.13	4.13	6.24
6500	2.56	3.52	3.52	3.52	3.06	3.52	3.52	3.52	4.91
7000	2.14	3.03	3.03	3.03	2.52	2.96	3.03	3.03	3.93
7500	1.82	2.64	2.64	2.64	2.06	2.51	2.64	2.64	3.19
8000	1.56	2.32	2.32	2.32	1.69	2.15	2.32	2.32	2.63
8500	1.34	2.06	2.06	2.06	1.39	1.84	2.06	2.06	2.19
9000	1.17	1.84	1.84	1.84	1.15	1.59	1.83	1.84	1.85
9500	1.03	1.65	1.65	1.65	0.96	1.38	1.62	1.65	1.57
10000	0.91	1.48	1.49	1.49	0.80	1.19	1.43	1.49	1.35
10500	0.80	1.34	1.35	1.35	0.68	1.02	1.28	1.35	1.16
11000	0.72	1.21	1.23	1.23	0.57	0.88	1.14	1.22	1.01
11500	0.64	1.10	1.12	1.12	0.49	0.76	1.02	1.10	0.89
12000	0.57	1.01	1.03	1.03	0.43	0.65	0.91	0.99	0.78

NOTE: All gauges of section C/Z 200 require M12 grade 4.6 bolts unless indicated otherwise. Values shaded require M12 grade 8.8 bolts.

Where strength matters



CONTINUOUS SPAN

Two continuous spans are continuous over two bays of equal span, supported at each end of the purlin and over a central support.

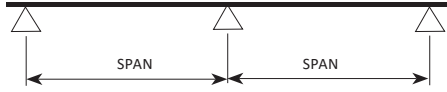

Where strength matters

Span	C/Z 250 - 15											
	Inward				Intward				Def'n L/150			
	0	1	2	3	0	1	2	3				
3000	5.71	5.71	5.71	5.71	5.71	5.71	5.71	5.71	49.13			
3500	4.70	4.70	4.70	4.70	4.70	4.70	4.70	4.70	30.94			
4000	3.95	3.95	3.94	3.95	3.95	3.95	3.95	3.95	20.73			
4500	3.36	3.36	3.36	3.36	3.36	3.36	3.36	3.36	14.56			
5000	2.89	2.89	2.89	2.89	2.89	2.89	2.89	2.89	10.61			
5500	2.51	2.51	2.51	2.51	2.51	2.51	2.51	2.51	7.97			
6000	2.20	2.20	2.20	2.20	2.20	2.20	2.20	2.20	6.14			
6500	1.94	1.94	1.94	1.94	1.94	1.94	1.94	1.94	4.83			
7000	1.65	1.72	1.72	1.72	1.66	1.72	1.72	1.72	3.87			
7500	1.42	1.54	1.54	1.54	1.38	1.54	1.54	1.54	3.14			
8000	1.23	1.38	1.38	1.38	1.15	1.38	1.38	1.38	2.59			
8500	1.07	1.25	1.25	1.25	0.96	1.20	1.25	1.25	2.16			
9000	0.94	1.13	1.13	1.13	0.79	1.04	1.13	1.13	1.82			
9500	0.83	1.03	1.03	1.03	0.66	0.90	1.03	1.03	1.55			
10000	0.73	0.93	0.93	0.93	0.55	0.78	0.93	0.93	1.33			
10500	0.65	0.84	0.84	0.84	0.47	0.68	0.83	0.84	1.15			
11000	0.59	0.77	0.77	0.77	0.40	0.59	0.74	0.77	1.00			
11500	0.53	0.70	0.70	0.70	0.34	0.51	0.66	0.70	0.87			
12000	0.47	0.64	0.64	0.64	0.30	0.44	0.59	0.64	0.77			
12500	0.43	0.59	0.59	0.59	0.26	0.38	0.53	0.58	0.68			

Span	C/Z 250 - 19											
	Inward				Intward				Def'n L/150			
	0	1	2	3	0	1	2	3				
3000	10.51	10.51	10.51	10.51	10.51	10.51	10.51	10.51	64.70			
3500	8.55	8.55	8.55	8.55	8.55	8.55	8.55	8.55	40.74			
4000	7.03	7.03	7.03	7.03	7.03	7.03	7.03	7.03	27.29			
4500	5.87	5.87	5.87	5.87	5.87	5.87	5.87	5.87	19.17			
5000	4.80	4.97	4.97	4.97	4.97	4.97	4.97	4.97	13.97			
5500	3.85	4.25	4.25	4.25	4.25	4.25	4.25	4.25	10.50			
6000	3.15	3.68	3.67	3.68	3.67	3.68	3.68	3.68	8.09			
6500	2.62	3.14	3.14	3.14	2.98	3.14	3.14	3.14	6.36			
7000	2.20	2.70	2.70	2.70	2.42	2.70	2.70	2.70	5.09			
7500	1.87	2.36	2.36	2.36	1.97	2.36	2.36	2.36	4.14			
8000	1.60	2.07	2.07	2.07	1.61	2.07	2.07	2.07	3.41			
8500	1.39	1.83	1.83	1.83	1.32	1.80	1.83	1.83	2.84			
9000	1.21	1.64	1.64	1.64	1.09	1.53	1.64	1.64	2.40			
9500	1.06	1.47	1.47	1.47	0.90	1.31	1.47	1.47	2.04			
10000	0.93	1.33	1.33	1.33	0.75	1.12	1.33	1.33	1.75			
10500	0.83	1.20	1.20	1.20	0.63	0.96	1.20	1.20	1.51			
11000	0.74	1.10	1.10	1.10	0.54	0.82	1.10	1.10	1.31			
11500	0.66	1.00	1.00	1.00	0.46	0.71	0.99	1.00	1.15			
12000	0.59	0.92	0.92	0.92	0.39	0.61	0.89	0.92	1.01			
12500	0.53	0.85	0.85	0.85	0.34	0.52	0.79	0.85	0.89			

Span	C/Z 250 - 24											
	Inward				Intward				Def'n L/150			
	0	1	2	3	0	1	2	3				
3000	13.27	13.27	13.27	13.27	13.27	13.27	13.27	13.27	84.51			
3500	11.37	11.38	11.37	11.38	11.38	11.38	11.37	11.38	53.22			
4000	9.95	9.95	9.95	9.95	9.95	9.95	9.95	9.95	35.65			
4500	7.82	8.85	8.85	8.85	8.85	8.85	8.85	8.85	25.04			
5000	6.06	7.56	7.56	7.56	7.56	7.56	7.56	7.56	18.25			
5500	4.81	6.25	6.25	6.25	6.21	6.25	6.25	6.25	13.72			
6000	3.90	5.25	5.25	5.25	5.00	5.25	5.25	5.25	10.56			
6500	3.20	4.47	4.47	4.47	4.06	4.47	4.47	4.47	8.31			
7000	2.67	3.86	3.86	3.86	3.31	3.86	3.86	3.86	6.65			
7500	2.26	3.36	3.36	3.36	2.68	3.36	3.36	3.36	5.41			
8000	1.93	2.95	2.95	2.95	2.18	2.87	2.95	2.95	4.46			
8500	1.66	2.62	2.62	2.62	1.77	2.45	2.62	2.62	3.72			
9000	1.45	2.33	2.33	2.33	1.46	2.11	2.33	2.33	3.13			
9500	1.27	2.09	2.09	2.09	1.20	1.81	2.09	2.09	2.66			
10000	1.11	1.89	1.89	1.89	1.00	1.54	1.89	1.89	2.28			
10500	0.98	1.71	1.71	1.71	0.84	1.32	1.71	1.71	1.97			
11000	0.87	1.56	1.56	1.56	0.71	1.12	1.52	1.56	1.71			
11500	0.78	1.43	1.43	1.43	0.61	0.96	1.36	1.43	1.50			
12000	0.70	1.31	1.31	1.31	0.52	0.83	1.21	1.31	1.32			
12500	0.63	1.21	1.21	1.21	0.45	0.71	1.09	1.20	1.17			



NOTE: All gauges of section C/Z 250 require M12 grade 4.6 bolts unless indicated otherwise. Values shaded require M12 grade 8.8 bolts.

CONTINUOUS SPAN

Two continuous spans are continuous over two bays of equal span, supported at each end of the purlin and over a central support.

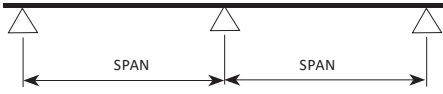

Span	C/Z 300 - 24								
	Inward				Intward				Def'n L/150
	0	1	2	3	0	1	2	3	
4000	12.79	12.79	12.80	12.80	12.80	12.79	12.79	12.79	61.61
4500	10.78	10.78	10.78	10.78	10.78	10.78	10.78	10.78	43.27
5000	8.87	9.20	9.20	9.20	9.20	9.20	9.20	9.20	31.55
5500	6.99	7.93	7.93	7.93	7.93	7.93	7.93	7.93	23.70
6000	5.64	6.89	6.90	6.89	6.89	6.89	6.90	6.89	18.26
6500	4.63	6.05	6.04	6.05	6.05	6.05	6.05	6.04	14.36
7000	3.86	5.34	5.34	5.34	5.34	5.34	5.34	5.34	11.50
7500	3.26	4.73	4.73	4.73	4.60	4.73	4.73	4.73	9.35
8000	2.77	4.16	4.16	4.16	3.88	4.16	4.16	4.16	7.70
8500	2.38	3.68	3.68	3.68	3.29	3.68	3.68	3.68	6.42
9000	2.07	3.29	3.29	3.29	2.80	3.29	3.29	3.29	5.41
9500	1.81	2.95	2.95	2.95	2.38	2.95	2.95	2.95	4.60
10000	1.59	2.66	2.66	2.66	2.04	2.66	2.66	2.66	3.94
10500	1.40	2.41	2.41	2.41	1.75	2.34	2.41	2.41	3.41
11000	1.25	2.20	2.20	2.20	1.51	2.07	2.20	2.20	2.96
11500	1.12	2.01	2.01	2.01	1.30	1.83	2.01	2.01	2.59
12000	1.00	1.85	1.85	1.85	1.12	1.62	1.85	1.85	2.28
12500	0.90	1.70	1.70	1.70	0.96	1.44	1.70	1.70	2.02
13000	0.82	1.58	1.58	1.58	0.83	1.28	1.58	1.58	1.80
13500	0.74	1.46	1.46	1.46	0.73	1.14	1.46	1.46	1.60
14000	0.68	1.36	1.36	1.36	0.64	1.01	1.35	1.36	1.44
14500	0.62	1.27	1.27	1.27	0.56	0.91	1.23	1.27	1.29
15000	0.57	1.18	1.18	1.18	0.50	0.81	1.12	1.18	1.17

Span	C/Z 300 - 30								
	Inward				Intward				Def'n L/150
	0	1	2	3	0	1	2	3	
4000	20.68	20.92	20.92	20.92	20.92	20.92	20.92	20.92	79.33
4500	15.36	17.27	17.27	17.27	17.27	17.27	17.27	17.27	55.72
5000	11.69	14.47	14.47	14.47	14.47	14.47	14.47	14.47	40.62
5500	8.98	12.28	12.28	12.28	12.28	12.28	12.28	12.28	30.52
6000	7.04	10.48	10.48	10.48	10.48	10.48	10.48	10.48	23.51
6500	5.63	8.93	8.93	8.93	8.83	8.93	8.93	8.93	18.49
7000	4.59	7.70	7.70	7.70	7.42	7.70	7.70	7.70	14.80
7500	3.82	6.71	6.71	6.71	6.28	6.71	6.71	6.71	12.04
8000	3.22	5.89	5.89	5.89	5.35	5.89	5.89	5.89	9.92
8500	2.75	5.22	5.22	5.22	4.57	5.22	5.22	5.22	8.27
9000	2.37	4.66	4.66	4.66	3.89	4.65	4.66	4.66	6.97
9500	2.06	4.18	4.18	4.18	3.33	4.09	4.18	4.18	5.92
10000	1.81	3.76	3.77	3.77	2.82	3.62	3.77	3.77	5.08
10500	1.60	3.38	3.42	3.42	2.38	3.21	3.42	3.42	4.39
11000	1.42	3.06	3.12	3.12	2.01	2.86	3.12	3.12	3.82
11500	1.27	2.78	2.85	2.85	1.71	2.56	2.85	2.85	3.34
12000	1.15	2.53	2.62	2.62	1.47	2.28	2.62	2.62	2.94
12500	1.03	2.32	2.41	2.41	1.26	2.03	2.41	2.41	2.60
13000	0.94	2.13	2.23	2.23	1.10	1.81	2.20	2.23	2.31
13500	0.85	1.96	2.07	2.07	0.96	1.61	2.01	2.07	2.06
14000	0.78	1.82	1.92	1.92	0.84	1.42	1.84	1.92	1.85
14500	0.72	1.68	1.79	1.79	0.74	1.25	1.69	1.79	1.67
15000	0.66	1.56	1.68	1.68	0.66	1.10	1.55	1.67	1.50

Where strength matters



NOTE: All gauges of section C/Z 300 require M16 grade 4.6 bolts unless indicated otherwise. Values shaded require M16 grade 8.8 bolts.

Two continuous spans are continuous over two bays of equal span, supported at each end of the purlin and over a central support.

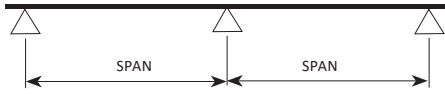

Where strength matters

Span	C/Z 350 - 24								
	Inward				Intward				Def'n L/150
	0	1	2	3	0	1	2	3	
4000	12.26	12.26	12.26	12.26	12.26	12.26	12.26	12.26	99.05
4500	10.53	10.53	10.53	10.53	10.53	10.53	10.53	10.53	69.56
5000	9.14	9.14	9.14	9.14	9.14	9.14	9.14	9.14	50.71
5500	8.01	8.01	8.01	8.00	8.01	8.01	8.01	8.00	38.10
6000	7.07	7.07	7.07	7.07	7.07	7.07	7.07	7.07	29.35
6500	6.28	6.28	6.28	6.28	6.28	6.28	6.28	6.28	23.08
7000	5.21	5.61	5.61	5.61	5.61	5.61	5.61	5.61	18.48
7500	4.32	5.05	5.05	5.05	5.05	5.05	5.05	5.05	15.03
8000	3.64	4.56	4.56	4.56	4.56	4.56	4.56	4.56	12.38
8500	3.10	4.13	4.13	4.13	4.13	4.13	4.13	4.13	10.32
9000	2.67	3.76	3.76	3.76	3.76	3.76	3.76	3.76	8.70
9500	2.33	3.44	3.44	3.44	3.44	3.44	3.44	3.44	7.39
10000	2.04	3.15	3.15	3.15	3.08	3.15	3.15	3.15	6.34
10500	1.80	2.90	2.90	2.90	2.73	2.90	2.90	2.90	5.48
11000	1.60	2.68	2.68	2.68	2.43	2.68	2.68	2.68	4.76
11500	1.44	2.48	2.48	2.48	2.17	2.48	2.48	2.48	4.17
12000	1.29	2.29	2.29	2.29	1.93	2.27	2.29	2.29	3.67
12500	1.17	2.11	2.11	2.11	1.72	2.07	2.11	2.11	3.25
13000	1.06	1.95	1.95	1.95	1.51	1.88	1.95	1.95	2.89
13500	0.97	1.81	1.81	1.81	1.33	1.72	1.81	1.81	2.58
14000	0.88	1.67	1.68	1.68	1.17	1.57	1.68	1.68	2.31
14500	0.81	1.55	1.57	1.57	1.04	1.44	1.57	1.57	2.08
15000	0.75	1.44	1.47	1.47	0.93	1.32	1.47	1.47	1.88

Span	C/Z 350 - 30								
	Inward				Intward				Def'n L/150
	0	1	2	3	0	1	2	3	
4000	21.71	21.70	21.71	21.71	21.71	21.70	21.71	21.70	128.18
4500	18.33	18.34	18.33	18.34	18.33	18.33	18.33	18.33	90.02
5000	15.67	15.67	15.67	15.67	15.67	15.67	15.67	15.67	65.63
5500	12.30	13.53	13.53	13.53	13.53	13.53	13.53	13.53	49.30
6000	9.69	11.79	11.79	11.79	11.79	11.79	11.79	11.79	37.98
6500	7.73	10.36	10.36	10.36	10.36	10.36	10.36	10.36	29.87
7000	6.31	9.16	9.16	9.16	9.16	9.16	9.16	9.16	23.92
7500	5.25	8.14	8.14	8.14	8.14	8.14	8.14	8.14	19.45
8000	4.43	7.16	7.16	7.16	7.16	7.16	7.16	7.16	16.02
8500	3.79	6.34	6.34	6.34	6.34	6.34	6.34	6.34	13.36
9000	3.25	5.65	5.65	5.65	5.63	5.65	5.65	5.65	11.25
9500	2.81	5.07	5.07	5.07	4.91	5.07	5.07	5.07	9.57
10000	2.46	4.58	4.58	4.58	4.29	4.58	4.58	4.58	8.20
10500	2.17	4.15	4.15	4.15	3.75	4.15	4.15	4.15	7.09
11000	1.92	3.79	3.78	3.78	3.29	3.79	3.78	3.78	6.16
11500	1.72	3.46	3.46	3.46	2.89	3.46	3.46	3.46	5.39
12000	1.55	3.18	3.18	3.18	2.54	3.18	3.18	3.18	4.75
12500	1.40	2.93	2.93	2.93	2.23	2.93	2.93	2.93	4.20
13000	1.27	2.71	2.71	2.71	1.96	2.67	2.71	2.71	3.73
13500	1.15	2.51	2.51	2.51	1.73	2.42	2.51	2.51	3.33
14000	1.05	2.33	2.34	2.34	1.54	2.20	2.34	2.34	2.99
14500	0.96	2.16	2.18	2.18	1.37	1.99	2.18	2.18	2.69
15000	0.88	2.00	2.04	2.04	1.23	1.81	2.04	2.04	2.43



NOTE: All gauges of section C/Z 350 require M16 grade 4.6 bolts unless indicated otherwise. Values shaded require M16 grade 8.8 bolts.

CONTINUOUS SPAN

Two continuous spans are continuous over two bays of equal span, supported at each end of the purlin and over a central support.

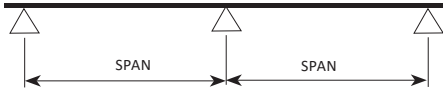

Span	C/Z 400 - 24								
	Inward				Intward				Def'n L/150
	0	1	2	3	0	1	2	3	
4000	11.30	11.30	11.30	11.30	11.30	11.30	11.30	11.30	132.86
4500	9.81	9.81	9.81	9.81	9.81	9.81	9.81	9.81	93.31
5000	8.61	8.61	8.61	8.61	8.61	8.61	8.61	8.61	68.03
5500	7.63	7.63	7.63	7.63	7.63	7.63	7.63	7.63	51.11
6000	6.80	6.80	6.80	6.80	6.80	6.80	6.80	6.80	39.37
6500	6.11	6.11	6.11	6.11	6.11	6.11	6.11	6.11	30.96
7000	5.51	5.51	5.51	5.51	5.51	5.51	5.51	5.51	24.79
7500	4.91	5.00	5.00	5.00	5.00	5.00	5.00	5.00	20.16
8000	4.18	4.55	4.55	4.55	4.55	4.55	4.55	4.55	16.61
8500	3.56	4.16	4.16	4.16	4.16	4.16	4.16	4.16	13.85
9000	3.06	3.81	3.81	3.81	3.81	3.81	3.81	3.81	11.66
9500	2.66	3.51	3.51	3.51	3.51	3.51	3.51	3.51	9.92
10000	2.33	3.24	3.24	3.24	3.24	3.24	3.24	3.24	8.50
10500	2.06	2.99	2.99	2.99	2.99	2.99	2.99	2.99	7.35
11000	1.83	2.78	2.78	2.78	2.70	2.78	2.78	2.78	6.39
11500	1.64	2.58	2.58	2.58	2.40	2.58	2.58	2.58	5.59
12000	1.47	2.41	2.41	2.41	2.14	2.41	2.41	2.41	4.92
12500	1.33	2.25	2.25	2.25	1.90	2.25	2.25	2.25	4.35
13000	1.21	2.10	2.10	2.10	1.70	2.10	2.10	2.10	3.87
13500	1.10	1.97	1.97	1.97	1.52	1.92	1.97	1.97	3.46
14000	1.01	1.85	1.85	1.85	1.36	1.75	1.85	1.85	3.10
14500	0.93	1.73	1.74	1.74	1.21	1.60	1.74	1.74	2.79
15000	0.86	1.61	1.64	1.64	1.07	1.47	1.64	1.64	2.52
15500	0.79	1.50	1.55	1.55	0.96	1.35	1.55	1.55	2.28
16000	0.74	1.40	1.46	1.46	0.86	1.24	1.45	1.46	2.08

Span	C/Z 400 - 24								
	Inward				Intward				Def'n L/150
	0	1	2	3	0	1	2	3	
4000	20.68	20.68	20.68	20.68	20.68	20.68	20.68	20.68	172.88
4500	17.73	17.73	17.73	17.73	17.73	17.73	17.73	17.73	121.41
5000	15.36	15.36	15.36	15.36	15.36	15.36	15.36	15.36	88.51
5500	13.43	13.43	13.43	13.43	13.43	13.43	13.44	13.43	66.50
6000	11.33	11.84	11.84	11.84	11.84	11.84	11.84	11.84	51.22
6500	9.02	10.51	10.51	10.51	10.51	10.51	10.51	10.50	40.29
7000	7.36	9.38	9.38	9.38	9.38	9.38	9.38	9.38	32.26
7500	6.10	8.42	8.42	8.42	8.42	8.42	8.42	8.42	26.23
8000	5.14	7.59	7.59	7.59	7.59	7.59	7.59	7.59	21.61
8500	4.36	6.88	6.88	6.88	6.88	6.88	6.88	6.88	18.02
9000	3.73	6.26	6.26	6.26	6.26	6.26	6.26	6.26	15.18
9500	3.23	5.71	5.71	5.71	5.71	5.71	5.71	5.71	12.91
10000	2.82	5.24	5.24	5.24	5.07	5.24	5.24	5.24	11.06
10500	2.49	4.80	4.80	4.80	4.49	4.80	4.80	4.80	9.56
11000	2.21	4.37	4.37	4.37	3.93	4.37	4.37	4.37	8.31
11500	1.97	4.00	4.00	4.00	3.44	4.00	4.00	4.00	7.28
12000	1.77	3.68	3.68	3.68	3.02	3.68	3.68	3.68	6.40
12500	1.59	3.39	3.39	3.39	2.64	3.39	3.39	3.39	5.67
13000	1.44	3.13	3.13	3.13	2.31	3.10	3.13	3.13	5.04
13500	1.31	2.90	2.90	2.90	2.04	2.83	2.90	2.90	4.50
14000	1.19	2.69	2.70	2.70	1.81	2.59	2.70	2.70	4.03
14500	1.09	2.49	2.52	2.52	1.62	2.38	2.52	2.52	3.63
15000	1.00	2.31	2.35	2.35	1.45	2.17	2.35	2.35	3.28
15500	0.92	2.16	2.20	2.20	1.29	1.97	2.20	2.20	2.97
16000	0.85	2.01	2.07	2.07	1.15	1.79	2.07	2.07	2.70

Where strength matters



NOTE: All gauges of section C/Z 400 require M16 grade 4.6 bolts unless indicated otherwise. Values shaded require M16 grade 8.8 bolts.

TWO LAPPED SPANS

Two lapped spans are continuous over two bays of equal span, supported at each end of the purlin and lapped over a central support.

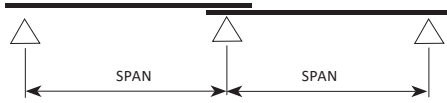

Where strength matters

Span	Z 100 - 10								
	Inward				Intward				Def'n L/150
	0	1	2	3	0	1	2	3	
1500	8.42	8.42	8.42	8.42	8.42	8.42	8.42	8.42	27.14
2000	5.46	5.46	5.46	5.45	5.46	5.46	5.46	5.45	11.45
2500	3.68	3.68	3.68	3.68	3.68	3.68	3.68	3.68	5.86
3000	2.56	2.56	2.56	2.56	2.56	2.56	2.56	2.56	3.39
3500	1.88	1.88	1.88	1.88	1.84	1.88	1.88	1.88	2.14
4000	1.43	1.44	1.44	1.44	1.29	1.44	1.44	1.44	1.43
4500	1.11	1.14	1.14	1.14	0.91	1.13	1.14	1.14	1.01
5000	0.87	0.92	0.92	0.92	0.64	0.85	0.92	0.92	0.73
5500	0.70	0.76	0.76	0.76	0.46	0.65	0.76	0.76	0.55
6000	0.57	0.64	0.64	0.64	0.34	0.49	0.64	0.64	0.42
6500	0.47	0.54	0.54	0.54	0.26	0.37	0.52	0.54	0.33
7000	0.39	0.47	0.47	0.47	0.21	0.29	0.42	0.47	0.27
7500	0.33	0.41	0.41	0.41	0.17	0.22	0.35	0.40	0.22
8000	0.27	0.36	0.36	0.36	0.13	0.18	0.28	0.33	0.18

Span	Z 100 - 12								
	Inward				Intward				Def'n L/150
	0	1	2	3	0	1	2	3	
1500	11.64	11.64	11.64	11.64	11.64	11.64	11.64	11.64	32.80
2000	6.98	6.98	6.98	6.98	6.98	6.98	6.98	6.98	13.84
2500	4.45	4.47	4.47	4.47	4.47	4.47	4.47	4.47	7.09
3000	3.03	3.10	3.10	3.10	3.10	3.10	3.10	3.10	4.10
3500	2.18	2.28	2.28	2.28	2.16	2.28	2.28	2.28	2.58
4000	1.63	1.74	1.75	1.74	1.53	1.74	1.74	1.74	1.73
4500	1.26	1.38	1.38	1.38	1.10	1.32	1.38	1.38	1.22
5000	1.00	1.12	1.12	1.12	0.80	1.01	1.12	1.12	0.89
5500	0.80	0.92	0.92	0.92	0.59	0.78	0.92	0.92	0.67
6000	0.66	0.78	0.78	0.78	0.44	0.60	0.75	0.78	0.51
6500	0.54	0.66	0.66	0.66	0.34	0.47	0.61	0.66	0.40
7000	0.45	0.57	0.57	0.57	0.26	0.36	0.50	0.56	0.32
7500	0.38	0.50	0.50	0.50	0.21	0.29	0.42	0.47	0.26
8000	0.32	0.44	0.44	0.44	0.17	0.23	0.34	0.39	0.22

Span	Z 100 - 15								
	Inward				Intward				Def'n L/150
	0	1	2	3	0	1	2	3	
1500	15.52	15.52	15.52	15.52	15.52	15.52	15.52	15.52	41.77
2000	8.68	9.09	9.09	9.09	9.09	9.09	9.09	9.09	17.62
2500	5.42	5.82	5.82	5.82	5.82	5.82	5.82	5.82	9.02
3000	3.69	4.04	4.04	4.04	3.90	4.04	4.04	4.04	5.22
3500	2.66	2.97	2.97	2.97	2.73	2.97	2.97	2.97	3.29
4000	2.00	2.27	2.27	2.27	1.97	2.20	2.27	2.27	2.20
4500	1.55	1.80	1.80	1.80	1.46	1.67	1.80	1.80	1.55
5000	1.24	1.45	1.45	1.45	1.10	1.29	1.44	1.45	1.13
5500	1.00	1.20	1.20	1.20	0.82	1.02	1.16	1.20	0.85
6000	0.83	1.01	1.01	1.01	0.61	0.81	0.95	1.00	0.65
6500	0.69	0.86	0.86	0.86	0.47	0.65	0.78	0.83	0.51
7000	0.58	0.74	0.74	0.74	0.37	0.51	0.65	0.70	0.41
7500	0.49	0.63	0.65	0.65	0.29	0.40	0.55	0.59	0.33
8000	0.42	0.55	0.57	0.57	0.24	0.32	0.46	0.51	0.28

Span	Z 100 - 19								
	Inward				Intward				Def'n L/150
	0	1	2	3	0	1	2	3	
1500	21.39	21.76	21.76	21.76	21.76	21.76	21.76	21.76	53.51
2000	11.49	12.62	12.62	12.62	12.62	12.62	12.62	12.62	22.58
2500	7.10	8.08	8.08	8.08	8.02	8.08	8.08	8.08	11.56
3000	4.80	5.61	5.61	5.61	5.29	5.61	5.61	5.61	6.69
3500	3.44	4.12	4.12	4.12	3.67	4.07	4.12	4.12	4.21
4000	2.58	3.16	3.16	3.16	2.64	3.00	3.16	3.16	2.82
4500	1.99	2.49	2.49	2.49	1.95	2.27	2.49	2.49	1.98
5000	1.58	2.02	2.02	2.02	1.46	1.75	1.97	2.02	1.45
5500	1.28	1.67	1.67	1.67	1.12	1.37	1.58	1.66	1.09
6000	1.05	1.40	1.40	1.40	0.85	1.08	1.29	1.37	0.84
6500	0.88	1.18	1.20	1.20	0.65	0.87	1.06	1.13	0.66
7000	0.74	1.00	1.03	1.03	0.51	0.70	0.88	0.95	0.53
7500	0.63	0.86	0.89	0.90	0.41	0.56	0.74	0.81	0.43
8000	0.54	0.75	0.77	0.79	0.34	0.45	0.62	0.69	0.35

Span	Z 100 - 24								
	Inward				Intward				Def'n L/150
	0	1	2	3	0	1	2	3	
1500	27.11	27.61	27.60	27.60	27.61	27.60	27.60	27.60	66.77
2000	14.57	16.23	16.23	16.22	16.23	16.23	16.23	16.22	28.17
2500	8.95	10.47	10.47	10.47	10.22	10.47	10.47	10.47	14.42
3000	6.02	7.27	7.27	7.27	6.80	7.27	7.27	7.27	8.35
3500	4.31	5.34	5.34	5.34	4.77	5.21	5.34	5.34	5.26
4000	3.22	4.08	4.09	4.09	3.44	3.86	4.09	4.09	3.52
4500	2.49	3.20	3.23	3.23	2.55	2.95	3.19	3.23	2.47
5000	1.98	2.58	2.62	2.62	1.93	2.29	2.53	2.62	1.80
5500	1.60	2.12	2.16	2.16	1.48	1.80	2.04	2.13	1.36
6000	1.32	1.77	1.82	1.82	1.15	1.43	1.67	1.75	1.04
6500	1.10	1.50	1.55	1.55	0.91	1.15	1.39	1.46	0.82
7000	0.93	1.28	1.32	1.34	0.73	0.93	1.15	1.23	0.66
7500	0.80	1.10	1.14	1.16	0.59	0.76	0.97	1.05	0.53
8000	0.68	0.96	0.99	1.02	0.49	0.63	0.82	0.90	0.44

NOTE: All gauges of section Z100 require M12 grade 4.6 bolts unless indicated otherwise. Values shaded require M12 grade 8.8 bolts.



TWO LAPPED SPANS

Two lapped spans are continuous over two bays of equal span, supported at each end of the purlin and lapped over a central support.



Span	Z 150 - 10								
	Inward				Intward				Def'n L/150
	0	1	2	3	0	1	2	3	
2000	4.90	4.90	4.90	4.90	4.90	4.90	4.90	4.90	31.92
2500	3.73	3.73	3.73	3.73	3.73	3.73	3.73	3.73	16.34
3000	2.95	2.95	2.95	2.95	2.95	2.95	2.95	2.95	9.46
3500	2.39	2.39	2.39	2.39	2.39	2.39	2.39	2.39	5.96
4000	1.97	1.97	1.97	1.97	1.97	1.97	1.97	1.97	3.99
4500	1.65	1.65	1.65	1.65	1.65	1.65	1.65	1.65	2.80
5000	1.40	1.40	1.40	1.40	1.37	1.40	1.40	1.40	2.04
5500	1.17	1.20	1.20	1.20	1.05	1.20	1.20	1.20	1.54
6000	0.97	1.04	1.04	1.04	0.81	1.01	1.04	1.04	1.18
6500	0.81	0.91	0.91	0.91	0.63	0.82	0.91	0.91	0.93
7000	0.68	0.79	0.79	0.79	0.49	0.66	0.79	0.79	0.74
7500	0.58	0.69	0.69	0.69	0.38	0.54	0.67	0.69	0.61
8000	0.50	0.60	0.60	0.60	0.31	0.44	0.57	0.60	0.50
8500	0.43	0.54	0.54	0.54	0.25	0.36	0.49	0.53	0.42
9000	0.37	0.48	0.48	0.48	0.20	0.29	0.42	0.47	0.35
9500	0.32	0.43	0.43	0.43	0.17	0.24	0.36	0.41	0.30
10000	0.28	0.39	0.39	0.39	0.14	0.20	0.31	0.36	0.26

Span	Z 150 - 12								
	Inward				Intward				Def'n L/150
	0	1	2	3	0	1	2	3	
2000	7.87	7.87	7.87	7.87	7.87	7.87	7.87	7.86	39.66
2500	5.82	5.82	5.82	5.82	5.82	5.82	5.82	5.82	20.31
3000	4.48	4.48	4.48	4.48	4.48	4.48	4.48	4.48	11.75
3500	3.54	3.54	3.54	3.54	3.54	3.54	3.54	3.54	7.40
4000	2.86	2.86	2.86	2.86	2.86	2.86	2.86	2.86	4.96
4500	2.29	2.35	2.35	2.35	2.35	2.35	2.35	2.35	3.48
5000	1.82	1.92	1.92	1.92	1.81	1.92	1.92	1.92	2.54
5500	1.48	1.59	1.59	1.59	1.37	1.59	1.59	1.59	1.91
6000	1.21	1.34	1.34	1.34	1.04	1.31	1.34	1.34	1.47
6500	1.01	1.14	1.14	1.14	0.79	1.08	1.14	1.14	1.16
7000	0.85	0.98	0.98	0.98	0.61	0.87	0.98	0.98	0.93
7500	0.72	0.85	0.85	0.86	0.48	0.70	0.86	0.85	0.75
8000	0.61	0.75	0.75	0.75	0.39	0.56	0.75	0.75	0.62
8500	0.52	0.67	0.67	0.67	0.32	0.45	0.64	0.67	0.52
9000	0.45	0.59	0.59	0.59	0.26	0.37	0.55	0.59	0.44
9500	0.39	0.53	0.53	0.53	0.22	0.31	0.47	0.53	0.37
10000	0.34	0.48	0.48	0.48	0.18	0.25	0.40	0.47	0.32

Span	Z 150 - 15								
	Inward				Intward				Def'n L/150
	0	1	2	3	0	1	2	3	
2000	13.13	13.13	13.13	13.12	13.13	13.13	13.13	13.12	51.45
2500	9.29	9.29	9.29	9.29	9.29	9.29	9.29	9.29	26.34
3000	6.68	6.88	6.88	6.88	6.88	6.88	6.88	6.88	15.25
3500	4.77	5.16	5.16	5.16	5.16	5.16	5.16	5.16	9.60
4000	3.56	3.95	3.95	3.95	3.95	3.95	3.95	3.95	6.43
4500	2.75	3.12	3.12	3.12	2.98	3.12	3.12	3.12	4.52
5000	2.18	2.53	2.53	2.53	2.27	2.53	2.53	2.53	3.29
5500	1.76	2.09	2.09	2.09	1.75	2.08	2.09	2.09	2.47
6000	1.44	1.76	1.76	1.76	1.36	1.68	1.76	1.76	1.91
6500	1.20	1.50	1.50	1.50	1.06	1.36	1.50	1.50	1.50
7000	1.01	1.29	1.29	1.29	0.84	1.11	1.29	1.29	1.20
7500	0.86	1.12	1.12	1.12	0.67	0.91	1.12	1.12	0.98
8000	0.74	0.99	0.99	0.99	0.53	0.75	0.96	0.99	0.80
8500	0.64	0.88	0.88	0.88	0.43	0.62	0.82	0.88	0.67
9000	0.55	0.78	0.78	0.78	0.36	0.51	0.70	0.77	0.57
9500	0.48	0.70	0.70	0.70	0.29	0.43	0.61	0.68	0.48
10000	0.42	0.63	0.63	0.63	0.24	0.35	0.52	0.59	0.41

Span	Z 150 - 19								
	Inward				Intward				Def'n L/150
	0	1	2	3	0	1	2	3	
2000	20.78	20.78	20.77	20.77	20.78	20.78	20.78	20.77	65.88
2500	13.02	14.09	14.09	14.09	14.09	14.09	14.09	14.09	33.73
3000	8.71	9.91	9.91	9.91	9.91	9.91	9.91	9.91	19.52
3500	6.20	7.28	7.28	7.28	7.27	7.28	7.28	7.28	12.29
4000	4.62	5.58	5.58	5.58	5.34	5.58	5.58	5.58	8.24
4500	3.56	4.41	4.41	4.41	4.03	4.41	4.41	4.41	5.78
5000	2.81	3.57	3.57	3.57	3.10	3.52	3.57	3.57	4.22
5500	2.27	2.95	2.95	2.95	2.41	2.81	2.95	2.95	3.17
6000	1.85	2.48	2.48	2.48	1.89	2.28	2.48	2.48	2.44
6500	1.54	2.11	2.11	2.11	1.46	1.86	2.11	2.11	1.92
7000	1.29	1.82	1.82	1.82	1.14	1.54	1.78	1.82	1.54
7500	1.09	1.59	1.59	1.59	0.90	1.27	1.52	1.59	1.25
8000	0.93	1.39	1.39	1.39	0.73	1.05	1.30	1.38	1.03
8500	0.80	1.23	1.24	1.24	0.59	0.86	1.12	1.20	0.86
9000	0.69	1.09	1.10	1.10	0.48	0.70	0.96	1.05	0.72
9500	0.60	0.97	0.99	0.99	0.40	0.58	0.84	0.92	0.62
10000	0.53	0.86	0.89	0.89	0.33	0.49	0.73	0.81	0.53

Span	Z 150 - 24								
	Inward				Intward				Def'n L/150
	0	1	2	3	0	1	2	3	
2000	24.70	24.70	24.70	24.69	24.69	24.70	24.69	24.69	84.98
2500	16.97	19.99	19.99	19.99	19.99	19.99	19.99	19.99	43.51
3000	11.19	13.88	13.89	13.89	13.88	13.88	13.89	13.89	25.18
3500	7.87	10.20	10.20	10.20	9.91	10.20	10.20	10.20	15.86
4000	5.81	7.81	7.81	7.81	7.24	7.81	7.81	7.81	10.62
4500	4.45	6.17	6.17	6.17	5.43	6.14	6.17	6.17	7.46
5000	3.48	5.00	5.00	5.00	4.15	4.81	5.00	5.00	5.44
5500	2.79	4.12	4.13	4.13	3.23	3.83	4.13	4.13	4.09
6000	2.27	3.43	3.47	3.47	2.54	3.09	3.47	3.47	3.15
6500	1.87	2.90	2.96	2.96	1.99	2.52	2.90	2.96	2.48
7000	1.57	2.48	2.55	2.55	1.55	2.07	2.44	2.55	1.98
7500	1.33	2.15	2.22	2.22	1.22	1.72	2.07	2.20	1.61
8000	1.13	1.87	1.95	1.95	0.98	1.43	1.76	1.89	1.33
8500	0.98	1.65	1.73	1.73	0.80	1.19	1.51	1.64	1.11
9000	0.85	1.46	1.54	1.54	0.66	0.98	1.31	1.43	0.93
9500	0.74	1.30	1.38	1.38	0.55	0.81	1.13	1.25	0.79
10000	0.65	1.16	1.23	1.25	0.47	0.67	0.98	1.10	0.68

NOTE: All gauges of section Z150 require M12 grade 4.6 bolts unless indicated otherwise. Values shaded require M12 grade 8.8 bolts.

Where strength matters



TWO LAPPED SPANS

Two lapped spans are continuous over two bays of equal span, supported at each end of the purlin and lapped over a central support.

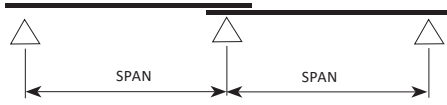

Where strength matters

Span	Z 200 - 12								
	Inward				Intward				Def'n L/150
	0	1	2	3	0	1	2	3	
2500	5.03	5.03	5.03	5.03	5.03	5.03	5.03	5.03	42.71
3000	4.05	4.05	4.05	4.05	4.05	4.05	4.05	4.05	24.72
3500	3.34	3.34	3.34	3.34	3.34	3.34	3.34	3.34	15.57
4000	2.81	2.81	2.81	2.81	2.81	2.81	2.81	2.81	10.43
4500	2.39	2.39	2.39	2.39	2.39	2.39	2.39	2.39	7.32
5000	2.06	2.06	2.06	2.06	2.06	2.06	2.06	2.06	5.34
5500	1.80	1.80	1.80	1.80	1.80	1.80	1.80	1.80	4.01
6000	1.57	1.57	1.57	1.57	1.57	1.57	1.57	1.57	3.09
6500	1.34	1.39	1.39	1.39	1.33	1.39	1.39	1.39	2.43
7000	1.13	1.24	1.24	1.24	1.08	1.24	1.24	1.24	1.95
7500	0.97	1.11	1.11	1.11	0.87	1.09	1.11	1.11	1.58
8000	0.84	0.99	0.99	0.99	0.72	0.92	0.99	0.99	1.30
8500	0.73	0.90	0.90	0.90	0.60	0.78	0.90	0.90	1.09
9000	0.63	0.81	0.81	0.81	0.49	0.66	0.81	0.81	0.92
9500	0.56	0.74	0.74	0.74	0.41	0.56	0.71	0.74	0.78
10000	0.49	0.67	0.67	0.67	0.34	0.48	0.62	0.67	0.67
10500	0.44	0.60	0.60	0.60	0.29	0.41	0.55	0.60	0.58
11000	0.39	0.55	0.55	0.55	0.24	0.36	0.49	0.53	0.50
11500	0.35	0.50	0.50	0.50	0.21	0.30	0.43	0.48	0.44
12000	0.32	0.46	0.46	0.46	0.18	0.26	0.38	0.43	0.39

Span	Z 200 - 15								
	Inward				Intward				Def'n L/150
	0	1	2	3	0	1	2	3	
2500	9.11	9.10	9.11	9.11	9.11	9.10	9.10	9.11	56.12
3000	7.15	7.15	7.15	7.15	7.15	7.15	7.15	7.15	32.48
3500	5.76	5.76	5.76	5.76	5.76	5.76	5.76	5.76	20.45
4000	4.73	4.73	4.73	4.73	4.73	4.73	4.73	4.73	13.70
4500	3.95	3.95	3.95	3.95	3.95	3.95	3.95	3.95	9.62
5000	3.26	3.34	3.34	3.34	3.34	3.34	3.34	3.34	7.02
5500	2.62	2.86	2.86	2.86	2.86	2.86	2.86	2.86	5.27
6000	2.15	2.46	2.46	2.46	2.36	2.46	2.46	2.46	4.06
6500	1.78	2.10	2.10	2.10	1.93	2.10	2.10	2.10	3.19
7000	1.50	1.81	1.81	1.81	1.54	1.81	1.81	1.81	2.56
7500	1.27	1.58	1.58	1.58	1.23	1.56	1.58	1.58	2.08
8000	1.09	1.39	1.39	1.39	0.98	1.33	1.39	1.39	1.71
8500	0.94	1.23	1.23	1.23	0.80	1.14	1.23	1.23	1.43
9000	0.82	1.09	1.09	1.09	0.66	0.96	1.09	1.09	1.20
9500	0.71	0.98	0.98	0.98	0.55	0.80	0.98	0.98	1.02
10000	0.63	0.89	0.89	0.89	0.46	0.67	0.89	0.89	0.88
10500	0.55	0.80	0.80	0.80	0.39	0.57	0.79	0.80	0.76
11000	0.49	0.73	0.73	0.73	0.34	0.48	0.70	0.73	0.66
11500	0.44	0.67	0.67	0.67	0.29	0.41	0.62	0.67	0.58
12000	0.39	0.62	0.62	0.62	0.25	0.35	0.55	0.61	0.51

Span	Z 200 - 19								
	Inward				Intward				Def'n L/150
	0	1	2	3	0	1	2	3	
2500	16.69	16.68	16.69	16.69	16.69	16.69	16.69	16.69	74.94
3000	12.77	12.77	12.77	12.77	12.77	12.77	12.77	12.77	43.37
3500	9.52	10.05	10.04	10.04	10.05	10.05	10.04	10.04	27.31
4000	6.97	8.09	8.09	8.09	8.09	8.09	8.09	8.09	18.30
4500	5.29	6.57	6.57	6.57	6.57	6.57	6.57	6.57	12.85
5000	4.14	5.32	5.32	5.32	5.31	5.32	5.32	5.32	9.37
5500	3.32	4.40	4.40	4.40	4.19	4.40	4.40	4.40	7.04
6000	2.70	3.69	3.69	3.69	3.33	3.69	3.69	3.69	5.42
6500	2.24	3.15	3.15	3.15	2.67	3.15	3.15	3.15	4.26
7000	1.88	2.71	2.71	2.71	2.16	2.68	2.71	2.71	3.41
7500	1.60	2.36	2.36	2.36	1.75	2.24	2.36	2.36	2.78
8000	1.37	2.08	2.08	2.08	1.42	1.89	2.08	2.08	2.29
8500	1.19	1.84	1.84	1.84	1.17	1.60	1.84	1.84	1.91
9000	1.04	1.64	1.64	1.64	0.96	1.35	1.64	1.64	1.61
9500	0.91	1.47	1.47	1.47	0.79	1.15	1.46	1.47	1.37
10000	0.80	1.33	1.33	1.33	0.66	0.98	1.28	1.33	1.17
10500	0.71	1.21	1.21	1.21	0.56	0.83	1.13	1.21	1.01
11000	0.63	1.10	1.10	1.10	0.48	0.71	0.99	1.10	0.88
11500	0.56	1.01	1.01	1.01	0.41	0.61	0.88	0.98	0.77
12000	0.50	0.92	0.92	0.92	0.35	0.52	0.78	0.88	0.68

Span	Z 200 - 24								
	Inward				Intward				Def'n L/150
	0	1	2	3	0	1	2	3	
2500	19.75	19.75	19.75	19.76	19.75	19.76	19.75	19.76	95.94
3000	16.40	16.40	16.40	16.40	16.40	16.40	16.40	16.40	55.52
3500	12.60	14.10	14.10	14.10	14.10	14.10	14.10	14.10	34.96
4000	9.02	11.87	11.87	11.87	11.87	11.87	11.87	11.87	23.42
4500	6.74	9.38	9.38	9.38	9.23	9.38	9.38	9.38	16.45
5000	5.19	7.60	7.60	7.60	7.20	7.60	7.60	7.60	11.99
5500	4.11	6.28	6.28	6.28	5.71	6.28	6.28	6.28	9.01
6000	3.32	5.28	5.28	5.28	4.58	5.26	5.28	5.28	6.94
6500	2.74	4.50	4.50	4.50	3.71	4.36	4.50	4.50	5.46
7000	2.29	3.88	3.88	3.88	2.97	3.65	3.88	3.88	4.37
7500	1.93	3.36	3.38	3.38	2.40	3.08	3.38	3.38	3.55
8000	1.65	2.93	2.97	2.97	1.94	2.61	2.97	2.97	2.93
8500	1.42	2.58	2.63	2.63	1.58	2.23	2.59	2.63	2.44
9000	1.23	2.28	2.34	2.34	1.29	1.89	2.27	2.35	2.06
9500	1.08	2.04	2.10	2.10	1.06	1.60	1.99	2.10	1.75
10000	0.95	1.83	1.90	1.90	0.89	1.36	1.76	1.88	1.50
10500	0.84	1.65	1.72	1.72	0.75	1.15	1.55	1.68	1.30
11000	0.75	1.49	1.57	1.57	0.63	0.98	1.38	1.50	1.13
11500	0.67	1.36	1.44	1.44	0.54	0.84	1.23	1.35	0.99
12000	0.60	1.24	1.32	1.32	0.47	0.71	1.09	1.21	0.87



TWO LAPPED SPANS

Two lapped spans are continuous over two bays of equal span, supported at each end of the purlin and lapped over a central support.

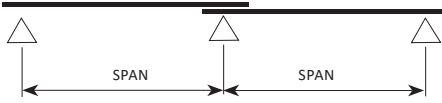

Span	Z 250 - 15											
	Inward				Intward				Def'n L/150			
	0	1	2	3	0	1	2	3				
3000	6.43	6.43	6.43	6.43	6.43	6.43	6.43	6.43	54.84			
3500	5.34	5.34	5.34	5.34	5.34	5.34	5.34	5.34	34.53			
4000	4.52	4.52	4.52	4.52	4.52	4.52	4.52	4.52	23.14			
4500	3.88	3.88	3.88	3.88	3.88	3.88	3.88	3.88	16.25			
5000	3.36	3.36	3.36	3.36	3.36	3.36	3.36	3.36	11.84			
5500	2.94	2.94	2.94	2.94	2.94	2.94	2.94	2.94	8.90			
6000	2.60	2.60	2.60	2.60	2.60	2.60	2.60	2.60	6.86			
6500	2.27	2.31	2.31	2.31	2.31	2.31	2.31	2.31	5.39			
7000	1.92	2.06	2.06	2.06	2.03	2.06	2.06	2.06	4.32			
7500	1.64	1.85	1.85	1.85	1.66	1.85	1.85	1.85	3.51			
8000	1.42	1.67	1.67	1.67	1.37	1.67	1.67	1.67	2.89			
8500	1.23	1.51	1.51	1.51	1.12	1.46	1.51	1.51	2.41			
9000	1.08	1.38	1.38	1.38	0.91	1.25	1.38	1.38	2.03			
9500	0.95	1.26	1.26	1.26	0.76	1.08	1.26	1.26	1.73			
10000	0.83	1.15	1.15	1.15	0.64	0.92	1.14	1.15	1.48			
10500	0.74	1.06	1.06	1.06	0.54	0.80	1.01	1.06	1.28			
11000	0.65	0.98	0.98	0.98	0.46	0.68	0.90	0.97	1.11			
11500	0.58	0.90	0.90	0.90	0.39	0.58	0.80	0.88	0.97			
12000	0.52	0.82	0.82	0.82	0.34	0.50	0.72	0.79	0.86			
12500	0.47	0.76	0.76	0.76	0.29	0.43	0.64	0.71	0.76			

Span	Z 250 - 19											
	Inward				Intward				Def'n L/150			
	0	1	2	3	0	1	2	3				
3000	12.17	12.17	12.17	12.17	12.17	12.17	12.17	12.17	72.22			
3500	9.93	9.93	9.92	9.92	9.93	9.93	9.92	9.92	45.48			
4000	8.25	8.25	8.25	8.25	8.25	8.25	8.25	8.25	30.47			
4500	6.92	6.95	6.95	6.95	6.95	6.95	6.95	6.95	21.40			
5000	5.38	5.93	5.93	5.93	5.93	5.93	5.93	5.93	15.60			
5500	4.28	5.11	5.11	5.11	5.11	5.11	5.11	5.11	11.72			
6000	3.47	4.45	4.45	4.45	4.45	4.45	4.45	4.45	9.03			
6500	2.86	3.90	3.90	3.90	3.59	3.90	3.90	3.90	7.10			
7000	2.40	3.45	3.45	3.45	2.88	3.45	3.45	3.45	5.69			
7500	2.04	3.01	3.01	3.01	2.31	3.01	3.01	3.01	4.62			
8000	1.74	2.65	2.65	2.65	1.87	2.55	2.65	2.65	3.81			
8500	1.50	2.35	2.35	2.35	1.52	2.15	2.35	2.35	3.18			
9000	1.30	2.09	2.09	2.09	1.24	1.81	2.09	2.09	2.68			
9500	1.14	1.88	1.88	1.88	1.02	1.53	1.88	1.88	2.27			
10000	1.00	1.70	1.70	1.70	0.86	1.29	1.70	1.70	1.95			
10500	0.89	1.54	1.54	1.54	0.72	1.09	1.52	1.54	1.68			
11000	0.79	1.40	1.40	1.40	0.61	0.93	1.34	1.40	1.47			
11500	0.71	1.28	1.28	1.28	0.52	0.79	1.18	1.28	1.28			
12000	0.63	1.18	1.18	1.18	0.44	0.68	1.04	1.18	1.13			
12500	0.57	1.09	1.09	1.09	0.38	0.58	0.92	1.07	1.00			

Span	Z 250 - 24											
	Inward				Intward				Def'n L/150			
	0	1	2	3	0	1	2	3				
3000	16.46	16.46	16.46	16.46	16.46	16.46	16.46	16.46	94.05			
3500	14.10	14.10	14.10	14.10	14.10	14.10	14.10	14.10	59.23			
4000	11.50	12.30	12.30	12.30	12.30	12.30	12.30	12.30	39.68			
4500	8.40	10.90	10.90	10.90	10.90	10.90	10.90	10.90	27.87			
5000	6.47	9.66	9.66	9.66	9.66	9.66	9.66	9.66	20.32			
5500	5.10	7.98	7.98	7.98	7.63	7.98	7.98	7.98	15.26			
6000	4.12	6.71	6.71	6.71	6.08	6.71	6.71	6.71	11.76			
6500	3.37	5.72	5.72	5.72	4.87	5.72	5.72	5.72	9.25			
7000	2.80	4.93	4.93	4.93	3.87	4.90	4.93	4.93	7.40			
7500	2.36	4.29	4.29	4.29	3.08	4.11	4.29	4.29	6.02			
8000	2.01	3.77	3.77	3.77	2.47	3.47	3.77	3.77	4.96			
8500	1.73	3.34	3.34	3.34	2.00	2.94	3.34	3.34	4.14			
9000	1.50	2.98	2.98	2.98	1.62	2.48	2.98	2.98	3.48			
9500	1.31	2.68	2.68	2.68	1.33	2.08	2.67	2.68	2.96			
10000	1.16	2.42	2.42	2.42	1.11	1.75	2.35	2.42	2.54			
10500	1.02	2.19	2.19	2.19	0.93	1.47	2.07	2.19	2.19			
11000	0.91	1.98	2.00	2.00	0.79	1.25	1.83	2.00	1.91			
11500	0.82	1.80	1.83	1.83	0.67	1.06	1.62	1.80	1.67			
12000	0.73	1.64	1.68	1.68	0.58	0.90	1.43	1.62	1.47			
12500	0.66	1.50	1.55	1.55	0.50	0.77	1.26	1.46	1.30			

Where strength matters



NOTE: All gauges of section Z250 require M12 grade 4.6 bolts unless indicated otherwise. Values shaded require M12 gauge 8.8 bolts.

TWO LAPPED SPANS

Two lapped spans are continuous over two bays of equal span, supported at each end of the purlin and lapped over a central support.

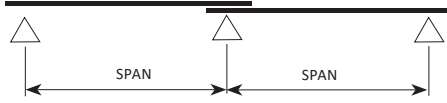

Where strength matters

Span	Z 300 - 24								
	Inward				Intward				Def'n L/150
	0	1	2	3	0	1	2	3	
4000	14.84	14.84	14.84	14.84	14.84	14.84	14.84	14.84	68.73
4500	12.62	12.62	12.61	12.61	12.62	12.62	12.61	12.61	48.27
5000	9.84	10.85	10.85	10.85	10.85	10.85	10.85	10.85	35.19
5500	7.69	9.42	9.42	9.42	9.42	9.42	9.42	9.42	26.44
6000	6.11	8.25	8.25	8.25	8.25	8.25	8.25	8.25	20.36
6500	4.96	7.28	7.28	7.28	7.28	7.28	7.28	7.28	16.02
7000	4.08	6.46	6.46	6.46	6.46	6.46	6.46	6.46	12.82
7500	3.40	5.77	5.77	5.77	5.61	5.77	5.77	5.77	10.43
8000	2.88	5.18	5.18	5.18	4.70	5.18	5.18	5.18	8.59
8500	2.46	4.68	4.68	4.68	3.94	4.68	4.68	4.68	7.16
9000	2.13	4.20	4.20	4.20	3.31	4.20	4.20	4.20	6.03
9500	1.86	3.77	3.77	3.77	2.80	3.70	3.77	3.77	5.13
10000	1.63	3.41	3.41	3.41	2.38	3.23	3.41	3.41	4.40
10500	1.44	3.09	3.09	3.09	2.03	2.83	3.09	3.09	3.80
11000	1.29	2.81	2.81	2.81	1.73	2.48	2.81	2.81	3.31
11500	1.15	2.58	2.58	2.58	1.47	2.18	2.58	2.58	2.89
12000	1.04	2.35	2.36	2.36	1.26	1.91	2.36	2.36	2.55
12500	0.94	2.15	2.18	2.18	1.08	1.68	2.18	2.18	2.25
13000	0.85	1.97	2.01	2.01	0.94	1.48	1.98	2.01	2.00
13500	0.77	1.81	1.87	1.87	0.81	1.31	1.79	1.87	1.79
14000	0.71	1.67	1.74	1.74	0.71	1.16	1.62	1.74	1.60
14500	0.65	1.55	1.62	1.62	0.63	1.02	1.47	1.62	1.44
15000	0.59	1.43	1.51	1.51	0.56	0.90	1.34	1.51	1.30
15500	0.55	1.33	1.42	1.42	0.49	0.80	1.22	1.39	1.18
16000	0.51	1.24	1.33	1.33	0.44	0.71	1.10	1.28	1.07

Span	Z 300 - 30								
	Inward				Intward				Def'n L/150
	0	1	2	3	0	1	2	3	
4000	23.34	23.34	23.34	23.34	23.34	23.34	23.34	22.34	88.48
4500	16.73	20.74	20.74	20.74	20.74	20.74	20.74	20.74	62.14
5000	12.19	17.54	17.54	17.54	17.54	17.54	17.54	17.54	45.30
5500	9.21	14.98	14.98	14.98	14.98	14.98	14.98	14.98	34.03
6000	7.18	12.93	12.93	12.93	12.93	12.93	12.93	12.93	26.22
6500	5.75	11.26	11.26	11.26	10.98	11.26	11.26	11.26	20.62
7000	4.69	9.85	9.85	9.85	9.17	9.85	9.85	9.85	16.51
7500	3.90	8.58	8.58	8.58	7.72	8.58	8.58	8.58	13.42
8000	3.29	7.52	7.54	7.54	6.51	7.54	7.54	7.54	11.06
8500	2.81	6.59	6.68	6.68	5.47	6.60	6.68	6.68	9.22
9000	2.43	5.81	5.96	5.96	4.62	5.76	5.96	5.96	7.77
9500	2.12	5.16	5.35	5.35	3.84	5.05	5.35	5.35	6.60
10000	1.86	4.60	4.83	4.83	3.19	4.45	4.83	4.83	5.66
10500	1.65	4.13	4.38	4.38	2.67	3.93	4.38	4.38	4.89
11000	1.47	3.73	3.99	3.99	2.25	3.47	3.99	3.99	4.25
11500	1.32	3.38	3.65	3.65	1.91	3.06	3.63	3.65	3.72
12000	1.18	3.08	3.35	3.35	1.64	2.69	3.28	3.35	3.28
12500	1.07	2.81	3.09	3.09	1.41	2.37	2.97	3.09	2.90
13000	0.97	2.58	2.86	2.86	1.23	2.07	2.70	2.86	2.58
13500	0.89	2.37	2.65	2.65	1.07	1.80	2.46	2.64	2.30
14000	0.81	2.19	2.46	2.46	0.94	1.57	2.25	2.42	2.06
14500	0.75	2.03	2.28	2.30	0.83	1.37	2.05	2.23	1.86
15000	0.69	1.88	2.12	2.14	0.74	1.20	1.88	2.05	1.68
15500	0.63	1.74	1.97	2.01	0.66	1.06	1.71	1.90	1.52
16000	0.59	1.62	1.84	1.89	0.59	0.94	1.56	1.75	1.38



NOTE: All gauges of section Z300 require M16 grade 4.6 bolts unless indicated otherwise. Values shaded require M16 grade 8.8 bolts.

TWO LAPPED SPANS

Two lapped spans are continuous over two bays of equal span, supported at each end of the purlin and lapped over a central support.

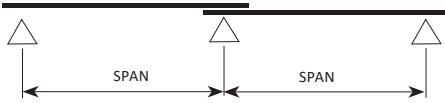

Span	Z 350 - 24								
	Inward				Intward				Def'n L/150
	0	1	2	3	0	1	2	3	
4000	13.89	13.89	13.89	13.89	13.89	13.89	13.89	13.89	110.22
4500	12.01	12.01	12.01	12.01	12.01	12.01	12.01	12.01	77.41
5000	10.50	10.50	10.50	10.50	10.50	10.50	10.50	10.50	56.43
5500	9.26	9.26	9.26	9.26	9.26	9.26	9.26	9.26	42.40
6000	8.23	8.23	8.23	8.23	8.23	8.23	8.23	8.23	32.66
6500	6.74	7.36	7.36	7.36	7.36	7.36	7.36	7.36	25.69
7000	5.50	6.62	6.62	6.62	6.62	6.62	6.62	6.62	20.57
7500	4.56	5.98	5.98	5.98	5.98	5.98	5.98	5.98	16.72
8000	3.84	5.43	5.43	5.43	5.43	5.43	5.43	5.43	13.78
8500	3.27	4.95	4.95	4.95	4.95	4.95	4.95	4.95	11.49
9000	2.82	4.52	4.52	4.52	4.52	4.52	4.52	4.52	9.68
9500	2.45	4.15	4.15	4.15	4.15	4.15	4.15	4.15	8.23
10000	2.16	3.82	3.82	3.82	3.79	3.82	3.82	3.82	7.05
10500	1.92	3.53	3.52	3.53	3.34	3.53	3.52	3.53	6.09
11000	1.71	3.26	3.26	3.26	2.95	3.26	3.26	3.26	5.30
11500	1.54	3.03	3.03	3.03	2.61	3.03	3.03	3.03	4.64
12000	1.39	2.82	2.82	2.82	2.27	2.82	2.82	2.82	4.08
12500	1.26	2.63	2.63	2.63	1.97	2.55	2.63	2.63	3.61
13000	1.14	2.42	2.45	2.45	1.72	2.31	2.45	2.45	3.21
13500	1.04	2.23	2.30	2.30	1.51	2.11	2.30	2.30	2.87
14000	0.95	2.06	2.15	2.15	1.34	1.92	2.15	2.15	2.57
14500	0.87	1.91	2.00	2.00	1.18	1.75	2.00	2.00	2.31
15000	0.80	1.77	1.87	1.87	1.05	1.60	1.86	1.87	2.09
15500	0.74	1.65	1.75	1.75	0.94	1.46	1.73	1.75	1.89
16000	0.69	1.54	1.65	1.65	0.85	1.32	1.60	1.65	1.72

Span	Z 350 - 30								
	Inward				Intward				Def'n L/150
	0	1	2	3	0	1	2	3	
4000	25.09	25.09	25.09	25.09	25.09	25.09	25.09	25.09	142.63
4500	21.38	21.38	21.38	21.37	21.38	21.38	21.38	21.38	100.18
5000	17.60	18.43	18.43	18.43	18.43	18.43	18.43	18.43	73.03
5500	13.31	16.03	16.03	16.03	16.03	16.03	16.03	16.04	54.87
6000	10.41	14.07	14.07	14.07	14.07	14.07	14.07	14.07	42.26
6500	8.35	12.43	12.43	12.43	12.43	12.43	12.43	12.43	33.24
7000	6.76	11.05	11.05	11.05	11.05	11.05	11.05	11.05	26.61
7500	5.56	9.88	9.88	9.88	9.88	9.88	9.88	9.88	21.64
8000	4.66	8.89	8.89	8.89	8.89	8.89	8.89	8.89	17.83
8500	3.95	8.03	8.03	8.03	7.97	8.03	8.03	8.03	14.87
9000	3.40	7.23	7.22	7.22	6.87	7.23	7.22	7.22	12.52
9500	2.94	6.48	6.48	6.48	5.94	6.48	6.48	6.48	10.65
10000	2.56	5.85	5.85	5.85	5.15	5.85	5.85	5.85	9.13
10500	2.25	5.31	5.31	5.31	4.47	5.31	5.31	5.31	7.89
11000	1.99	4.84	4.84	4.84	3.89	4.84	4.84	4.84	6.86
11500	1.77	4.40	4.43	4.43	3.38	4.43	4.43	4.43	6.00
12000	1.59	3.99	4.06	4.06	2.93	3.98	4.06	4.06	5.28
12500	1.43	3.63	3.75	3.75	2.56	3.58	3.75	3.75	4.67
13000	1.30	3.31	3.46	3.46	2.25	3.22	3.46	3.46	4.16
13500	1.18	3.04	3.21	3.21	1.99	2.90	3.21	3.21	3.71
14000	1.08	2.79	2.99	2.99	1.77	2.61	2.99	2.99	3.33
14500	0.99	2.57	2.78	2.78	1.57	2.36	2.78	2.78	2.99
15000	0.91	2.37	2.60	2.60	1.39	2.12	2.60	2.60	2.71
15500	0.84	2.20	2.44	2.44	1.24	1.91	2.44	2.44	2.45
16000	0.77	2.04	2.29	2.29	1.11	1.72	2.28	2.29	2.23

Where strength matters



NOTE: All gauges of section Z350 require M16 grade 4.6 bolts unless indicated otherwise. Values shaded require M16 grade 8.8 bolts.

TWO LAPPED SPANS

Two lapped spans are continuous over two bays of equal span, supported at each end of the purlin and lapped over a central support.

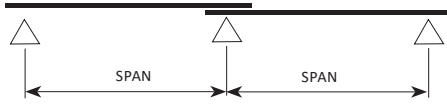

Where strength matters



Span	Z 400 - 24									
	Inward				Intward				Def'n L/150	
	0	1	2	3	0	1	2	3		
4000	12.64	12.64	12.64	12.64	12.64	12.64	12.64	12.64	147.85	
4500	11.03	11.03	11.03	11.03	11.03	11.03	11.03	11.03	103.84	
5000	9.74	9.74	9.74	9.73	9.74	9.74	9.74	9.74	75.70	
5500	8.67	8.67	8.67	8.67	8.67	8.67	8.67	8.67	56.87	
6000	7.78	7.78	7.78	7.78	7.78	7.78	7.78	7.78	43.81	
6500	7.02	7.02	7.02	7.02	7.02	7.02	7.02	7.02	34.46	
7000	6.31	6.37	6.37	6.37	6.37	6.37	6.37	6.37	27.59	
7500	5.22	5.80	5.80	5.80	5.80	5.80	5.80	5.80	22.43	
8000	4.39	5.31	5.31	5.31	5.31	5.31	5.31	5.31	18.48	
8500	3.74	4.88	4.88	4.88	4.88	4.88	4.88	4.88	15.41	
9000	3.22	4.49	4.49	4.49	4.49	4.49	4.49	4.49	12.98	
9500	2.81	4.15	4.15	4.15	4.15	4.15	4.15	4.15	11.04	
10000	2.47	3.84	3.85	3.85	3.85	3.84	3.85	3.85	9.46	
10500	2.20	3.57	3.57	3.57	3.57	3.57	3.57	3.57	8.17	
11000	1.96	3.32	3.32	3.32	3.27	3.32	3.32	3.32	7.11	
11500	1.76	3.10	3.10	3.10	2.89	3.10	3.10	3.10	6.22	
12000	1.58	2.90	2.90	2.90	2.55	2.90	2.90	2.90	5.48	
12500	1.43	2.72	2.72	2.71	2.26	2.72	2.72	2.71	4.85	
13000	1.29	2.55	2.55	2.55	2.00	2.55	2.55	2.55	4.31	
13500	1.18	2.40	2.40	2.40	1.76	2.34	2.40	2.40	3.85	
14000	1.08	2.26	2.26	2.26	1.55	2.13	2.26	2.26	3.45	
14500	0.99	2.12	2.13	2.13	1.37	1.94	2.13	2.13	3.10	
15000	0.91	1.97	2.01	2.01	1.22	1.76	2.01	2.01	2.80	
15500	0.84	1.83	1.90	1.90	1.09	1.61	1.90	1.90	2.54	
16000	0.78	1.71	1.80	1.80	0.98	1.47	1.79	1.80	2.31	
16500	0.72	1.60	1.71	1.71	0.89	1.34	1.66	1.71	2.11	
17000	0.67	1.49	1.62	1.62	0.80	1.22	1.54	1.62	1.93	
17500	0.63	1.40	1.54	1.54	0.73	1.12	1.44	1.54	1.77	
18000	0.58	1.32	1.47	1.47	0.66	1.01	1.34	1.44	1.62	

Span	Z 400 - 30									
	Inward				Intward				Def'n L/150	
	0	1	2	3	0	1	2	3		
4000	23.48	23.49	23.48	23.49	23.34	23.34	23.34	23.34	192.39	
4500	20.28	20.28	20.27	20.28	20.28	20.28	20.28	20.27	135.11	
5000	17.70	17.70	17.70	17.70	17.70	17.70	17.70	17.70	98.50	
5500	15.57	15.59	15.59	15.59	15.59	15.59	15.59	15.59	74.00	
6000	12.15	13.83	13.83	13.83	13.83	13.83	13.83	13.83	57.00	
6500	9.68	12.35	12.35	12.35	12.35	12.35	12.35	12.35	44.83	
7000	7.80	11.09	11.09	11.09	11.09	11.09	11.09	11.09	35.90	
7500	6.41	10.01	10.01	10.01	10.01	10.01	10.01	10.01	29.19	
8000	5.36	9.07	9.07	9.07	9.07	9.07	9.07	9.07	24.05	
8500	4.55	8.26	8.26	8.26	8.26	8.26	8.26	8.26	20.05	
9000	3.89	7.54	7.54	7.54	7.54	7.54	7.54	7.54	16.89	
9500	3.35	6.91	6.91	6.91	6.91	6.91	6.91	6.91	14.36	
10000	2.91	6.36	6.36	6.36	6.16	6.36	6.36	6.36	12.31	
10500	2.56	5.87	5.86	5.86	5.34	5.87	5.86	5.86	10.64	
11000	2.26	5.42	5.42	5.42	4.62	5.42	5.42	5.42	9.25	
11500	2.01	5.03	5.03	5.03	4.00	5.03	5.03	5.03	8.10	
12000	1.80	4.62	4.68	4.68	3.46	4.64	4.68	4.68	7.13	
12500	1.62	4.22	4.33	4.33	3.02	4.20	4.33	4.33	6.30	
13000	1.47	3.87	4.00	4.00	2.66	3.82	4.00	4.00	5.60	
13500	1.33	3.56	3.71	3.71	2.35	3.47	3.71	3.71	5.00	
14000	1.22	3.28	3.45	3.45	2.08	3.12	3.45	3.45	4.49	
14500	1.11	3.04	3.22	3.22	1.83	2.81	3.22	3.22	4.04	
15000	1.02	2.81	3.01	3.01	1.63	2.53	3.01	3.01	3.65	
15500	0.94	2.60	2.82	2.82	1.45	2.27	2.82	2.82	3.31	
16000	0.87	2.41	2.64	2.64	1.30	2.04	2.64	2.64	3.01	
16500	0.81	2.24	2.48	2.48	1.17	1.83	2.45	2.48	2.74	
17000	0.75	2.09	2.34	2.34	1.05	1.66	2.28	2.34	2.51	
17500	0.70	1.95	2.21	2.21	0.94	1.50	2.13	2.21	2.30	
18000	0.65	1.82	2.09	2.09	0.85	1.37	1.98	2.09	2.11	

NOTE: All gauges of section Z400 require M16 grade 4.6 bolts unless indicated otherwise. Values shaded require M16 grade 8.8 bolts.

THREE LAPPED SPANS

Three lapped spans are continuous over three bays, supported at each end of the purlin and lapped over two internal supports.

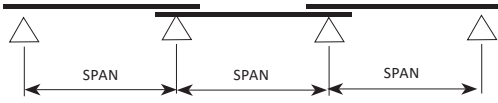

Span	Z 100 - 10								
	Inward				Intward				Def'n L/150
	0	1	2	3	0	1	2	3	
1500	9.82	9.82	9.81	9.81	9.82	9.82	9.81	9.81	20.26
2000	6.61	6.61	6.61	6.61	6.61	6.61	6.61	6.61	8.55
2500	4.65	4.65	4.65	4.65	4.65	4.65	4.65	4.65	4.38
3000	3.16	3.23	3.23	3.23	2.98	3.23	3.23	3.23	2.53
3500	2.25	2.38	2.37	2.38	1.89	2.37	2.37	2.37	1.60
4000	1.66	1.82	1.82	1.82	1.20	1.69	1.82	1.82	1.07
4500	1.26	1.44	1.44	1.44	0.80	1.20	1.44	1.44	0.75
5000	0.97	1.16	1.16	1.16	0.56	0.85	1.16	1.16	0.55
5500	0.75	0.96	0.96	0.96	0.41	0.60	0.90	0.96	0.41
6000	0.59	0.81	0.81	0.81	0.30	0.44	0.70	0.80	0.32
6500	0.46	0.69	0.69	0.69	0.23	0.34	0.54	0.65	0.25
7000	0.37	0.59	0.59	0.59	0.17	0.26	0.42	0.52	0.20
7500	0.30	0.52	0.52	0.52	0.13	0.21	0.33	0.43	0.16
8000	0.24	0.46	0.46	0.46	0.11	0.16	0.26	0.34	0.13

Span	Z 100 - 12								
	Inward				Intward				Def'n L/150
	0	1	2	3	0	1	2	3	
1500	14.36	14.36	14.35	14.35	14.36	14.36	14.35	14.35	24.48
2000	8.59	8.82	8.82	8.82	8.82	8.82	8.82	8.82	10.33
2500	5.32	5.65	5.65	5.65	5.57	5.65	5.65	5.65	5.29
3000	3.59	3.92	3.92	3.92	3.52	3.92	3.92	3.92	3.06
3500	2.56	2.88	2.88	2.88	2.28	2.81	2.88	2.88	1.93
4000	1.90	2.21	2.21	2.21	1.50	2.00	2.21	2.21	1.29
4500	1.45	1.74	1.74	1.74	1.01	1.44	1.74	1.74	0.91
5000	1.12	1.41	1.41	1.41	0.71	1.04	1.35	1.41	0.66
5500	0.88	1.17	1.17	1.17	0.50	0.76	1.06	1.16	0.50
6000	0.70	0.98	0.98	0.98	0.37	0.57	0.83	0.94	0.38
6500	0.56	0.84	0.84	0.84	0.28	0.43	0.66	0.76	0.30
7000	0.45	0.72	0.72	0.72	0.21	0.33	0.52	0.62	0.24
7500	0.37	0.62	0.63	0.63	0.17	0.26	0.41	0.51	0.20
8000	0.31	0.54	0.55	0.55	0.13	0.20	0.33	0.42	0.16

Span	Z 100 - 15								
	Inward				Intward				Def'n L/150
	0	1	2	3	0	1	2	3	
1500	19.44	19.77	19.77	19.77	19.77	19.77	19.77	19.77	31.17
2000	10.48	11.49	11.49	11.49	11.49	11.49	11.49	11.49	13.15
2500	6.50	7.36	7.36	7.36	6.98	7.36	7.36	7.36	6.73
3000	4.39	5.11	5.11	5.11	4.50	5.05	5.11	5.11	3.90
3500	3.15	3.75	3.75	3.75	3.02	3.54	3.75	3.75	2.45
4000	2.35	2.87	2.87	2.87	2.06	2.56	2.86	2.87	1.64
4500	1.81	2.27	2.27	2.27	1.38	1.89	2.19	2.27	1.16
5000	1.43	1.84	1.84	1.84	0.96	1.42	1.71	1.81	0.84
5500	1.14	1.52	1.52	1.52	0.69	1.06	1.36	1.46	0.63
6000	0.92	1.27	1.28	1.28	0.50	0.77	1.09	1.19	0.49
6500	0.74	1.07	1.09	1.09	0.38	0.58	0.88	0.98	0.38
7000	0.60	0.91	0.94	0.94	0.29	0.45	0.71	0.81	0.31
7500	0.49	0.78	0.82	0.82	0.23	0.35	0.58	0.68	0.25
8000	0.41	0.67	0.71	0.72	0.19	0.28	0.46	0.57	0.21

Span	Z 100 - 19								
	Inward				Intward				Def'n L/150
	0	1	2	3	0	1	2	3	
1500	25.79	27.69	27.69	27.69	27.70	27.69	27.69	27.69	39.94
2000	13.64	15.96	15.96	15.96	15.83	15.96	15.96	15.96	16.85
2500	8.34	10.21	10.21	10.21	9.44	10.21	10.21	10.21	8.63
3000	5.59	7.09	7.09	7.09	6.02	6.89	7.09	7.09	4.99
3500	3.98	5.21	5.21	5.21	4.00	4.79	5.21	5.21	3.14
4000	2.96	3.96	3.99	3.99	2.73	3.44	3.92	3.99	2.11
4500	2.28	3.10	3.15	3.15	1.85	2.53	2.98	3.15	1.48
5000	1.79	2.49	2.55	2.55	1.28	1.88	2.32	2.48	1.08
5500	1.44	2.05	2.11	2.11	0.92	1.42	1.83	1.98	0.81
6000	1.17	1.71	1.77	1.77	0.69	1.05	1.46	1.61	0.62
6500	0.95	1.44	1.51	1.51	0.53	0.79	1.17	1.32	0.49
7000	0.78	1.23	1.30	1.30	0.41	0.61	0.95	1.09	0.39
7500	0.65	1.05	1.13	1.14	0.33	0.47	0.77	0.90	0.32
8000	0.54	0.91	0.97	1.00	0.27	0.38	0.62	0.76	0.26

Span	Z 100 - 24								
	Inward				Intward				Def'n L/150
	0	1	2	3	0	1	2	3	
1500	32.80	35.13	35.13	35.13	35.14	35.13	35.13	35.13	49.84
2000	17.14	20.60	20.60	20.60	20.17	20.60	20.60	20.60	21.03
2500	10.38	13.24	13.24	13.24	12.17	13.22	13.24	13.24	10.77
3000	6.91	9.08	9.20	9.20	7.80	8.82	9.20	9.20	6.23
3500	4.90	6.58	6.76	6.76	5.18	6.20	6.73	6.76	3.92
4000	3.64	4.98	5.17	5.17	3.54	4.48	5.01	5.17	2.63
4500	2.80	3.89	4.09	4.09	2.45	3.29	3.84	4.01	1.85
5000	2.21	3.13	3.29	3.31	1.73	2.46	3.01	3.17	1.35
5500	1.78	2.56	2.70	2.74	1.26	1.86	2.38	2.55	1.01
6000	1.45	2.14	2.25	2.30	0.96	1.41	1.90	2.09	0.78
6500	1.20	1.81	1.91	1.95	0.74	1.07	1.53	1.71	0.61
7000	1.01	1.56	1.64	1.67	0.59	0.83	1.24	1.42	0.49
7500	0.85	1.35	1.42	1.45	0.48	0.66	1.01	1.18	0.40
8000	0.72	1.18	1.24	1.27	0.40	0.53	0.83	0.99	0.33

NOTE: All gauges of section Z100 require M12 grade 4.6 bolts unless indicated otherwise. Values shaded require M12 grade 8.8 bolts.

Where strength matters



THREE LAPPED SPANS

Three lapped spans are continuous over three bays, supported at each end of the purlin and lapped over two internal supports.

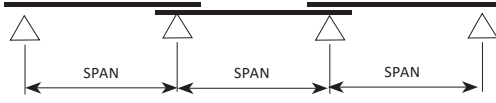

Where strength matters

Span	Z 150 - 10											
	Inward				Intward				Def'n L/150			
	0	1	2	3	0	1	2	3				
2000	5.37	5.37	5.37	5.37	5.37	5.37	5.37	5.37	23.82			
2500	4.16	4.16	4.16	4.16	4.16	4.16	4.16	4.16	12.20			
3000	3.35	3.35	3.35	3.35	3.35	3.35	3.35	3.35	7.06			
3500	2.76	2.76	2.76	2.76	2.76	2.76	2.76	2.76	4.45			
4000	2.32	2.32	2.32	2.32	2.32	2.32	2.32	2.32	2.98			
4500	1.97	1.97	1.97	1.97	1.90	1.97	1.97	1.97	2.09			
5000	1.68	1.70	1.70	1.70	1.37	1.70	1.70	1.70	1.53			
5500	1.35	1.48	1.48	1.48	0.98	1.39	1.48	1.48	1.15			
6000	1.09	1.29	1.29	1.29	0.72	1.08	1.29	1.29	0.88			
6500	0.90	1.14	1.14	1.14	0.54	0.84	1.11	1.14	0.69			
7000	0.74	1.00	1.00	1.00	0.42	0.65	0.91	1.00	0.56			
7500	0.62	0.87	0.87	0.87	0.33	0.51	0.76	0.84	0.45			
8000	0.52	0.76	0.76	0.76	0.27	0.40	0.63	0.72	0.37			
8500	0.43	0.68	0.68	0.68	0.21	0.32	0.52	0.61	0.31			
9000	0.36	0.60	0.60	0.60	0.17	0.26	0.44	0.52	0.26			
9500	0.31	0.54	0.54	0.54	0.14	0.22	0.36	0.45	0.22			
10000	0.26	0.48	0.49	0.49	0.12	0.18	0.30	0.38	0.19			

Span	Z 150 - 12											
	Inward				Intward				Def'n L/150			
	0	1	2	3	0	1	2	3				
2000	8.86	8.86	8.86	8.86	8.86	8.86	8.86	8.86	29.60			
2500	6.72	6.72	6.72	6.72	6.72	6.72	6.72	6.72	15.16			
3000	5.29	5.29	5.29	5.29	5.29	5.29	5.29	5.29	8.77			
3500	4.27	4.27	4.27	4.27	4.27	4.27	4.27	4.27	5.52			
4000	3.44	3.51	3.51	3.51	3.51	3.51	3.51	3.51	3.70			
4500	2.63	2.93	2.93	2.93	2.45	2.93	2.93	2.93	2.60			
5000	2.06	2.43	2.43	2.43	1.71	2.36	2.43	2.43	1.89			
5500	1.64	2.01	2.01	2.01	1.22	1.83	2.01	2.01	1.42			
6000	1.33	1.69	1.69	1.69	0.90	1.40	1.69	1.69	1.10			
6500	1.08	1.44	1.44	1.44	0.69	1.06	1.44	1.44	0.86			
7000	0.88	1.24	1.24	1.24	0.54	0.81	1.20	1.24	0.69			
7500	0.73	1.08	1.08	1.08	0.42	0.64	0.99	1.08	0.56			
8000	0.61	0.95	0.95	0.95	0.33	0.51	0.82	0.94	0.46			
8500	0.51	0.84	0.84	0.84	0.27	0.41	0.67	0.80	0.39			
9000	0.43	0.75	0.75	0.75	0.21	0.34	0.55	0.69	0.33			
9500	0.37	0.67	0.67	0.67	0.18	0.28	0.45	0.58	0.28			
10000	0.32	0.61	0.61	0.61	0.15	0.23	0.38	0.49	0.24			

Span	Z 150 - 15											
	Inward				Intward				Def'n L/150			
	0	1	2	3	0	1	2	3				
2000	15.53	15.53	15.52	15.52	15.53	15.53	15.52	15.52	38.40			
2500	11.32	11.32	11.32	11.32	11.32	11.32	11.32	11.32	19.66			
3000	7.79	8.59	8.60	8.60	8.60	8.60	8.60	8.60	11.38			
3500	5.51	6.52	6.52	6.52	6.27	6.52	6.52	6.52	7.17			
4000	4.07	5.00	5.00	5.00	4.43	5.00	5.00	5.00	4.80			
4500	3.11	3.95	3.95	3.95	3.16	3.92	3.95	3.95	3.37			
5000	2.45	3.20	3.20	3.20	2.28	3.00	3.20	3.20	2.46			
5500	1.96	2.64	2.64	2.64	1.67	2.33	2.64	2.64	1.85			
6000	1.59	2.22	2.22	2.22	1.23	1.81	2.22	2.22	1.42			
6500	1.31	1.89	1.89	1.89	0.93	1.42	1.84	1.89	1.12			
7000	1.09	1.63	1.63	1.63	0.71	1.11	1.52	1.63	0.90			
7500	0.92	1.42	1.42	1.42	0.55	0.88	1.26	1.40	0.73			
8000	0.78	1.25	1.25	1.25	0.44	0.70	1.05	1.19	0.60			
8500	0.66	1.11	1.11	1.11	0.35	0.56	0.88	1.02	0.50			
9000	0.56	0.99	0.99	0.99	0.28	0.46	0.73	0.87	0.42			
9500	0.48	0.88	0.89	0.89	0.23	0.37	0.62	0.75	0.36			
10000	0.41	0.78	0.80	0.80	0.19	0.31	0.52	0.64	0.31			

Span	Z 150 - 19											
	Inward				Intward				Def'n L/150			
	0	1	2	3	0	1	2	3				
2000	25.49	26.02	26.01	26.01	26.02	26.02	26.01	26.01	49.17			
2500	15.34	17.95	17.95	17.95	17.95	17.95	17.95	17.95	25.17			
3000	10.12	12.54	12.54	12.54	12.26	12.54	12.54	12.54	14.57			
3500	7.09	9.21	9.21	9.21	8.48	9.21	9.21	9.21	9.17			
4000	5.17	7.05	7.05	7.05	6.05	6.98	7.05	7.05	6.15			
4500	3.91	5.57	5.57	5.57	4.39	5.29	5.57	5.57	4.32			
5000	3.04	4.51	4.51	4.51	3.13	4.08	4.51	4.51	3.15			
5500	2.41	3.71	3.73	3.73	2.24	3.19	3.70	3.73	2.36			
6000	1.95	3.09	3.13	3.13	1.65	2.52	3.02	3.13	1.82			
6500	1.61	2.62	2.67	2.67	1.23	1.97	2.49	2.66	1.43			
7000	1.34	2.24	2.30	2.30	0.94	1.53	2.07	2.24	1.15			
7500	1.13	1.94	2.01	2.01	0.73	1.19	1.73	1.90	0.93			
8000	0.96	1.69	1.76	1.76	0.58	0.95	1.46	1.62	0.77			
8500	0.82	1.49	1.56	1.56	0.47	0.75	1.23	1.39	0.64			
9000	0.70	1.32	1.39	1.39	0.38	0.61	1.02	1.20	0.54			
9500	0.60	1.18	1.25	1.25	0.32	0.50	0.85	1.04	0.46			
10000	0.52	1.05	1.13	1.13	0.27	0.41	0.71	0.90	0.39			

Span	Z 150 - 24											
	Inward				Intward				Def'n L/150			
	0	1	2	3	0	1	2	3				
2000	28.36	28.36	28.36	28.37	28.36	28.36	28.36	28.37	63.43			
2500	19.62	22.50	22.50	22.50	22.50	22.50	22.50	22.50	32.47			
3000	12.71	17.56	17.56	17.56	16.68	17.56	17.56	17.56	18.79			
3500	8.70	12.90	12.90	12.90	11.44	12.90	12.90	12.90	11.84			
4000	6.25	9.79	9.88	9.88	8.09	9.54	9.88	9.88	7.93			
4500	4.67	7.59	7.80	7.80	5.84	7.19	7.80	7.80	5.57			
5000	3.60	6.05	6.32	6.32	4.21	5.52	6.31	6.32	4.06			
5500	2.86	4.93	5.22	5.22	3.00	4.30	5.06	5.22	3.05			
6000	2.32	4.09	4.39	4.39	2.19	3.38	4.11	4.38	2.35			
6500	1.91	3.44	3.74	3.74	1.65	2.67	3.38	3.64	1.85			
7000	1.60	2.94	3.20	3.22	1.27	2.08	2.80	3.05	1.48			
7500	1.35	2.54	2.76	2.81	1.00	1.61	2.33	2.58	1.20			
8000	1.15	2.21	2.41	2.47	0.80	1.27	1.96	2.20	0.99			
8500	0.99	1.94	2.12	2.19	0.65	1.02	1.65	1.88	0.83			
9000	0.86	1.72	1.88	1.94	0.54	0.83	1.39	1.62	0.70			
9500	0.75	1.53	1.67	1.73	0.45	0.68	1.16	1.40	0.59			
10000	0.66	1.37	1.50	1.55	0.38	0.56	0.97	1.21	0.51			

NOTE: All gauges of section Z150 require M12 grade 4.6 bolts unless indicated otherwise. Values shaded require M12 grade 8.8 bolts.



THREE LAPPED SPANS

Three lapped spans are continuous over three bays, supported at each end of the purlin and lapped over two internal supports.

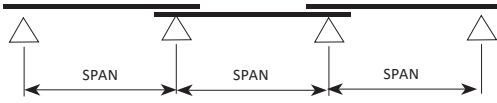

Span	Z 200 - 12								
	Inward				Intward				Def'n L/150
	0	1	2	3	0	1	2	3	
2500	5.49	5.49	5.49	5.49	5.49	5.49	5.49	5.49	31.88
3000	4.48	4.48	4.48	4.48	4.48	4.48	4.48	4.48	18.45
3500	3.75	3.75	3.74	3.74	3.75	3.75	3.75	3.74	11.62
4000	3.19	3.19	3.19	3.19	3.19	3.19	3.19	3.19	7.78
4500	2.76	2.76	2.76	2.76	2.76	2.76	2.76	2.76	5.47
5000	2.40	2.40	2.40	2.40	2.40	2.40	2.40	2.40	3.99
5500	2.12	2.12	2.12	2.12	2.12	2.12	2.12	2.12	2.99
6000	1.81	1.88	1.88	1.88	1.68	1.88	1.88	1.88	2.31
6500	1.50	1.68	1.68	1.68	1.32	1.68	1.68	1.68	1.81
7000	1.27	1.51	1.51	1.51	1.02	1.44	1.51	1.51	1.45
7500	1.08	1.36	1.36	1.36	0.80	1.17	1.36	1.36	1.18
8000	0.92	1.23	1.23	1.23	0.64	0.96	1.23	1.23	0.97
8500	0.80	1.12	1.12	1.12	0.52	0.79	1.07	1.12	0.81
9000	0.69	1.03	1.03	1.03	0.42	0.66	0.92	1.01	0.68
9500	0.60	0.93	0.93	0.93	0.35	0.54	0.79	0.89	0.58
10000	0.52	0.84	0.84	0.84	0.30	0.45	0.68	0.78	0.50
10500	0.46	0.76	0.76	0.76	0.25	0.38	0.59	0.69	0.43
11000	0.40	0.69	0.69	0.69	0.21	0.32	0.51	0.60	0.37
11500	0.35	0.62	0.64	0.64	0.18	0.27	0.44	0.53	0.33
12000	0.31	0.57	0.58	0.58	0.15	0.24	0.39	0.47	0.29

Span	Z 200 - 15								
	Inward				Intward				Def'n L/150
	0	1	2	3	0	1	2	3	
2500	10.23	10.22	10.23	10.23	10.23	10.22	10.23	10.23	41.88
3000	8.19	8.19	8.19	8.19	8.19	8.19	8.19	8.19	24.24
3500	6.72	6.72	6.72	6.72	6.72	6.72	6.72	6.72	15.26
4000	5.62	5.62	5.62	5.62	5.62	5.62	5.62	5.62	10.23
4500	4.60	4.76	4.76	4.76	4.76	4.76	4.76	4.76	7.18
5000	3.58	4.08	4.08	4.08	4.08	4.08	4.08	4.08	5.24
5500	2.84	3.54	3.54	3.54	3.15	3.54	3.54	3.54	3.93
6000	2.30	3.09	3.09	3.09	2.35	3.09	3.09	3.09	3.03
6500	1.90	2.65	2.65	2.65	1.77	2.54	2.65	2.65	2.38
7000	1.58	2.29	2.29	2.29	1.36	2.09	2.29	2.29	1.91
7500	1.34	1.99	1.99	1.99	1.08	1.68	1.99	1.99	1.55
8000	1.14	1.75	1.75	1.75	0.87	1.35	1.75	1.75	1.28
8500	0.98	1.55	1.55	1.55	0.70	1.09	1.53	1.55	1.07
9000	0.84	1.38	1.38	1.38	0.57	0.88	1.32	1.38	0.90
9500	0.73	1.24	1.24	1.24	0.47	0.73	1.15	1.24	0.76
10000	0.64	1.12	1.12	1.12	0.39	0.61	0.99	1.11	0.65
10500	0.56	1.02	1.02	1.02	0.33	0.52	0.84	0.98	0.57
11000	0.50	0.93	0.93	0.93	0.28	0.44	0.72	0.87	0.49
11500	0.44	0.85	0.85	0.85	0.23	0.37	0.61	0.77	0.43
12000	0.39	0.78	0.78	0.78	0.20	0.32	0.52	0.68	0.38

Span	Z 200 - 19								
	Inward				Intward				Def'n L/150
	0	1	2	3	0	1	2	3	
2500	19.39	19.39	19.39	19.39	19.39	19.39	19.39	19.39	55.93
3000	15.19	15.19	15.19	15.19	15.19	15.19	15.19	15.19	32.27
3500	10.70	12.21	12.20	12.20	12.21	12.21	12.20	12.20	20.38
4000	7.71	10.01	10.01	10.01	10.01	10.01	10.01	10.01	13.65
4500	5.78	8.30	8.30	8.30	7.78	8.30	8.30	8.30	9.59
5000	4.47	6.72	6.72	6.72	5.84	6.72	6.72	6.72	6.99
5500	3.56	5.56	5.56	5.56	4.41	5.56	5.56	5.56	5.25
6000	2.89	4.67	4.67	4.67	3.36	4.47	4.67	4.67	4.05
6500	2.38	3.98	3.98	3.98	2.57	3.61	3.98	3.98	3.18
7000	1.98	3.43	3.43	3.43	1.98	2.93	3.43	3.43	2.55
7500	1.67	2.99	2.99	2.99	1.55	2.38	2.99	2.99	2.07
8000	1.43	2.63	2.63	2.63	1.23	1.94	2.57	2.63	1.71
8500	1.23	2.32	2.33	2.33	0.99	1.59	2.19	2.33	1.42
9000	1.07	2.06	2.08	2.08	0.80	1.31	1.88	2.08	1.20
9500	0.93	1.83	1.86	1.86	0.65	1.07	1.62	1.82	1.02
10000	0.82	1.64	1.68	1.68	0.54	0.89	1.39	1.60	0.87
10500	0.73	1.48	1.53	1.53	0.45	0.74	1.20	1.40	0.76
11000	0.64	1.34	1.39	1.39	0.38	0.63	1.03	1.24	0.66
11500	0.57	1.22	1.27	1.27	0.32	0.53	0.89	1.09	0.58
12000	0.51	1.11	1.17	1.17	0.28	0.45	0.77	0.96	0.51

Span	Z 200 - 24								
	Inward				Intward				Def'n L/150
	0	1	2	3	0	1	2	3	
2500	22.69	22.69	22.69	22.69	22.69	22.69	22.69	22.69	71.61
3000	18.91	18.91	18.91	18.91	18.91	18.91	18.91	18.91	41.44
3500	13.62	16.21	16.21	16.21	16.21	16.21	16.21	16.21	26.10
4000	9.57	14.18	14.18	14.18	14.18	14.18	14.18	14.18	17.48
4500	7.07	11.86	11.86	11.86	10.65	11.86	11.86	11.86	12.28
5000	5.37	9.60	9.60	9.61	8.08	9.50	9.60	9.61	8.95
5500	4.21	7.83	7.94	7.94	6.09	7.58	7.94	7.94	6.73
6000	3.38	6.48	6.67	6.67	4.58	6.12	6.67	6.67	5.18
6500	2.77	5.45	5.68	5.68	3.47	4.98	5.68	5.68	4.07
7000	2.31	4.64	4.90	4.90	2.64	4.08	4.83	4.90	3.26
7500	1.95	3.99	4.27	4.27	2.04	3.31	4.10	4.27	2.65
8000	1.66	3.47	3.75	3.75	1.61	2.69	3.51	3.75	2.19
8500	1.44	3.04	3.32	3.32	1.29	2.18	3.01	3.26	1.82
9000	1.25	2.69	2.96	2.96	1.05	1.78	2.60	2.84	1.54
9500	1.09	2.39	2.63	2.66	0.86	1.45	2.25	2.49	1.31
10000	0.96	2.14	2.36	2.40	0.72	1.19	1.94	2.19	1.12
10500	0.85	1.93	2.13	2.18	0.60	0.99	1.67	1.94	0.97
11000	0.76	1.74	1.93	1.98	0.51	0.83	1.43	1.71	0.84
11500	0.68	1.58	1.75	1.81	0.44	0.70	1.23	1.52	0.74
12000	0.61	1.45	1.60	1.66	0.38	0.60	1.06	1.34	0.65

NOTE: All gauges of section Z200 require M12 grade 4.6 bolts unless indicated otherwise. Values shaded require M12 grade 8.8 bolts.

Where strength matters



THREE LAPPED SPANS

Three lapped spans are continuous over three bays, supported at each end of the purlin and lapped over two internal supports.

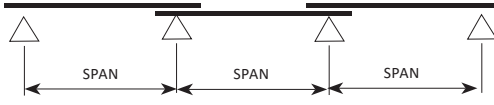

Where strength matters

Span	Z 250 - 15								Def'n L/150
	Inward				Intward				
	0	1	2	3	0	1	2	3	
3000	7.04	7.04	7.04	7.04	7.04	7.04	7.04	7.04	40.93
3500	5.91	5.91	5.91	5.91	5.91	5.91	5.91	5.91	25.78
4000	5.06	5.06	5.06	5.06	5.06	5.06	5.06	5.06	17.27
4500	4.40	4.40	4.40	4.39	4.40	4.40	4.40	4.40	12.13
5000	3.86	3.86	3.86	3.86	3.86	3.86	3.86	3.86	8.84
5500	3.42	3.42	3.42	3.42	3.42	3.42	3.42	3.42	6.64
6000	3.05	3.05	3.05	3.05	3.05	3.05	3.05	3.05	5.12
6500	2.52	2.73	2.73	2.73	2.50	2.74	2.73	2.73	4.02
7000	2.10	2.47	2.47	2.47	1.92	2.47	2.47	2.47	3.22
7500	1.77	2.24	2.24	2.24	1.51	2.23	2.24	2.24	2.62
8000	1.51	2.04	2.04	2.04	1.22	1.85	2.04	2.04	2.16
8500	1.30	1.86	1.86	1.86	0.98	1.53	1.86	1.86	1.80
9000	1.12	1.71	1.71	1.71	0.79	1.25	1.71	1.71	1.52
9500	0.98	1.57	1.57	1.57	0.65	1.03	1.48	1.57	1.29
10000	0.86	1.45	1.45	1.45	0.53	0.86	1.29	1.43	1.11
10500	0.76	1.34	1.34	1.34	0.44	0.73	1.12	1.27	0.96
11000	0.67	1.23	1.24	1.24	0.37	0.62	0.98	1.13	0.83
11500	0.60	1.11	1.13	1.13	0.31	0.52	0.85	1.00	0.73
12000	0.53	1.01	1.04	1.04	0.27	0.45	0.74	0.89	0.64
12500	0.47	0.92	0.96	0.96	0.23	0.38	0.64	0.79	0.57

Span	Z 250 - 19								Def'n L/150
	Inward				Intward				
	0	1	2	3	0	1	2	3	
3000	13.68	13.68	13.68	13.68	13.68	13.68	13.68	13.68	53.90
3500	11.34	11.34	11.34	11.33	11.34	11.34	11.34	11.33	33.94
4000	9.57	9.57	9.57	9.57	9.57	9.57	9.57	9.57	22.74
4500	7.41	8.19	8.19	8.19	8.19	8.19	8.19	8.19	15.97
5000	5.73	7.09	7.09	7.09	7.09	7.09	7.09	7.09	11.64
5500	4.51	6.19	6.19	6.19	5.92	6.19	6.19	6.19	8.75
6000	3.63	5.45	5.45	5.45	4.46	5.45	5.45	5.45	6.74
6500	2.98	4.83	4.83	4.82	3.40	4.83	4.83	4.82	5.30
7000	2.49	4.31	4.31	4.31	2.59	3.95	4.31	4.31	4.24
7500	2.10	3.81	3.81	3.81	2.02	3.20	3.81	3.81	3.45
8000	1.80	3.35	3.35	3.35	1.60	2.59	3.35	3.35	2.84
8500	1.55	2.97	2.97	2.97	1.27	2.10	2.95	2.97	2.37
9000	1.34	2.65	2.65	2.65	1.03	1.72	2.54	2.65	2.00
9500	1.18	2.38	2.38	2.38	0.84	1.40	2.18	2.38	1.70
10000	1.03	2.14	2.14	2.14	0.69	1.16	1.87	2.14	1.46
10500	0.91	1.94	1.94	1.94	0.58	0.97	1.60	1.90	1.26
11000	0.80	1.77	1.77	1.77	0.48	0.82	1.38	1.67	1.09
11500	0.71	1.61	1.62	1.62	0.41	0.69	1.18	1.47	0.96
12000	0.63	1.47	1.49	1.49	0.35	0.58	1.02	1.29	0.84
12500	0.56	1.35	1.37	1.37	0.30	0.50	0.88	1.13	0.75

Span	Z 250 - 24								Def'n L/150
	Inward				Intward				
	0	1	2	3	0	1	2	3	
3000	18.91	18.91	18.91	18.91	18.91	18.91	18.91	18.91	70.19
3500	16.21	16.21	16.21	16.21	16.21	16.21	16.21	16.21	44.20
4000	11.97	14.18	14.18	14.18	14.18	14.18	14.18	14.18	29.61
4500	8.73	12.61	12.61	12.61	12.61	12.61	12.61	12.61	20.80
5000	6.61	11.34	11.34	11.34	10.71	11.34	11.34	11.34	15.16
5500	5.17	10.10	10.10	10.10	7.98	10.10	10.10	10.10	11.39
6000	4.15	8.48	8.48	8.48	5.92	8.19	8.48	8.48	8.77
6500	3.39	7.23	7.23	7.23	4.47	6.63	7.23	7.23	6.90
7000	2.82	6.18	6.23	6.23	3.38	5.40	6.23	6.23	5.53
7500	2.38	5.31	5.43	5.43	2.60	4.34	5.43	5.43	4.49
8000	2.03	4.61	4.77	4.77	2.04	3.48	4.70	4.77	3.70
8500	1.75	4.03	4.23	4.23	1.63	2.80	4.02	4.23	3.09
9000	1.52	3.55	3.77	3.77	1.32	2.28	3.46	3.77	2.60
9500	1.33	3.16	3.38	3.38	1.08	1.85	2.98	3.34	2.21
10000	1.17	2.82	3.05	3.05	0.90	1.52	2.55	2.93	1.90
10500	1.03	2.54	2.77	2.77	0.75	1.26	2.18	2.58	1.64
11000	0.92	2.29	2.52	2.52	0.63	1.05	1.86	2.27	1.42
11500	0.82	2.08	2.31	2.31	0.54	0.89	1.58	2.01	1.25
12000	0.73	1.89	2.12	2.12	0.46	0.76	1.36	1.76	1.10
12500	0.66	1.73	1.95	1.95	0.40	0.65	1.17	1.54	0.97



NOTE: All gauges of section Z250 require M12 grade 4.6 bolts unless indicated otherwise. Values shaded require M12 grade 8.8 bolts.

THREE LAPPED SPANS

Three lapped spans are continuous over three bays, supported at each end of the purlin and lapped over two internal supports.

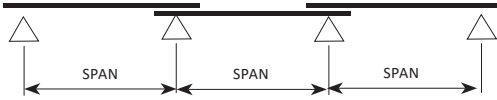

Span	Z 300 - 24								Def'n L/150
	Inward				Intward				
	0	1	2	3	0	1	2	3	
4000	16.92	16.92	16.91	16.92	16.92	16.92	16.92	16.92	51.29
4500	13.96	14.59	14.58	14.58	14.59	14.58	14.58	14.58	36.03
5000	10.39	12.70	12.70	12.70	12.70	12.70	12.70	12.70	26.26
5500	7.91	11.18	11.18	11.18	11.18	11.18	11.18	11.18	19.73
6000	6.21	9.91	9.90	9.91	9.91	9.91	9.90	9.91	15.20
6500	4.99	8.83	8.82	8.81	8.83	8.83	8.83	8.81	11.95
7000	4.10	7.92	7.92	7.92	7.11	7.92	7.92	7.92	9.57
7500	3.42	7.14	7.14	7.14	5.73	7.14	7.14	7.14	7.78
8000	2.89	6.47	6.46	6.46	4.65	6.45	6.46	6.46	6.41
8500	2.48	5.86	5.88	5.88	3.76	5.47	5.87	5.88	5.35
9000	2.14	5.14	5.31	5.31	3.05	4.65	5.31	5.31	4.50
9500	1.87	4.54	4.77	4.77	2.48	3.95	4.77	4.77	3.83
10000	1.64	4.03	4.31	4.31	2.04	3.36	4.31	4.31	3.28
10500	1.46	3.60	3.91	3.91	1.70	2.88	3.87	3.91	2.84
11000	1.30	3.24	3.56	3.56	1.42	2.47	3.43	3.56	2.47
11500	1.16	2.92	3.26	3.26	1.20	2.11	3.04	3.26	2.16
12000	1.05	2.65	2.99	2.99	1.03	1.81	2.70	2.99	1.90
12500	0.95	2.41	2.76	2.76	0.88	1.54	2.40	2.74	1.68
13000	0.86	2.20	2.55	2.55	0.76	1.33	2.14	2.47	1.49
13500	0.78	2.02	2.36	2.36	0.66	1.15	1.90	2.23	1.33
14000	0.71	1.86	2.20	2.20	0.58	1.00	1.69	2.02	1.20
14500	0.65	1.71	2.04	2.05	0.51	0.87	1.51	1.83	1.08
15000	0.60	1.58	1.89	1.91	0.45	0.76	1.35	1.66	0.97
15500	0.55	1.47	1.75	1.79	0.40	0.67	1.21	1.50	0.88
16000	0.51	1.36	1.63	1.68	0.35	0.60	1.08	1.36	0.80

Span	Z 300 - 30								Def'n L/150
	Inward				Intward				
	0	1	2	3	0	1	2	3	
4000	24.45	26.81	26.81	26.81	26.81	26.81	26.81	26.81	66.04
4500	16.89	23.83	23.83	23.83	23.83	23.83	23.83	23.83	46.38
5000	12.27	21.43	21.43	21.43	21.43	21.43	21.43	21.43	33.81
5500	9.27	18.64	18.64	18.64	18.64	18.64	18.64	18.64	25.40
6000	7.23	16.27	16.26	16.27	15.32	16.27	16.26	16.27	19.57
6500	5.78	14.25	14.29	14.28	12.36	14.30	14.29	14.28	15.39
7000	4.72	12.06	12.45	12.45	9.94	12.24	12.45	12.45	12.32
7500	3.93	10.31	10.85	10.85	7.90	10.38	10.85	10.85	10.02
8000	3.31	8.90	9.53	9.53	6.21	8.85	9.53	9.53	8.25
8500	2.83	7.75	8.45	8.44	4.93	7.58	8.44	8.44	6.88
9000	2.45	6.80	7.53	7.53	3.97	6.50	7.53	7.53	5.80
9500	2.14	6.00	6.76	6.76	3.24	5.55	6.70	6.76	4.93
10000	1.88	5.32	6.10	6.10	2.67	4.74	5.93	6.10	4.23
10500	1.66	4.73	5.50	5.53	2.22	3.99	5.27	5.53	3.65
11000	1.48	4.23	4.96	5.04	1.87	3.35	4.70	5.04	3.18
11500	1.33	3.80	4.50	4.61	1.59	2.82	4.20	4.55	2.78
12000	1.20	3.43	4.09	4.24	1.35	2.39	3.76	4.11	2.45
12500	1.08	3.11	3.73	3.91	1.17	2.04	3.36	3.73	2.16
13000	0.99	2.83	3.42	3.60	1.01	1.76	3.00	3.38	1.92
13500	0.90	2.58	3.14	3.31	0.88	1.52	2.68	3.08	1.72
14000	0.82	2.36	2.90	3.06	0.77	1.32	2.39	2.80	1.54
14500	0.76	2.16	2.68	2.83	0.68	1.16	2.10	2.56	1.39
15000	0.70	1.98	2.48	2.62	0.60	1.02	1.86	2.33	1.25
15500	0.64	1.83	2.30	2.44	0.54	0.90	1.63	2.11	1.14
16000	0.60	1.69	2.14	2.27	0.48	0.80	1.44	1.92	1.03

Where strength matters



NOTE: All gauges of section Z300 require M16 grade 4.6 bolts unless indicated otherwise. Values shaded require M16 grade 8.8 bolts.

THREE LAPPED SPANS

Three lapped spans are continuous over three bays, supported at each end of the purlin and lapped over two internal supports.

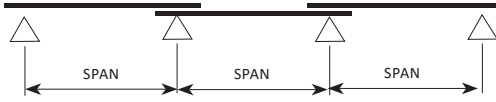

Where strength matters

Span	Z 350 - 24											
	Inward				Intward				Def'n L/150			
	0	1	2	3	0	1	2	3				
4000	15.33	15.33	15.32	15.33	15.33	15.33	15.33	15.33	82.26			
4500	13.39	13.38	13.38	13.38	13.39	13.39	13.38	13.38	57.78			
5000	11.81	11.81	11.81	11.81	11.81	11.81	11.81	11.81	42.12			
5500	10.53	10.53	10.53	10.53	10.53	10.53	10.53	10.53	31.65			
6000	8.85	9.45	9.44	9.45	9.45	9.45	9.44	9.45	24.37			
6500	7.06	8.53	8.52	8.51	8.53	8.53	8.52	8.51	19.17			
7000	5.75	7.74	7.74	7.74	7.74	7.74	7.74	7.74	15.35			
7500	4.79	7.06	7.06	7.06	7.06	7.06	7.06	7.06	12.48			
8000	4.06	6.47	6.46	6.46	6.47	6.47	6.46	6.46	10.28			
8500	3.47	5.94	5.93	5.94	5.94	5.94	5.93	5.94	8.57			
9000	2.99	5.47	5.47	5.47	5.47	5.47	5.47	5.47	7.22			
9500	2.60	5.06	5.06	5.06	4.64	5.06	5.06	5.06	6.14			
10000	2.28	4.69	4.69	4.69	3.88	4.69	4.69	4.69	5.27			
10500	2.01	4.36	4.35	4.36	3.26	4.36	4.35	4.36	4.55			
11000	1.79	4.06	4.06	4.05	2.77	4.01	4.05	4.05	3.96			
11500	1.59	3.73	3.79	3.79	2.37	3.57	3.79	3.79	3.46			
12000	1.43	3.39	3.54	3.54	2.04	3.19	3.54	3.54	3.05			
12500	1.29	3.09	3.32	3.32	1.77	2.85	3.32	3.32	2.70			
13000	1.17	2.83	3.11	3.12	1.56	2.52	2.08	3.11	2.40			
13500	1.06	2.60	2.92	2.92	1.37	2.21	2.82	2.92	2.14			
14000	0.97	2.39	2.71	2.72	1.20	1.94	2.58	2.72	1.92			
14500	0.89	2.21	2.51	2.53	1.06	1.71	2.36	2.53	1.73			
15000	0.82	2.05	2.33	2.37	0.94	1.51	2.17	2.34	1.56			
15500	0.75	1.90	2.17	2.22	0.83	1.35	2.00	2.17	1.41			
16000	0.70	1.77	2.03	2.08	0.73	1.20	1.84	2.01	1.29			

Span	Z 350 - 30											
	Inward				Intward				Def'n L/150			
	0	1	2	3	0	1	2	3				
4000	26.81	26.81	26.81	26.80	26.81	26.81	26.81	26.81	106.45			
4500	23.83	23.83	23.83	23.83	23.83	23.83	23.83	23.83	74.77			
5000	18.82	21.43	21.43	21.43	21.43	21.43	21.43	21.43	54.51			
5500	14.24	18.91	18.91	18.91	18.91	18.91	18.91	18.91	40.95			
6000	10.95	16.79	16.78	16.79	16.79	16.79	16.78	16.79	31.54			
6500	8.66	14.99	14.98	14.96	15.00	14.99	14.98	14.96	24.81			
7000	7.02	13.47	13.47	13.47	13.47	13.47	13.47	13.47	19.86			
7500	5.74	12.16	12.16	12.16	12.16	12.16	12.16	12.16	16.15			
8000	4.76	11.03	11.02	11.02	10.28	11.03	11.02	11.02	13.31			
8500	4.02	10.04	10.03	10.04	8.60	10.04	10.03	10.04	11.09			
9000	3.43	9.02	9.13	9.13	7.20	9.13	9.13	9.13	9.35			
9500	2.96	7.93	8.20	8.20	6.01	8.16	8.20	8.20	7.95			
10000	2.58	7.01	7.40	7.40	5.04	7.15	7.40	7.40	6.81			
10500	2.26	6.22	6.71	6.71	4.29	6.27	6.71	6.71	5.89			
11000	2.00	5.55	6.11	6.11	3.68	5.51	6.11	6.11	5.12			
11500	1.79	4.97	5.60	5.60	3.13	4.84	5.60	5.60	4.48			
12000	1.60	4.47	5.14	5.14	2.69	4.26	5.14	5.14	3.94			
12500	1.44	4.03	4.74	4.74	2.33	3.74	4.74	4.74	3.49			
13000	1.31	3.65	4.38	4.38	2.03	3.28	4.38	4.38	3.10			
13500	1.19	3.32	4.06	4.06	1.76	2.88	3.98	4.06	2.77			
14000	1.09	3.03	3.78	3.78	1.53	2.54	3.62	3.78	2.48			
14500	1.00	2.77	3.52	3.52	1.34	2.26	3.29	3.52	2.24			
15000	0.92	2.54	3.26	3.29	1.18	2.02	3.00	3.29	2.02			
15500	0.84	2.33	3.02	3.08	1.05	1.80	2.73	3.08	1.83			
16000	0.78	2.15	2.80	2.89	0.93	1.60	2.49	2.85	1.66			



NOTE: All gauges of section Z350 require M16 grade 4.6 bolts unless indicated otherwise. Values shaded require M16 grade 8.8 bolts.

THREE LAPPED SPANS

Three lapped spans are continuous over three bays, supported at each end of the purlin and lapped over two internal supports.

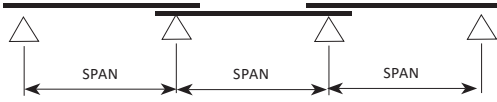

Span	Z 400 - 24								
	Inward				Intward				Def'n L/150
	0	1	2	3	0	1	2	3	
4000	13.72	13.72	13.71	13.72	13.72	13.72	13.71	13.72	110.35
4500	12.05	12.06	12.05	12.05	12.05	12.05	12.05	12.05	77.50
5000	10.71	10.71	10.71	10.71	10.71	10.71	10.71	10.71	56.50
5500	9.61	9.61	9.61	9.61	9.61	9.61	9.61	9.61	42.45
6000	8.69	8.69	8.68	8.69	8.69	8.69	8.68	8.69	32.70
6500	7.91	7.90	7.90	7.88	7.91	7.90	7.90	7.88	25.72
7000	6.59	7.22	7.22	7.22	7.22	7.22	7.22	7.22	20.59
7500	5.50	6.64	6.64	6.64	6.64	6.64	6.64	6.64	16.74
8000	4.65	6.12	6.11	6.11	6.12	6.12	6.11	6.11	13.79
8500	3.95	5.66	5.65	5.66	5.66	5.66	5.65	5.66	11.50
9000	3.40	5.25	5.25	5.25	5.25	5.25	5.25	5.25	9.69
9500	2.95	4.89	4.89	4.89	4.89	4.89	4.89	4.89	8.24
10000	2.59	4.56	4.56	4.56	4.46	4.56	4.56	4.56	7.06
10500	2.29	4.26	4.26	4.26	3.80	4.26	4.26	4.26	6.10
11000	2.03	3.99	3.99	3.98	3.22	3.99	3.99	3.98	5.31
11500	1.81	3.75	3.75	3.75	2.75	3.75	3.75	3.75	4.64
12000	1.62	3.52	3.53	3.52	2.37	3.52	3.53	3.52	4.09
12500	1.46	3.32	3.32	3.32	2.05	3.15	3.32	3.32	3.62
13000	1.32	3.13	3.13	3.13	1.80	2.81	3.13	3.13	3.21
13500	1.20	2.87	2.96	2.96	1.58	2.51	2.96	2.96	2.87
14000	1.10	2.64	2.80	2.80	1.39	2.25	2.80	2.80	2.57
14500	1.01	2.44	2.65	2.65	1.22	1.99	2.63	2.65	2.32
15000	0.92	2.25	2.51	2.51	1.08	1.76	2.42	2.51	2.09
15500	0.85	2.09	2.39	2.39	0.95	1.56	2.22	2.39	1.90
16000	0.79	1.94	2.26	2.27	0.85	1.39	2.04	2.24	1.72
16500	0.73	1.81	2.11	2.16	0.75	1.25	1.88	2.08	1.57
17000	0.68	1.69	1.98	2.06	0.67	1.12	1.73	1.93	1.44
17500	0.63	1.58	1.85	1.95	0.60	1.02	1.59	1.80	1.32
18000	0.59	1.48	1.74	1.83	0.54	0.93	1.46	1.67	1.21

Span	Z 400 - 30								
	Inward				Intward				Def'n L/150
	0	1	2	3	0	1	2	3	
4000	25.99	26.00	25.99	25.99	25.99	26.00	25.99		143.59
4500	22.68	22.68	22.67	22.67	22.68	22.67	22.67	22.66	100.85
5000	19.98	19.98	19.98	19.98	19.98	19.98	19.98	19.98	73.51
5500	16.51	17.79	17.79	17.79	17.79	17.79	17.79	17.79	55.23
6000	12.67	15.95	15.94	15.95	15.95	15.96	15.94	15.95	42.54
6500	10.02	14.38	14.37	14.34	14.39	14.38	14.37	14.35	33.46
7000	8.05	13.04	13.04	13.04	13.04	13.04	13.04	13.04	26.79
7500	6.57	11.88	11.88	11.87	11.88	11.88	11.88	11.88	21.78
8000	5.45	10.86	10.85	10.85	10.86	10.86	10.85	10.85	17.95
8500	4.58	9.97	9.96	9.97	9.96	9.97	9.96	9.97	14.96
9000	3.91	9.17	9.17	9.17	8.57	9.17	9.17	9.17	12.61
9500	3.37	8.47	8.47	8.47	7.13	8.47	8.47	8.47	10.72
10000	2.93	7.84	7.85	7.85	5.98	7.84	7.85	7.85	9.19
10500	2.57	7.28	7.28	7.28	5.08	7.28	7.28	7.28	7.94
11000	2.27	6.60	6.77	6.76	4.34	6.59	6.77	6.77	6.90
11500	2.02	5.90	6.32	6.32	3.69	5.79	6.32	6.32	6.04
12000	1.81	5.30	5.91	5.91	3.16	5.08	5.91	5.91	5.32
12500	1.63	4.77	5.47	5.47	2.73	4.45	5.47	5.47	4.71
13000	1.48	4.31	5.06	5.06	2.37	3.90	5.06	5.06	4.18
13500	1.34	3.91	4.69	4.69	2.05	3.41	4.64	4.69	3.74
14000	1.23	3.56	4.36	4.36	1.79	3.01	4.25	4.36	3.35
14500	1.12	3.25	4.06	4.07	1.57	2.67	3.90	4.07	3.01
15000	1.03	2.97	3.77	3.80	1.38	2.38	3.58	3.80	2.72
15500	0.95	2.72	3.50	3.56	1.22	2.12	3.27	3.56	2.47
16000	0.88	2.50	3.26	3.34	1.08	1.88	2.98	3.31	2.24
16500	0.82	2.31	3.04	3.14	0.96	1.68	2.71	3.07	2.05
17000	0.76	2.14	2.85	2.96	0.86	1.51	2.46	2.86	1.87
17500	0.71	1.99	2.67	2.79	0.77	1.36	2.24	2.66	1.72
18000	0.66	1.85	2.50	2.64	0.70	1.22	2.03	2.48	1.58

Where strength matters



NOTE: All gauges of section Z400 require M16 grade 4.6 bolts unless indicated otherwise. Values shaded require M16 grade 8.8 bolts.

FOUR LAPPED SPANS

Four lapped spans are continuous over four bays, supported at each end of the purlin and lapped over three internal supports.

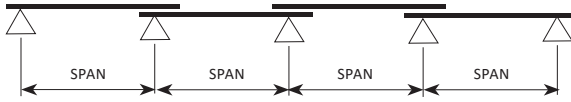

Where strength matters

Span	Z 100 - 10									
	Inward				Intward				Def'n L/150	
	0	1	2	3	0	1	2	3		
1500	9.35	9.35	9.34	9.34	9.35	9.35	9.34	9.34	22.04	
2000	6.21	6.21	6.21	6.21	6.21	6.21	6.21	6.21	9.30	
2500	4.29	4.29	4.29	4.29	4.29	4.29	4.29	4.29	4.76	
3000	2.98	2.98	2.98	2.98	2.90	2.98	2.98	2.98	2.75	
3500	2.15	2.19	2.19	2.19	1.90	2.19	2.19	2.19	1.74	
4000	1.60	1.68	1.68	1.68	1.25	1.64	1.68	1.68	1.16	
4500	1.23	1.33	1.33	1.33	0.83	1.19	1.33	1.33	0.82	
5000	0.96	1.07	1.07	1.07	0.58	0.86	1.07	1.07	0.60	
5500	0.77	0.89	0.89	0.89	0.42	0.62	0.87	0.89	0.45	
6000	0.62	0.75	0.75	0.75	0.32	0.46	0.68	0.75	0.34	
6500	0.50	0.64	0.64	0.64	0.24	0.35	0.54	0.62	0.27	
7000	0.41	0.55	0.55	0.55	0.18	0.27	0.43	0.51	0.22	
7500	0.34	0.48	0.48	0.48	0.14	0.21	0.34	0.42	0.18	
8000	0.28	0.42	0.42	0.42	0.11	0.17	0.27	0.34	0.15	

Span	Z 100 - 12									
	Inward				Intward				Def'n L/150	
	0	1	2	3	0	1	2	3		
1500	13.40	13.40	13.31	13.39	13.40	13.40	13.39	13.40	26.63	
2000	8.09	8.14	8.14	8.14	8.14	8.14	8.14	8.14	11.23	
2500	5.02	5.21	5.21	5.21	5.21	5.21	5.21	5.21	5.75	
3000	3.40	3.62	3.62	3.62	3.41	3.62	3.62	3.62	3.33	
3500	2.44	2.66	2.66	2.66	2.27	2.66	2.66	2.66	2.10	
4000	1.82	2.04	2.04	2.04	1.53	1.92	2.04	2.04	1.40	
4500	1.40	1.61	1.61	1.61	1.05	1.41	1.61	1.61	0.99	
5000	1.10	1.30	1.30	1.30	0.74	1.04	1.29	1.30	0.72	
5500	0.88	1.08	1.08	1.08	0.54	0.78	1.02	1.08	0.54	
6000	0.72	0.90	0.90	0.90	0.39	0.58	0.81	0.89	0.42	
6500	0.59	0.77	0.77	0.77	0.30	0.44	0.65	0.73	0.33	
7000	0.48	0.66	0.66	0.66	0.23	0.34	0.52	0.60	0.26	
7500	0.40	0.58	0.58	0.58	0.18	0.27	0.42	0.50	0.21	
8000	0.34	0.51	0.51	0.51	0.14	0.21	0.34	0.42	0.18	

Span	Z 100 - 15									
	Inward				Intward				Def'n L/150	
	0	1	2	3	0	1	2	3		
1500	18.19	18.19	18.19	18.19	18.19	18.19	18.19	18.19	33.91	
2000	9.86	10.60	10.60	10.60	10.60	10.60	10.60	10.60	14.30	
2500	6.13	6.79	6.79	6.79	6.60	6.79	6.79	6.79	7.32	
3000	4.16	4.71	4.71	4.71	4.31	4.71	4.71	4.71	4.24	
3500	2.99	3.46	3.46	3.46	2.94	3.34	3.46	3.46	2.67	
4000	2.24	2.65	2.65	2.65	2.07	2.44	2.65	2.65	1.79	
4500	1.74	2.09	2.09	2.09	1.45	1.82	2.06	2.09	1.26	
5000	1.38	1.70	1.70	1.70	1.01	1.39	1.62	1.70	0.92	
5500	1.11	1.40	1.40	1.40	0.73	1.06	1.29	1.37	0.69	
6000	0.91	1.18	1.18	1.18	0.54	0.81	1.04	1.12	0.53	
6500	0.76	1.00	1.00	1.00	0.41	0.61	0.85	0.93	0.42	
7000	0.63	0.85	0.87	0.87	0.32	0.47	0.70	0.77	0.33	
7500	0.53	0.73	0.75	0.75	0.25	0.37	0.57	0.65	0.27	
8000	0.44	0.63	0.66	0.66	0.20	0.29	0.47	0.55	0.22	

Span	Z 100 - 19									
	Inward				Intward				Def'n L/150	
	0	1	2	3	0	1	2	3		
1500	24.30	25.48	25.48	25.49	25.49	25.48	25.48	25.49	43.44	
2000	12.94	14.72	14.73	14.72	14.73	14.73	14.73	14.72	18.33	
2500	7.95	9.42	9.42	9.42	8.97	9.42	9.42	9.42	9.38	
3000	5.34	6.54	6.54	6.54	5.80	6.49	6.54	6.54	5.43	
3500	3.82	4.81	4.81	4.81	3.92	4.55	4.81	4.81	3.42	
4000	2.85	3.68	3.68	3.68	2.73	3.30	3.68	3.68	2.29	
4500	2.20	2.91	2.91	2.91	1.95	2.45	2.82	2.91	1.61	
5000	1.74	2.34	2.36	2.35	1.37	1.85	2.20	2.33	1.17	
5500	1.41	1.92	1.95	1.95	0.99	1.42	1.75	1.87	0.88	
6000	1.16	1.60	1.64	1.64	0.74	1.10	1.40	1.52	0.68	
6500	0.96	1.35	1.39	1.39	0.56	0.83	1.14	1.25	0.53	
7000	0.81	1.15	1.20	1.20	0.44	0.64	0.93	1.04	0.43	
7500	0.68	0.99	1.04	1.05	0.35	0.50	0.77	0.87	0.35	
8000	0.58	0.86	0.90	0.92	0.29	0.40	0.63	0.74	0.29	

Span	Z 100 - 24									
	Inward				Intward				Def'n L/150	
	0	1	2	3	0	1	2	3		
1500	30.89	32.33	32.32	32.33	32.33	32.33	32.32	32.33	54.21	
2000	16.35	18.97	18.97	18.97	18.91	18.97	18.97	18.97	22.87	
2500	9.96	12.21	12.21	12.21	11.50	12.21	12.21	12.21	11.71	
3000	6.67	8.48	8.48	8.48	7.53	8.28	8.48	8.48	6.78	
3500	4.75	6.15	6.23	6.23	5.09	5.85	6.23	6.23	4.27	
4000	3.54	4.66	4.77	4.77	3.56	4.29	4.69	4.77	2.86	
4500	2.73	3.65	3.77	3.77	2.54	3.20	3.61	3.75	2.01	
5000	2.17	2.93	3.05	3.05	1.84	2.42	2.84	2.97	1.46	
5500	1.75	2.41	2.52	2.52	1.35	1.86	2.27	2.40	1.10	
6000	1.44	2.01	2.10	2.12	1.02	1.44	1.83	1.97	0.85	
6500	1.20	1.70	1.78	1.81	0.79	1.12	1.49	1.63	0.67	
7000	1.01	1.46	1.53	1.56	0.63	0.88	1.22	1.36	0.53	
7500	0.86	1.27	1.33	1.35	0.51	0.70	1.01	1.14	0.43	
8000	0.74	1.10	1.16	1.18	0.42	0.56	0.83	0.96	0.36	

NOTE: All gauges of section Z100 require M12 grade 4.6 bolts unless indicated otherwise. Values shaded require M12 grade 8.8 bolts.



FOUR LAPPED SPANS

Four lapped spans are continuous over four bays, supported at each end of the purlin and lapped over three internal supports.

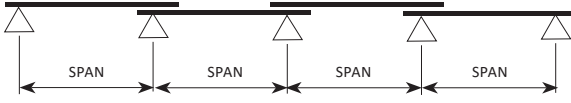

Span	Z 150 - 10									
	Inward				Intward				Def'n L/150	
	0	1	2	3	0	1	2	3		
2000	5.22	5.22	5.22	5.21	5.22	5.22	5.22	5.21	25.91	
2500	4.02	4.02	4.02	4.02	4.02	4.02	4.02	4.02	13.27	
3000	3.22	3.22	3.22	3.22	3.22	3.22	3.22	3.22	7.68	
3500	2.63	2.63	2.63	2.63	2.63	2.63	2.63	2.63	4.84	
4000	2.20	2.20	2.20	2.20	2.20	2.20	2.20	2.20	3.24	
4500	1.86	1.86	1.86	1.86	1.86	1.86	1.86	1.86	2.28	
5000	1.59	1.59	1.59	1.59	1.39	1.59	1.59	1.59	1.66	
5500	1.30	1.38	1.38	1.38	1.02	1.35	1.38	1.38	1.25	
6000	1.07	1.20	1.20	1.20	0.75	1.07	1.20	1.20	0.96	
6500	0.89	1.06	1.06	1.06	0.57	0.84	1.05	1.06	0.76	
7000	0.74	0.92	0.92	0.92	0.44	0.67	0.87	0.92	0.60	
7500	0.63	0.80	0.80	0.80	0.34	0.52	0.73	0.80	0.49	
8000	0.53	0.71	0.71	0.71	0.27	0.42	0.61	0.68	0.41	
8500	0.46	0.62	0.62	0.62	0.22	0.33	0.51	0.59	0.34	
9000	0.40	0.56	0.56	0.56	0.18	0.27	0.43	0.50	0.28	
9500	0.34	0.50	0.50	0.50	0.15	0.22	0.37	0.44	0.24	
10000	0.29	0.45	0.45	0.45	0.13	0.19	0.31	0.38	0.21	

Span	Z 150 - 12									
	Inward				Intward				Def'n L/150	
	0	1	2	3	0	1	2	3		
2000	8.53	8.53	8.53	8.53	8.53	8.53	8.53	8.53	32.20	
2500	6.42	6.42	6.42	6.42	6.42	6.42	6.42	6.42	16.49	
3000	5.01	5.01	5.01	5.01	5.01	5.01	5.01	5.01	9.54	
3500	4.01	4.01	4.01	4.01	4.01	4.01	4.01	4.01	6.01	
4000	3.28	3.28	3.28	3.28	3.28	3.28	3.28	3.28	4.03	
4500	2.54	2.72	2.72	2.72	2.47	2.72	2.72	2.72	2.83	
5000	2.00	2.24	2.24	2.24	1.78	2.24	2.24	2.24	2.06	
5500	1.61	1.85	1.85	1.85	1.28	1.78	1.85	1.85	1.55	
6000	1.31	1.56	1.56	1.56	0.94	1.40	1.56	1.56	1.19	
6500	1.08	1.33	1.33	1.33	0.71	1.09	1.33	1.33	0.94	
7000	0.90	1.14	1.14	1.14	0.56	0.84	1.14	1.14	0.75	
7500	0.76	1.00	1.00	1.00	0.44	0.66	0.96	1.00	0.61	
8000	0.64	0.88	0.88	0.88	0.35	0.52	0.81	0.88	0.50	
8500	0.54	0.78	0.78	0.78	0.28	0.42	0.67	0.77	0.42	
9000	0.47	0.69	0.69	0.69	0.23	0.35	0.56	0.66	0.35	
9500	0.40	0.62	0.62	0.62	0.19	0.29	0.46	0.57	0.30	
10000	0.35	0.56	0.56	0.56	0.16	0.24	0.39	0.49	0.26	

Span	Z 150 - 15									
	Inward				Intward				Def'n L/150	
	0	1	2	3	0	1	2	3		
2000	14.70	14.70	14.70	14.70	14.70	14.70	14.70	14.70	41.77	
2500	10.61	10.61	10.61	10.61	10.61	10.61	10.61	10.61	21.39	
3000	7.44	7.98	7.98	7.98	7.98	7.98	7.98	7.98	12.38	
3500	5.28	6.02	6.02	6.02	6.01	6.02	6.02	6.02	7.79	
4000	3.92	4.61	4.61	4.61	4.31	4.61	4.61	4.61	5.22	
4500	3.01	3.64	3.64	3.64	3.14	3.64	3.64	3.64	3.67	
5000	2.37	2.95	2.95	2.95	2.31	2.88	2.95	2.95	2.67	
5500	1.91	2.44	2.44	2.44	1.72	2.26	2.44	2.44	2.01	
6000	1.56	2.05	2.05	2.05	1.29	1.78	2.05	2.05	1.55	
6500	1.30	1.75	1.75	1.75	0.98	1.41	1.75	1.75	1.22	
7000	1.09	1.50	1.50	1.50	0.75	1.12	1.46	1.50	0.97	
7500	0.92	1.31	1.31	1.31	0.59	0.90	1.22	1.31	0.79	
8000	0.79	1.15	1.15	1.15	0.47	0.72	1.03	1.14	0.65	
8500	0.67	1.02	1.02	1.02	0.37	0.58	0.86	0.98	0.54	
9000	0.58	0.91	0.91	0.91	0.30	0.47	0.73	0.84	0.46	
9500	0.51	0.82	0.82	0.82	0.25	0.39	0.62	0.73	0.39	
10000	0.44	0.74	0.74	0.74	0.21	0.32	0.52	0.63	0.33	

Span	Z 150 - 19									
	Inward				Intward				Def'n L/150	
	0	1	2	3	0	1	2	3		
2000	24.08	24.13	24.13	24.13	24.13	24.14	24.13	24.13	53.48	
2500	14.59	16.51	16.51	16.51	16.51	16.51	16.51	16.51	27.38	
3000	9.68	11.56	11.56	11.56	11.56	11.56	11.56	11.56	15.85	
3500	6.84	8.50	8.50	8.50	8.09	8.50	8.50	8.50	9.98	
4000	5.06	6.51	6.51	6.51	5.84	6.51	6.51	6.51	6.69	
4500	3.85	5.14	5.14	5.14	4.31	5.01	5.14	5.14	4.70	
5000	3.01	4.16	4.16	4.16	3.21	3.90	4.16	4.16	3.42	
5500	2.40	3.44	3.44	3.44	2.36	3.08	3.44	3.44	2.57	
6000	1.95	2.89	2.89	2.89	1.74	2.45	2.85	2.89	1.98	
6500	1.61	2.46	2.46	2.46	1.32	1.97	2.36	2.46	1.56	
7000	1.35	2.10	2.12	2.12	1.01	1.57	1.97	2.11	1.25	
7500	1.14	1.82	1.85	1.85	0.79	1.24	1.66	1.79	1.01	
8000	0.97	1.59	1.63	1.63	0.62	0.98	1.41	1.54	0.84	
8500	0.84	1.40	1.44	1.44	0.50	0.80	1.20	1.33	0.70	
9000	0.72	1.24	1.28	1.28	0.41	0.64	1.02	1.15	0.59	
9500	0.63	1.11	1.15	1.15	0.34	0.53	0.86	1.00	0.50	
10000	0.55	0.99	1.04	1.04	0.29	0.43	0.73	0.87	0.43	

Span	Z 150 - 24									
	Inward				Intward				Def'n L/150	
	0	1	2	3	0	1	2	3		
2000	27.08	27.09	27.08	27.08	27.08	27.08	27.08	27.08	68.99	
2500	18.84	21.67	21.67	21.67	21.67	21.67	21.67	21.67	35.32	
3000	12.30	16.20	16.20	16.20	15.81	16.20	16.20	16.20	20.44	
3500	8.58	11.90	11.90	11.90	10.96	11.90	11.90	11.90	12.87	
4000	6.23	9.11	9.11	9.11	7.86	9.01	9.11	9.11	8.62	
4500	4.69	7.14	7.20	7.20	5.76	6.84	7.20	7.20	6.06	
5000	3.64	5.70	5.83	5.83	4.29	5.29	5.83	5.83	4.42	
5500	2.89	4.65	4.82	4.82	3.18	4.16	4.77	4.82	3.32	
6000	2.34	3.86	4.05	4.05	2.34	3.30	3.89	4.05	2.56	
6500	1.93	3.26	3.45	3.45	1.76	2.64	3.22	3.42	2.01	
7000	1.62	2.78	2.97	2.97	1.36	2.13	2.68	2.88	1.61	
7500	1.37	2.41	2.59	2.59	1.07	1.69	2.25	2.45	1.31	
8000	1.17	2.10	2.26	2.28	0.85	1.34	1.90	2.09	1.08	
8500	1.01	1.84	1.99	2.02	0.70	1.07	1.61	1.80	0.90	
9000	0.88	1.63	1.77	1.80	0.57	0.87	1.37	1.55	0.76	
9500	0.77	1.46	1.58	1.62	0.48	0.72	1.17	1.35	0.64	
10000	0.68	1.31	1.42	1.46	0.41	0.60	1.00	1.18	0.55	

NOTE: All gauges of section Z150 require M12 grade 4.6 bolts unless indicated otherwise. Values shaded require M12 grade 8.8 bolts.

Where strength matters



FOUR LAPPED SPANS

Four lapped spans are continuous over four bays, supported at each end of the purlin and lapped over three internal supports.

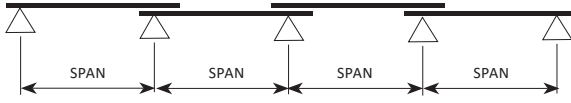

Where strength matters

Span	Z 200 - 12									
	Inward				Intward				Def'n L/150	
	0	1	2	3	0	1	2	3		
2500	5.34	5.34	5.34	5.34	5.34	5.34	5.34	5.34	34.67	
3000	4.34	4.34	4.34	4.34	4.34	4.34	4.34	4.34	20.07	
3500	3.61	3.61	3.61	3.61	3.61	3.61	3.61	3.61	12.64	
4000	3.06	3.07	3.06	3.07	3.06	3.07	3.06	3.06	8.47	
4500	2.63	2.63	2.63	2.63	2.63	2.63	2.63	2.63	5.95	
5000	2.29	2.29	2.29	2.29	2.29	2.29	2.29	2.29	4.33	
5500	2.01	2.01	2.01	2.01	2.01	2.01	2.01	2.01	3.26	
6000	1.75	1.78	1.77	1.78	1.69	1.78	1.77	1.78	2.51	
6500	1.46	1.58	1.58	1.58	1.33	1.58	1.58	1.58	1.97	
7000	1.23	1.41	1.41	1.41	1.06	1.40	1.41	1.41	1.58	
7500	1.05	1.27	1.27	1.27	0.84	1.16	1.27	1.27	1.28	
8000	0.90	1.15	1.15	1.15	0.67	0.95	1.15	1.15	1.06	
8500	0.78	1.04	1.04	1.04	0.54	0.79	1.02	1.04	0.88	
9000	0.68	0.95	0.95	0.95	0.44	0.66	0.88	0.95	0.74	
9500	0.60	0.86	0.86	0.86	0.37	0.56	0.77	0.84	0.63	
10000	0.53	0.78	0.78	0.78	0.31	0.47	0.67	0.74	0.54	
10500	0.47	0.70	0.70	0.70	0.26	0.39	0.58	0.66	0.47	
11000	0.42	0.64	0.64	0.64	0.22	0.33	0.50	0.58	0.41	
11500	0.37	0.59	0.59	0.59	0.19	0.28	0.44	0.52	0.36	
12000	0.33	0.53	0.54	0.54	0.16	0.24	0.38	0.46	0.31	

Span	Z 200 - 15									
	Inward				Intward				Def'n L/150	
	0	1	2	3	0	1	2	3		
2500	9.86	9.86	9.86	9.86	9.86	9.86	9.86	9.86	45.56	
3000	7.84	7.84	7.84	7.84	7.84	7.84	7.84	7.84	26.36	
3500	6.39	6.39	6.39	6.39	6.39	6.39	6.39	6.39	16.60	
4000	5.31	5.31	5.31	5.31	5.31	5.31	5.31	5.31	11.12	
4500	4.48	4.48	4.47	4.47	4.48	4.48	4.47	4.47	7.81	
5000	3.51	3.82	3.82	3.82	3.82	3.82	3.82	3.82	5.69	
5500	2.80	3.30	3.30	3.30	3.16	3.30	3.30	3.30	4.28	
6000	2.28	2.87	2.87	2.87	2.42	2.87	2.87	2.87	3.30	
6500	1.88	2.45	2.45	2.45	1.85	2.43	2.45	2.45	2.59	
7000	1.57	2.11	2.11	2.11	1.43	2.02	2.11	2.11	2.08	
7500	1.33	1.84	1.84	1.84	1.12	1.68	1.84	1.84	1.69	
8000	1.14	1.62	1.62	1.62	0.90	1.37	1.62	1.62	1.39	
8500	0.98	1.43	1.43	1.43	0.73	1.12	1.43	1.43	1.16	
9000	0.85	1.28	1.28	1.28	0.60	0.91	1.26	1.28	0.98	
9500	0.74	1.15	1.15	1.15	0.50	0.75	1.10	1.15	0.83	
10000	0.65	1.03	1.03	1.03	0.41	0.63	0.97	1.03	0.71	
10500	0.58	0.94	0.94	0.94	0.35	0.53	0.84	0.93	0.62	
11000	0.51	0.85	0.85	0.85	0.29	0.45	0.72	0.83	0.54	
11500	0.46	0.78	0.78	0.78	0.25	0.39	0.62	0.75	0.47	
12000	0.41	0.72	0.72	0.72	0.21	0.33	0.54	0.67	0.41	

Span	Z 200 - 19									
	Inward				Intward				Def'n L/150	
	0	1	2	3	0	1	2	3		
2500	18.48	18.48	18.48	18.48	18.48	18.48	18.47	18.48	60.83	
3000	14.36	14.36	14.36	14.36	14.36	14.36	14.36	14.36	35.20	
3500	10.37	11.45	11.45	11.44	11.45	11.45	11.45	11.45	22.17	
4000	7.53	9.33	9.32	9.33	9.32	9.33	9.32	9.33	14.85	
4500	5.68	7.66	7.66	7.66	7.50	7.66	7.66	7.66	10.43	
5000	4.41	6.20	6.20	6.20	5.71	6.20	6.20	6.20	7.60	
5500	3.51	5.13	5.13	5.13	4.39	5.13	5.13	5.13	5.71	
6000	2.85	4.31	4.31	4.31	3.40	4.28	4.31	4.31	4.40	
6500	2.36	3.67	3.67	3.67	2.65	3.49	3.67	3.67	3.46	
7000	1.98	3.16	3.16	3.16	2.07	2.86	3.16	3.16	2.77	
7500	1.68	2.76	2.76	2.76	1.63	2.36	2.76	2.76	2.25	
8000	1.43	2.42	2.42	2.42	1.30	1.95	2.42	2.42	1.86	
8500	1.24	2.15	2.15	2.15	1.05	1.61	2.10	2.15	1.55	
9000	1.07	1.91	1.91	1.91	0.86	1.33	1.81	1.91	1.30	
9500	0.94	1.72	1.72	1.72	0.70	1.11	1.57	1.72	1.11	
10000	0.83	1.55	1.55	1.55	0.58	0.93	1.36	1.53	0.95	
10500	0.73	1.40	1.41	1.41	0.49	0.77	1.18	1.35	0.82	
11000	0.65	1.27	1.28	1.28	0.41	0.65	1.03	1.19	0.71	
11500	0.58	1.16	1.17	1.17	0.35	0.56	0.90	1.06	0.63	
12000	0.53	1.05	1.08	1.08	0.30	0.48	0.78	0.94	0.55	

Span	Z 200 - 24									
	Inward				Intward				Def'n L/150	
	0	1	2	3	0	1	2	3		
2500	21.67	21.67	21.67	21.67	21.67	21.67	21.67	21.67	77.88	
3000	18.06	18.06	18.06	18.06	18.06	18.06	18.06	18.06	45.07	
3500	13.44	15.46	15.46	15.46	15.46	15.46	15.46	15.46	28.38	
4000	9.53	13.54	13.54	13.54	13.54	13.54	13.54	13.54	19.01	
4500	7.04	10.94	10.94	10.94	10.21	10.94	10.94	10.94	13.35	
5000	5.41	8.86	8.86	8.86	7.84	8.86	8.86	8.86	9.74	
5500	4.25	7.32	7.32	7.32	6.10	7.18	7.32	7.32	7.31	
6000	3.41	6.10	6.15	6.15	4.69	5.83	6.15	6.15	5.63	
6500	2.80	5.14	5.24	5.24	3.62	4.79	5.24	5.24	4.43	
7000	2.33	4.38	4.52	4.52	2.81	3.96	4.52	4.52	3.55	
7500	1.97	3.78	3.94	3.94	2.19	3.29	3.88	3.94	2.88	
8000	1.68	3.29	3.46	3.46	1.73	2.71	3.33	3.46	2.38	
8500	1.45	2.89	3.07	3.07	1.38	2.23	2.87	3.07	1.98	
9000	1.26	2.55	2.73	2.73	1.12	1.84	2.49	2.68	1.67	
9500	1.11	2.27	2.46	2.46	0.92	1.52	2.17	2.36	1.42	
10000	0.98	2.04	2.22	2.22	0.77	1.26	1.89	2.09	1.22	
10500	0.87	1.84	2.00	2.01	0.65	1.05	1.66	1.85	1.05	
11000	0.77	1.66	1.81	1.83	0.55	0.88	1.44	1.64	0.91	
11500	0.69	1.51	1.65	1.68	0.47	0.74	1.25	1.47	0.80	
12000	0.62	1.38	1.51	1.54	0.41	0.64	1.08	1.31	0.70	



FOUR LAPPED SPANS

Four lapped spans are continuous over four bays, supported at each end of the purlin and lapped over three internal supports.

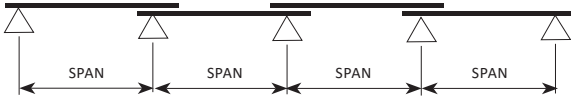

Span	Z 250 - 15								Def'n L/150
	Inward				Intward				
	0	1	2	3	0	1	2	3	
3000	6.84	6.84	6.84	6.84	6.84	6.84	6.84	6.84	44.52
3500	5.72	5.72	5.72	5.72	5.72	5.72	5.72	5.72	28.03
4000	4.88	4.88	4.88	4.88	4.88	4.88	4.88	4.88	18.78
4500	4.22	4.22	4.22	4.22	4.22	4.22	4.22	4.21	13.19
5000	3.69	3.69	3.69	3.69	3.69	3.69	3.69	3.69	9.62
5500	3.26	3.26	3.26	3.26	3.26	3.26	3.26	3.26	7.22
6000	2.90	2.90	2.89	2.90	2.90	2.90	2.89	2.90	5.57
6500	2.46	2.59	2.59	2.58	2.54	2.59	2.59	2.58	4.38
7000	2.08	2.33	2.33	2.33	2.01	2.33	2.33	2.33	3.50
7500	1.77	2.10	2.10	2.10	1.57	2.10	2.10	2.10	2.85
8000	1.51	1.91	1.91	1.91	1.26	1.82	1.91	1.91	2.35
8500	1.30	1.74	1.74	1.74	1.03	1.52	1.74	1.74	1.96
9000	1.13	1.59	1.59	1.59	0.84	1.28	1.59	1.59	1.65
9500	0.99	1.46	1.46	1.46	0.69	1.07	1.42	1.46	1.40
10000	0.87	1.34	1.34	1.34	0.57	0.88	1.24	1.34	1.20
10500	0.77	1.24	1.24	1.24	0.48	0.74	1.09	1.21	1.04
11000	0.68	1.14	1.14	1.14	0.40	0.63	0.96	1.08	0.90
11500	0.61	1.05	1.05	1.05	0.34	0.55	0.84	0.96	0.79
12000	0.55	0.95	0.96	0.96	0.29	0.47	0.74	0.86	0.70
12500	0.49	0.87	0.88	0.88	0.25	0.40	0.65	0.77	0.62

Span	Z 250 - 19								Def'n L/150
	Inward				Intward				
	0	1	2	3	0	1	2	3	
3000	13.18	13.18	13.19	13.18	13.18	13.18	13.19	13.18	58.62
3500	10.86	10.86	10.86	10.86	10.86	10.86	10.86	10.86	36.92
4000	9.12	9.13	9.12	9.13	9.12	9.13	9.12	9.13	24.73
4500	7.32	7.76	7.76	7.76	7.77	7.76	7.76	7.75	17.37
5000	5.65	6.69	6.69	6.69	6.69	6.69	6.69	6.69	12.66
5500	4.48	5.82	5.82	5.82	5.82	5.82	5.82	5.82	9.51
6000	3.64	5.10	5.10	5.10	4.56	5.10	5.10	5.10	7.33
6500	2.98	4.50	4.50	4.49	3.51	4.50	4.50	4.49	5.76
7000	2.49	4.00	4.00	4.00	2.73	3.87	4.00	4.00	4.62
7500	2.10	3.52	3.52	3.52	2.13	3.18	3.52	3.52	3.75
8000	1.79	3.09	3.09	3.09	1.69	2.61	3.09	3.09	3.09
8500	1.55	2.74	2.74	2.74	1.36	2.15	2.74	2.74	2.58
9000	1.35	2.44	2.44	2.44	1.10	1.76	2.44	2.44	2.17
9500	1.18	2.19	2.19	2.19	0.90	1.47	2.13	2.19	1.85
10000	1.04	1.98	1.98	1.98	0.74	1.21	1.84	1.98	1.58
10500	0.92	1.79	1.79	1.79	0.62	1.01	1.59	1.79	1.37
11000	0.82	1.63	1.63	1.63	0.52	0.85	1.38	1.61	1.19
11500	0.73	1.50	1.50	1.50	0.44	0.73	1.20	1.43	1.04
12000	0.66	1.37	1.37	1.37	0.38	0.62	1.04	1.27	0.92
12500	0.59	1.27	1.27	1.27	0.32	0.53	0.90	1.12	0.81

Span	Z 250 - 24								Def'n L/150
	Inward				Intward				
	0	1	2	3	0	1	2	3	
3000	18.06	18.06	18.06	18.06	18.06	18.06	18.06	18.06	76.35
3500	15.46	15.46	15.46	15.46	15.46	15.46	15.46	15.46	48.08
4000	11.92	13.54	13.54	13.54	13.54	13.54	13.54	13.54	32.21
4500	8.77	12.04	12.04	12.04	12.04	12.04	12.04	12.04	22.62
5000	6.67	11.26	11.26	11.26	10.45	11.26	11.26	11.26	16.49
5500	5.22	9.31	9.31	9.31	8.06	9.31	9.31	9.31	12.39
6000	4.18	7.83	7.83	7.83	6.13	7.83	7.83	7.83	9.54
6500	3.42	6.67	6.67	6.67	4.67	6.40	6.67	6.67	7.51
7000	2.85	5.75	5.75	5.75	3.60	5.26	5.75	5.75	6.01
7500	2.40	5.01	5.01	5.01	2.79	4.35	5.01	5.01	4.89
8000	2.05	4.38	4.40	4.40	2.19	3.55	4.40	4.40	4.03
8500	1.76	3.84	3.90	3.90	1.75	2.90	3.85	3.90	3.36
9000	1.53	3.39	3.48	3.48	1.41	2.36	3.33	3.48	2.83
9500	1.34	3.02	3.12	3.12	1.16	1.95	2.89	3.12	2.40
10000	1.18	2.70	2.82	2.82	0.96	1.60	2.51	2.80	2.06
10500	1.05	2.43	2.56	2.56	0.80	1.33	2.18	2.47	1.78
11000	0.93	2.20	2.33	2.33	0.68	1.11	1.88	2.19	1.55
11500	0.84	2.00	2.13	2.13	0.58	0.94	1.62	1.95	1.36
12000	0.75	1.82	1.96	1.96	0.50	0.80	1.39	1.73	1.19
12500	0.68	1.66	1.80	1.80	0.43	0.68	1.20	1.54	1.06

Where strength matters



NOTE: All gauges of section Z250 require M12 grade 4.6 bolts unless indicated otherwise. Values shaded require M12 grade 8.8 bolts.

FOUR LAPPED SPANS

Four lapped spans are continuous over four bays, supported at each end of the purlin and lapped over three internal supports.

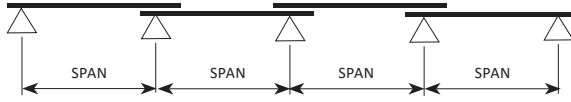

Where strength matters

Span	Z 300 - 24								
	Inward				Intward				Def'n L/150
	0	1	2	3	0	1	2	3	
4000	16.22	16.22	16.21	16.23	16.22	16.23	16.20	16.23	55.79
4500	13.82	13.91	13.91	13.90	13.92	13.91	13.91	13.90	39.18
5000	10.37	12.07	12.07	12.07	12.07	12.07	12.07	12.07	28.57
5500	8.00	10.57	10.57	10.57	10.57	10.57	10.57	10.57	21.46
6000	6.28	9.33	9.33	9.33	9.33	9.33	9.33	9.33	16.53
6500	5.04	8.29	8.28	8.27	8.29	8.29	8.28	8.27	13.00
7000	4.14	7.41	7.41	7.41	7.09	7.41	7.41	7.41	10.41
7500	3.45	6.65	6.65	6.65	5.78	6.65	6.65	6.65	8.46
8000	2.92	6.01	6.00	6.00	4.73	6.01	6.00	6.00	6.97
8500	2.50	5.45	5.44	5.45	3.89	5.31	5.44	5.45	5.81
9000	2.16	4.90	4.90	4.90	3.21	4.55	4.90	4.90	4.90
9500	1.89	4.34	4.40	4.40	2.65	3.91	4.40	4.40	4.17
10000	1.66	3.87	3.97	3.97	2.18	3.36	3.97	3.97	3.57
10500	1.47	3.46	3.60	3.60	1.82	2.88	3.60	3.60	3.08
11000	1.31	3.12	3.28	3.28	1.52	2.49	3.28	3.28	2.68
11500	1.17	2.82	3.00	3.00	1.29	2.16	2.93	3.00	2.35
12000	1.06	2.56	2.76	2.76	1.10	1.87	2.62	2.76	2.07
12500	0.95	2.33	2.54	2.54	0.94	1.62	2.34	2.54	1.83
13000	0.87	2.14	2.35	2.35	0.82	1.40	2.10	2.35	1.63
13500	0.79	1.96	2.18	2.18	0.71	1.21	1.88	2.15	1.45
14000	0.72	1.81	2.03	2.03	0.62	1.05	1.68	1.95	1.30
14500	0.66	1.67	1.89	1.89	0.55	0.92	1.51	1.78	1.17
15000	0.61	1.55	1.77	1.77	0.48	0.81	1.35	1.62	1.06
15500	0.56	1.44	1.65	1.65	0.43	0.71	1.22	1.47	0.96
16000	0.52	1.34	1.55	1.55	0.38	0.63	1.10	1.34	0.87

Span	Z 300 - 30								
	Inward				Intward				Def'n L/150
	0	1	2	3	0	1	2	3	
4000	24.78	25.60	25.60	25.60	25.60	25.60	25.60	25.60	71.82
4500	17.15	22.75	22.75	22.76	22.76	22.76	22.75	22.75	50.44
5000	12.45	20.13	20.13	20.13	20.13	20.13	20.13	20.13	36.77
5500	9.40	17.33	17.33	17.33	17.33	17.33	17.33	17.33	27.63
6000	7.32	15.06	15.06	15.06	14.70	15.07	15.06	15.06	21.28
6500	5.86	13.19	13.19	13.18	12.02	13.19	13.19	13.18	16.74
7000	4.78	11.37	11.48	11.48	9.86	11.48	11.48	11.48	13.40
7500	3.97	9.75	10.01	10.01	8.06	9.85	10.01	10.01	10.90
8000	3.35	8.44	8.80	8.80	6.56	8.44	8.80	8.80	8.98
8500	2.86	7.36	7.79	7.79	5.26	7.27	7.79	7.79	7.49
9000	2.47	6.47	6.95	6.95	4.24	6.29	6.95	6.95	6.31
9500	2.16	5.73	6.24	6.24	3.45	5.46	6.24	6.24	5.36
10000	1.90	5.10	5.63	5.63	2.85	4.71	5.61	5.63	4.60
10500	1.68	4.56	5.11	5.11	2.37	4.07	5.00	5.11	3.97
11000	1.50	4.11	4.65	4.65	2.00	3.50	4.47	4.65	3.45
11500	1.34	3.70	4.24	4.26	1.69	2.97	4.01	4.26	3.02
12000	1.21	3.35	3.86	3.91	1.45	2.53	3.60	3.88	2.66
12500	1.10	3.04	3.53	3.60	1.25	2.16	3.25	3.53	2.35
13000	1.00	2.78	3.23	3.33	1.08	1.86	2.93	3.21	2.09
13500	0.91	2.54	2.98	3.09	0.94	1.61	2.64	2.93	1.87
14000	0.83	2.33	2.75	2.87	0.83	1.40	2.37	2.68	1.68
14500	0.77	2.15	2.54	2.67	0.73	1.22	2.13	2.45	1.51
15000	0.71	1.99	2.36	2.48	0.64	1.07	1.91	2.25	1.36
15500	0.65	1.84	2.19	2.30	0.57	0.95	1.70	2.06	1.23
16000	0.60	1.71	2.04	2.15	0.51	0.84	1.51	1.88	1.12



NOTE: All gauges of section Z300 require M16 grade 4.6 bolts unless indicated otherwise. Values shaded require M16 grade 8.8 bolts.

FOUR LAPPED SPANS

Four lapped spans are continuous over four bays, supported at each end of the purlin and lapped over three internal supports.

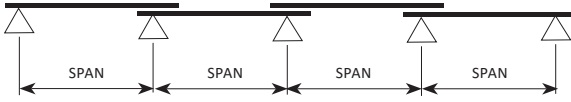

Span	Z 350 - 24								
	Inward				Intward				Def'n L/150
	0	1	2	3	0	1	2	3	
4000	14.85	14.86	14.84	14.86	14.85	14.86	14.84	14.86	89.47
4500	12.93	12.92	12.91	12.91	12.93	12.92	12.91	12.90	62.84
5000	11.37	11.37	11.37	11.37	11.37	11.37	11.37	11.37	45.81
5500	10.11	10.11	10.11	10.11	10.11	10.11	10.11	10.11	34.42
6000	8.82	9.04	9.03	9.04	9.04	9.04	9.03	9.04	26.51
6500	7.03	8.14	8.13	8.11	8.14	8.14	8.13	8.12	20.85
7000	5.72	7.36	7.36	7.36	7.36	7.36	7.36	7.36	16.70
7500	4.74	6.69	6.69	6.69	6.69	6.69	6.69	6.69	13.57
8000	3.99	6.11	6.10	6.10	6.11	6.11	6.10	6.10	11.19
8500	3.42	5.59	5.59	5.59	5.59	5.59	5.59	5.60	9.32
9000	2.96	5.14	5.14	5.14	5.14	5.14	5.14	5.14	7.86
9500	2.59	4.74	4.74	4.74	4.64	4.74	4.74	4.74	6.68
10000	2.27	4.38	4.38	4.38	4.01	4.38	4.38	4.38	5.73
10500	2.01	4.06	4.06	4.06	3.39	4.06	4.06	4.06	4.95
11000	1.78	3.77	3.77	3.77	2.88	3.77	3.77	3.77	4.30
11500	1.60	3.52	3.52	3.52	2.47	3.43	3.52	3.52	3.77
12000	1.44	3.22	3.28	3.28	2.12	3.08	3.28	3.28	3.31
12500	1.30	2.94	3.07	3.07	1.84	2.76	3.07	3.07	2.93
13000	1.18	2.69	2.87	2.88	1.60	2.49	2.87	2.88	2.61
13500	1.07	2.48	2.70	2.70	1.41	2.24	2.66	2.70	2.33
14000	0.98	2.28	2.51	2.51	1.25	1.99	2.44	2.51	2.09
14500	0.90	2.11	2.34	2.34	1.11	1.76	2.25	2.34	1.88
15000	0.82	1.96	2.18	2.18	0.99	1.56	2.07	2.18	1.70
15500	0.76	1.82	2.04	2.05	0.88	1.39	1.91	2.04	1.54
16000	0.70	1.70	1.91	1.92	0.79	1.24	1.76	1.90	1.40

Span	Z 350 - 30								
	Inward				Intward				Def'n L/150
	0	1	2	3	0	1	2	3	
4000	25.60	25.60	25.60	25.60	25.60	25.60	25.60	25.60	115.79
4500	22.76	22.76	22.75	22.76	22.75	22.76	22.76	22.75	81.32
5000	18.61	20.43	20.43	20.43	20.43	20.43	20.43	20.43	59.28
5500	14.13	17.93	17.93	17.93	17.93	17.93	17.93	17.93	44.54
6000	10.99	15.85	15.84	15.85	15.85	15.85	15.84	15.85	34.31
6500	8.67	14.10	14.09	14.07	14.10	14.10	14.09	14.07	26.98
7000	7.01	12.62	12.62	12.62	12.62	12.62	12.62	12.62	21.60
7500	5.78	11.35	11.35	11.35	11.35	11.35	11.35	11.35	17.57
8000	4.83	10.26	10.26	10.25	10.05	10.26	10.26	10.26	14.47
8500	4.07	9.31	9.31	9.32	8.51	9.31	9.31	9.32	12.07
9000	3.47	8.42	8.42	8.42	7.22	8.42	8.42	8.42	10.17
9500	2.99	7.56	7.56	7.56	6.13	7.56	7.56	7.56	8.64
10000	2.61	6.71	6.83	6.83	5.19	6.83	6.83	6.83	7.41
10500	2.29	5.98	6.19	6.19	4.39	6.06	6.19	6.19	6.40
11000	2.03	5.35	5.64	5.64	3.76	5.36	5.64	5.64	5.57
11500	1.81	4.81	5.16	5.16	3.25	4.75	5.16	5.16	4.87
12000	1.62	4.34	4.74	4.74	2.82	4.21	4.74	4.74	4.29
12500	1.46	3.93	4.37	4.37	2.44	3.74	4.37	4.37	3.79
13000	1.32	3.57	4.04	4.04	2.12	3.31	4.04	4.04	3.37
13500	1.20	3.26	3.75	3.75	1.85	2.94	3.75	3.75	3.01
14000	1.10	2.98	3.48	3.48	1.63	2.60	3.47	3.48	2.70
14500	1.01	2.73	3.25	3.25	1.43	2.30	3.17	3.25	2.43
15000	0.92	2.51	3.03	3.03	1.26	2.05	2.90	3.03	2.20
15500	0.85	2.32	2.84	2.84	1.12	1.84	2.66	2.84	1.99
16000	0.79	2.14	2.67	2.67	0.99	1.65	2.43	2.67	1.81

Where strength matters



NOTE: All gauges of section Z350 require M16 grade 4.6 bolts unless indicated otherwise. Values shaded require M16 grade 8.8 bolts.

FOUR LAPPED SPANS

Four lapped spans are continuous over four bays, supported at each end of the purlin and lapped over three internal supports.

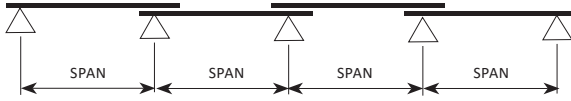

Where strength matters



Span	Z 400 - 24								
	Inward				Intward				Def'n L/150
	0	1	2	3	0	1	2	3	
4000	13.36	13.37	13.35	13.37	13.36	13.37	13.34	13.37	120.02
4500	11.72	11.71	11.70	11.69	11.72	11.71	11.70	11.69	84.29
5000	10.39	10.39	10.39	10.39	10.39	10.39	10.39	10.38	61.45
5500	9.30	9.30	9.30	9.30	9.30	9.30	9.30	9.30	46.17
6000	8.39	8.39	8.38	8.39	8.39	8.39	8.38	8.39	35.56
6500	7.61	7.61	7.60	7.59	7.61	7.61	7.60	7.59	27.97
7000	6.55	6.94	6.94	6.94	6.94	6.94	6.94	6.94	22.40
7500	5.42	6.36	6.36	6.36	6.36	6.36	6.36	6.36	18.21
8000	4.58	5.85	5.84	5.84	5.85	5.85	5.84	5.84	15.00
8500	3.92	5.40	5.39	5.40	5.39	5.40	5.39	5.40	12.51
9000	3.39	4.99	4.99	4.99	4.99	4.99	4.99	4.99	10.54
9500	2.95	4.64	4.64	4.64	4.64	4.64	4.64	4.64	8.96
10000	2.58	4.31	4.31	4.31	4.31	4.31	4.31	4.31	7.68
10500	2.28	4.02	4.02	4.02	3.84	4.02	4.02	4.02	6.64
11000	2.02	3.76	3.76	3.75	3.35	3.76	3.76	3.75	5.77
11500	1.81	3.52	3.52	3.52	2.87	3.52	3.52	3.52	5.05
12000	1.63	3.31	3.31	3.31	2.47	3.31	3.31	3.31	4.45
12500	1.47	3.11	3.11	3.10	2.14	3.07	3.11	3.10	3.93
13000	1.33	2.93	2.92	2.93	1.86	2.75	2.92	2.93	3.50
13500	1.21	2.75	2.76	2.76	1.63	2.47	2.76	2.76	3.12
14000	1.11	2.53	2.61	2.61	1.45	2.22	2.61	2.61	2.80
14500	1.01	2.34	2.46	2.46	1.29	2.00	2.46	2.46	2.52
15000	0.93	2.17	2.33	2.33	1.14	1.81	2.31	2.33	2.28
15500	0.86	2.01	2.21	2.21	1.01	1.61	2.13	2.21	2.06
16000	0.79	1.87	2.10	2.10	0.90	1.44	1.96	2.10	1.88
16500	0.74	1.75	1.99	2.00	0.81	1.29	1.81	1.97	1.71
17000	0.68	1.63	1.87	1.90	0.72	1.16	1.67	1.83	1.56
17500	0.64	1.53	1.75	1.81	0.65	1.04	1.55	1.71	1.43
18000	0.59	1.44	1.65	1.72	0.58	0.94	1.43	1.60	1.32

Span	Z 400 - 30								
	Inward				Intward				Def'n L/150
	0	1	2	3	0	1	2	3	
4000	25.16	25.17	25.14	25.17	25.16	25.18	25.14	25.18	156.18
4500	21.88	21.86	21.85	21.84	21.88	21.86	21.86	21.84	109.68
5000	19.22	19.22	19.22	19.22	19.22	19.22	19.22	19.22	79.96
5500	16.49	17.06	17.05	17.06	17.05	17.05	17.05	17.05	60.08
6000	12.71	15.24	15.22	15.24	15.24	15.24	15.22	15.24	46.27
6500	10.02	13.69	13.68	13.66	13.70	13.69	13.68	13.66	36.39
7000	8.09	12.37	12.37	12.37	12.37	12.37	12.37	12.37	29.14
7500	6.65	11.23	11.23	11.23	11.23	11.23	11.23	11.23	23.69
8000	5.51	10.24	10.23	10.23	10.24	10.24	10.23	10.23	19.52
8500	4.64	9.37	9.36	9.37	9.37	9.37	9.36	9.37	16.27
9000	3.95	8.60	8.60	8.60	8.60	8.60	8.60	8.60	13.71
9500	3.40	7.92	7.92	7.92	7.30	7.92	7.92	7.92	11.66
10000	2.96	7.32	7.32	7.32	6.17	7.32	7.32	7.32	10.00
10500	2.60	6.78	6.77	6.77	5.21	6.78	6.77	6.77	8.63
11000	2.30	6.28	6.29	6.28	4.46	6.29	6.29	6.28	7.51
11500	2.04	5.68	5.86	5.86	3.84	5.65	5.86	5.86	6.57
12000	1.83	5.15	5.46	5.46	3.32	5.04	5.46	5.46	5.78
12500	1.65	4.66	5.05	5.05	2.86	4.46	5.05	5.05	5.12
13000	1.49	4.23	4.67	4.67	2.49	3.95	4.67	4.67	4.55
13500	1.36	3.85	4.33	4.33	2.18	3.49	4.33	4.33	4.06
14000	1.24	3.52	4.03	4.03	1.91	3.08	4.02	4.03	3.64
14500	1.13	3.22	3.75	3.75	1.67	2.73	3.70	3.75	3.28
15000	1.04	2.96	3.51	3.51	1.47	2.43	3.41	3.51	2.96
15500	0.96	2.72	3.28	3.28	1.30	2.17	3.14	3.28	2.68
16000	0.89	2.51	3.08	3.08	1.16	1.95	2.91	3.08	2.44
16500	0.82	2.32	2.88	2.90	1.03	1.75	2.67	2.90	2.23
17000	0.77	2.15	2.69	2.73	0.92	1.57	2.44	2.71	2.03
17500	0.71	2.00	2.52	2.58	0.83	1.41	2.24	2.52	1.87
18000	0.67	1.86	2.37	2.44	0.75	1.27	2.05	2.36	1.71

NOTE: All gauges of section Z400 require M16 grade 4.6 bolts unless indicated otherwise. Values shaded require M16 grade 8.8 bolts.

THICKENED END SPANS

Thickened end spans have the end bays with greater thickness than the internal bays. They are supported at each end of the purlin and lapped over three or more internal supports.

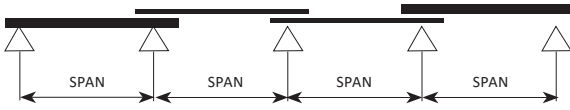

Span	Z 100 - 10 / 15								
	Inward				Intward				Def'n L/150
	0	1	2	3	0	1	2	3	
1500	10.23	10.22	10.22	10.23	10.23	10.22	10.22	10.23	32.11
2000	6.63	6.64	6.63	6.63	6.63	6.64	6.64	6.63	13.55
2500	4.50	4.50	4.50	4.50	4.50	4.50	4.50	4.50	6.94
3000	3.12	3.12	3.12	3.12	3.12	3.12	3.12	3.12	4.01
3500	2.26	2.29	2.29	2.29	2.27	2.29	2.29	2.29	2.53
4000	1.69	1.76	1.76	1.76	1.60	1.76	1.76	1.76	1.69
4500	1.30	1.39	1.39	1.39	1.15	1.39	1.39	1.39	1.19
5000	1.02	1.12	1.12	1.12	0.83	1.08	1.12	1.12	0.87
5500	0.81	0.93	0.93	0.93	0.60	0.93	0.93	0.93	0.65
6000	0.66	0.78	0.78	0.78	0.45	0.64	0.78	0.78	0.50
6500	0.54	0.67	0.67	0.67	0.35	0.50	0.66	0.67	0.40
7000	0.44	0.57	0.57	0.57	0.28	0.39	0.54	0.57	0.32
7500	0.36	0.50	0.50	0.50	0.23	0.31	0.45	0.50	0.26
8000	0.30	0.44	0.44	0.44	0.19	0.25	0.37	0.43	0.21

Span	Z 150 - 10 / 15								
	Inward				Intward				Def'n L/150
	0	1	2	3	0	1	2	3	
2000	5.94	5.94	5.94	5.94	5.94	5.94	5.94	5.94	38.96
2500	4.53	4.53	4.53	4.53	4.53	4.53	4.53	4.53	19.95
3000	3.58	3.58	3.58	3.58	3.58	3.58	3.58	3.58	11.54
3500	2.90	2.90	2.90	2.90	2.90	2.90	2.90	2.90	7.27
4000	2.39	2.39	2.39	2.39	2.39	2.39	2.39	2.39	4.87
4500	2.01	2.01	2.01	2.01	2.01	2.01	2.01	2.01	3.42
5000	1.70	1.70	1.70	1.70	1.70	1.70	1.70	1.70	2.49
5500	1.38	1.46	1.46	1.46	1.31	1.46	1.46	1.46	1.87
6000	1.13	1.27	1.27	1.27	1.02	1.26	1.27	1.27	1.44
6500	0.94	1.11	1.11	1.11	0.80	1.03	1.11	1.11	1.14
7000	0.79	0.96	0.96	0.96	0.62	0.84	0.96	0.96	0.91
7500	0.67	0.84	0.84	0.84	0.49	0.69	0.84	0.84	0.74
8000	0.57	0.74	0.74	0.74	0.39	0.57	0.72	0.74	0.61
8500	0.49	0.65	0.65	0.65	0.32	0.47	0.62	0.65	0.51
9000	0.42	0.58	0.58	0.58	0.27	0.39	0.54	0.58	0.43
9500	0.37	0.52	0.52	0.52	0.22	0.32	0.46	0.51	0.36
10000	0.32	0.47	0.47	0.47	0.19	0.27	0.40	0.45	0.31

Span	Z 100 - 12 / 19								
	Inward				Intward				Def'n L/150
	0	1	2	3	0	1	2	3	
1500	14.22	14.22	14.21	14.22	14.22	14.22	14.21	14.22	40.79
2000	8.57	8.57	8.57	8.57	8.57	8.57	8.57	8.57	17.21
2500	5.35	5.48	5.48	5.48	5.48	5.48	5.48	5.48	8.81
3000	3.63	3.81	3.81	3.81	3.81	3.81	3.81	3.81	5.10
3500	2.60	2.80	2.80	2.80	2.72	2.80	2.80	2.80	3.21
4000	1.95	2.14	2.14	2.14	1.96	2.14	2.14	2.14	2.15
4500	1.50	1.69	1.69	1.69	1.44	1.68	1.69	1.69	1.51
5000	1.18	1.37	1.37	1.37	1.08	1.30	1.37	1.37	1.10
5500	0.95	1.13	1.13	1.13	0.82	1.02	1.13	1.13	0.83
6000	0.77	0.95	0.95	0.95	0.63	0.81	0.95	0.95	0.64
6500	0.63	0.81	0.81	0.81	0.50	0.65	0.79	0.81	0.50
7000	0.53	0.70	0.70	0.70	0.40	0.53	0.66	0.70	0.40
7500	0.44	0.61	0.61	0.61	0.33	0.43	0.55	0.60	0.33
8000	0.37	0.54	0.54	0.54	0.27	0.35	0.47	0.52	0.27

Span	Z 150 - 12 / 19								
	Inward				Intward				Def'n L/150
	0	1	2	3	0	1	2	3	
2000	9.57	9.57	9.57	9.57	9.57	9.57	9.57	9.57	50.09
2500	7.10	7.09	7.09	7.09	7.10	7.09	7.09	7.10	25.65
3000	5.46	5.46	5.46	5.46	5.46	5.46	5.46	5.46	14.84
3500	4.32	4.32	4.32	4.32	4.32	4.32	4.32	4.32	9.35
4000	3.49	3.49	3.49	3.49	3.49	3.49	3.49	3.49	6.26
4500	2.72	2.88	2.87	2.87	2.88	2.88	2.87	2.87	4.40
5000	2.15	2.36	2.36	2.36	2.28	2.36	2.36	2.36	3.21
5500	1.73	1.95	1.95	1.95	1.77	1.95	1.95	1.95	2.41
6000	1.41	1.64	1.64	1.64	1.37	1.64	1.64	1.64	1.86
6500	1.17	1.40	1.40	1.40	1.06	1.38	1.40	1.40	1.46
7000	0.97	1.21	1.21	1.21	0.83	1.15	1.21	1.21	1.17
7500	0.82	1.05	1.05	1.05	0.66	0.95	1.05	1.05	0.95
8000	0.69	0.92	0.92	0.92	0.53	0.78	0.92	0.92	0.78
8500	0.59	0.82	0.82	0.82	0.44	0.64	0.82	0.82	0.65
9000	0.51	0.73	0.73	0.73	0.37	0.53	0.72	0.73	0.55
9500	0.44	0.66	0.66	0.66	0.31	0.44	0.63	0.66	0.47
10000	0.38	0.59	0.59	0.59	0.27	0.37	0.55	0.59	0.40

Span	Z 100 - 15 / 24								
	Inward				Intward				Def'n L/150
	0	1	2	3	0	1	2	3	
1500	18.99	18.98	18.98	18.99	18.99	18.89	18.98	18.99	51.24
2000	10.54	11.15	11.15	11.15	11.15	11.15	11.15	11.15	21.62
2500	6.56	7.14	7.14	7.14	7.14	7.14	7.14	7.14	11.07
3000	4.46	4.96	4.96	4.96	4.86	4.96	4.96	4.96	6.41
3500	3.21	3.64	3.64	3.64	3.43	3.64	3.64	3.64	4.03
4000	2.41	2.79	2.79	2.79	2.51	2.76	2.79	2.79	2.70
4500	1.87	2.20	2.20	2.20	1.89	2.11	2.20	2.20	1.90
5000	1.48	1.78	1.78	1.78	1.46	1.66	1.78	1.78	1.38
5500	1.20	1.48	1.48	1.48	1.15	1.32	1.46	1.48	1.04
6000	0.98	1.24	1.24	1.24	0.92	1.07	1.20	1.24	0.80
6500	0.82	1.06	1.06	1.06	0.73	0.88	1.00	1.05	0.63
7000	0.69	0.91	0.91	0.91	0.59	0.73	0.84	0.89	0.50
7500	0.58	0.78	0.79	0.79	0.48	0.61	0.72	0.76	0.41
8000	0.49	0.68	0.70	0.70	0.40	0.51	0.61	0.65	0.34

Span	Z 150 - 15 / 24								
	Inward				Intward				Def'n L/150
	0	1	2	3	0	1	2	3	
2000	16.02	16.02	16.02	16.02	16.02	16.02	16.02	16.02	64.89
2500	11.36	11.36	11.36	11.36	11.36	11.36	11.36	11.36	33.22
3000	8.03	8.43	8.43	8.43	8.43	8.43	8.43	8.43	19.23
3500	5.70	6.35	6.35	6.35	6.35	6.35	6.35	6.35	12.11
4000	4.24	4.86	4.86	4.86	4.86	4.86	4.86	4.86	8.11
4500	3.26	3.84	3.84	3.84	3.79	3.84	3.84	3.84	5.70
5000	2.57	3.11	3.11	3.11	2.92	3.11	3.11	3.11	4.15
5500	2.07	2.57	2.57	2.57	2.28	2.57	2.57	2.57	3.12
6000	1.70	2.16	2.16	2.16	1.81	2.16	2.16	2.16	2.40
6500	1.41	1.84	1.84	1.84	1.44	1.77	1.84	1.84	1.89
7000	1.19	1.59	1.59	1.59	1.16	1.47	1.59	1.59	1.51
7500	1.00	1.38	1.38	1.38	0.94	1.23	1.38	1.38	1.23
8000	0.86	1.22	1.22	1.22	0.77	1.03	1.22	1.22	1.01
8500	0.74	1.08	1.08	1.08	0.64	0.87	1.07	1.08	0.85
9000	0.64	0.96	0.96	0.96	0.53	0.73	0.93	0.96	0.71
9500	0.56	0.86	0.86	0.86	0.45	0.62	0.81	0.86	0.61
10000	0.49	0.78	0.78	0.78	0.38	0.53	0.71	0.77	0.52

NOTE: All gauges require M12 grade 4.6 bolts unless indicated otherwise. Values shaded require M12 grade 8.8 bolts.

Where strength matters



THICKENED END SPANS

Thickened end spans have the end bays with greater thickness than the internal bays. They are supported at each end of the purlin and lapped over three or more internal supports.

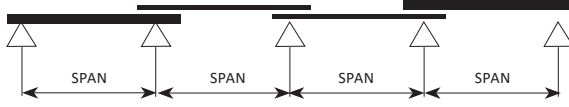

Where strength matters

Span	Z 200 - 12 / 19								
	Inward				Intward				Def'n L/150
	0	1	2	3	0	1	2	3	
2500	6.12	6.11	6.11	6.11	6.12	6.11	6.12	6.12	56.11
3000	4.93	4.93	4.93	4.93	4.93	4.93	4.93	4.93	32.47
3500	4.07	4.07	4.07	4.07	4.07	4.07	4.07	4.07	20.45
4000	3.42	3.42	3.42	3.41	3.42	3.42	3.42	3.41	13.70
4500	2.92	2.92	2.92	2.92	2.92	2.92	2.92	2.92	9.62
5000	2.52	2.51	2.51	2.52	2.52	2.51	2.51	2.52	7.01
5500	2.19	2.19	2.19	2.19	2.19	2.19	2.19	2.19	5.27
6000	1.88	1.92	1.92	1.92	1.92	1.92	1.92	1.92	4.06
6500	1.57	1.70	1.70	1.70	1.70	1.70	1.70	1.70	3.19
7000	1.32	1.51	1.51	1.51	1.41	1.51	1.51	1.51	2.56
7500	1.13	1.35	1.35	1.35	1.16	1.35	1.35	1.35	2.08
8000	0.97	1.22	1.22	1.22	0.95	1.20	1.22	1.22	1.71
8500	0.84	1.10	1.10	1.10	0.80	1.03	1.10	1.10	1.43
9000	0.73	1.00	1.00	1.00	0.67	0.89	1.00	1.00	1.20
9500	0.65	0.91	0.91	0.91	0.56	0.76	0.91	0.91	1.02
10000	0.57	0.82	0.82	0.82	0.47	0.66	0.81	0.82	0.88
10500	0.51	0.74	0.74	0.74	0.40	0.57	0.72	0.74	0.76
11000	0.45	0.68	0.68	0.68	0.34	0.49	0.64	0.68	0.66
11500	0.41	0.62	0.62	0.62	0.30	0.43	0.57	0.62	0.58
12000	0.36	0.57	0.57	0.57	0.26	0.38	0.51	0.56	0.51

Span	Z 250 - 15 / 24								
	Inward				Intward				Def'n L/150
	0	1	2	3	0	1	2	3	
3000	7.81	7.81	7.81	7.81	7.81	7.81	7.81	7.81	70.88
3500	6.49	6.49	6.49	6.49	6.49	6.49	6.49	6.49	44.64
4000	5.50	5.50	5.49	5.48	5.50	5.50	5.49	5.49	29.91
4500	4.72	4.72	4.72	4.71	4.72	4.72	4.72	4.72	21.00
5000	4.10	4.09	4.09	4.10	4.10	4.09	4.09	4.10	15.31
5500	3.59	3.59	3.59	3.59	3.59	3.59	3.59	3.59	11.50
6000	3.17	3.17	3.17	3.17	3.17	3.17	3.17	3.17	8.86
6500	2.64	2.82	2.81	2.81	2.82	2.82	2.81	2.81	6.97
7000	2.23	2.52	2.52	2.52	2.52	2.52	2.52	2.52	5.58
7500	1.91	2.26	2.26	2.26	2.14	2.26	2.26	2.26	4.54
8000	1.63	2.04	2.04	2.04	1.77	2.04	2.04	2.04	3.74
8500	1.41	1.85	1.85	1.85	1.48	1.85	1.85	1.85	3.12
9000	1.22	1.69	1.69	1.69	1.22	1.62	1.69	1.69	2.63
9500	1.07	1.54	1.54	1.54	1.02	1.40	1.54	1.54	2.23
10000	0.94	1.41	1.41	1.41	0.86	1.22	1.41	1.41	1.91
10500	0.83	1.30	1.30	1.30	0.73	1.06	1.29	1.30	1.65
11000	0.74	1.20	1.20	1.20	0.63	0.92	1.15	1.20	1.44
11500	0.66	1.10	1.10	1.10	0.54	0.81	1.04	1.10	1.26
12000	0.59	1.01	1.01	1.01	0.47	0.70	0.93	1.01	1.11
12500	0.53	0.93	0.93	0.93	0.41	0.60	0.84	0.91	0.98

Span	Z 200 - 15 / 24								
	Inward				Intward				Def'n L/150
	0	1	2	3	0	1	2	3	
2500	11.09	11.09	11.09	11.09	11.09	11.09	11.09	11.09	72.65
3000	8.72	8.72	8.72	8.72	8.72	8.72	8.72	8.72	42.04
3500	7.03	7.03	7.03	7.03	7.03	7.03	7.03	7.03	26.48
4000	5.78	5.78	5.78	5.77	5.78	5.78	5.78	5.77	17.74
4500	4.83	4.83	4.83	4.83	4.83	4.83	4.83	4.83	12.46
5000	3.83	4.08	4.08	4.09	4.09	4.08	4.08	4.09	9.08
5500	3.06	3.50	3.50	3.50	3.50	3.50	3.50	3.50	6.82
6000	2.49	3.02	3.02	3.03	3.02	3.02	3.02	3.03	5.26
6500	2.06	2.58	2.58	2.58	2.48	2.58	2.58	2.58	4.13
7000	1.72	2.23	2.23	2.23	2.06	2.23	2.23	2.23	3.31
7500	1.46	1.94	1.94	1.94	1.69	1.94	1.94	1.94	2.69
8000	1.25	1.71	1.71	1.71	1.38	1.71	1.71	1.71	2.22
8500	1.07	1.51	1.51	1.51	1.13	1.48	1.51	1.51	1.85
9000	0.93	1.35	1.35	1.35	0.93	1.29	1.35	1.35	1.56
9500	0.81	1.21	1.21	1.21	0.78	1.12	1.21	1.21	1.32
10000	0.71	1.09	1.09	1.09	0.66	0.97	1.09	1.09	1.14
10500	0.63	0.99	0.99	0.99	0.56	0.83	0.99	0.99	0.98
11000	0.56	0.90	0.90	0.90	0.48	0.71	0.90	0.90	0.85
11500	0.50	0.83	0.83	0.83	0.42	0.61	0.82	0.83	0.75
12000	0.45	0.76	0.76	0.76	0.37	0.53	0.74	0.76	0.66



NOTE: All gauges require M12 grade 4.6 bolts unless indicated otherwise. Values shaded require M12 grade 8.8 bolts.

HOOKFAST BRIDGING SYSTEM



Millform recently developed the **Hookfast**® bridging system to gain better control over key processes. We carry out all aspects of manufacturing, quality control, and delivery. This offers a range of benefits, with the lead time for bridging systems greatly reduced, the strength improved, and the packaging enhanced.

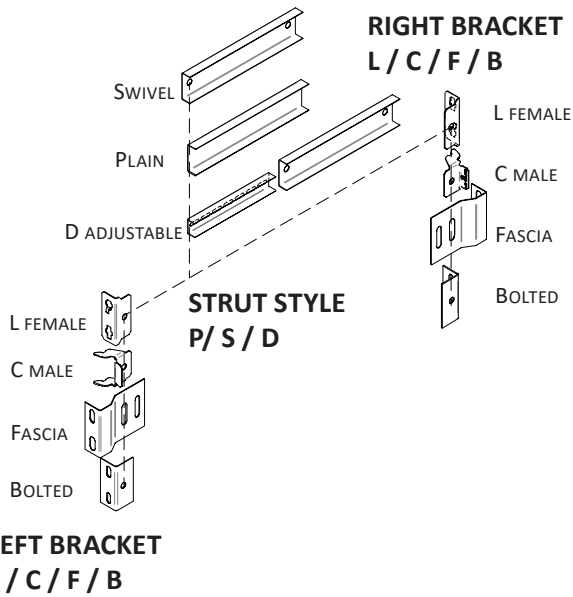

We spent considerable time researching and selecting the best riveting system available. We utilise the Henrob™ riveting system for a reliable and robust bridging solution. Henrob™ is owned and operated by a large and talented company dedicated to self-pierce riveting technology. This technology combines reliable design principles with robust production techniques.

Hookfast® bridging solutions offer a fast and simple installation process. Bridging is available in adjustable or fixed lengths, including Bolted Bracket and Fascia Clip designs with male or female Hookfast ends. We supply products in 40mm, 60mm, 70mm, 110mm and 160mm widths to suit purlins ranging from 100mm to 250mm in width. We also offer the standard speedy spacer system, which includes brackets and 12 mm diameter sag rods with threaded ends. Only Bolted Brackets 210mm are available for C/Z300.

BRIDGING CODING MILLFORM OCT 18

This document explains how the codes are interpreted for Hook lock bridging.

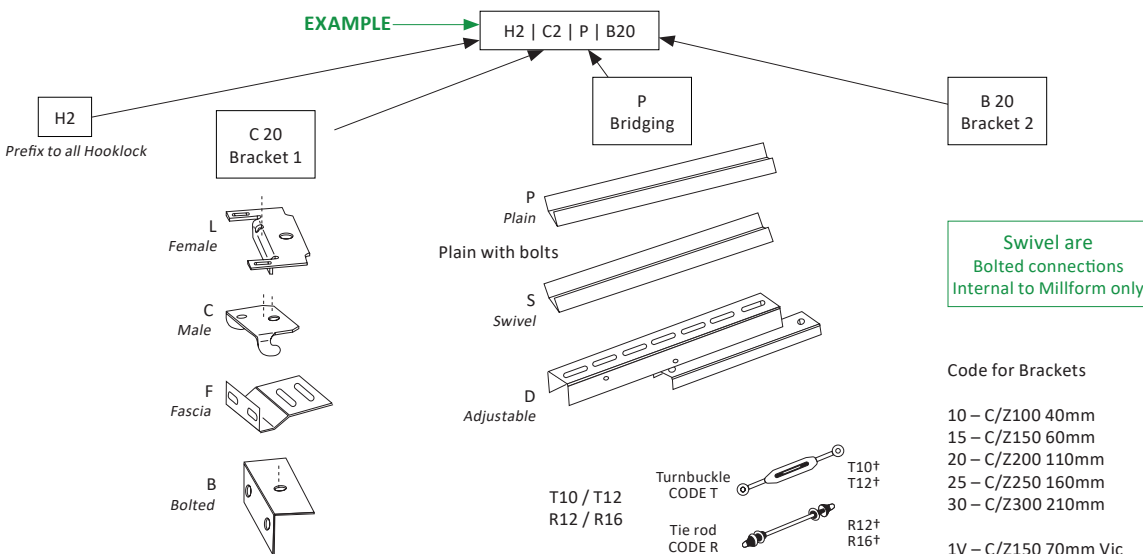

The Information contained in this document is proprietary to Millform Products and may not be copied, reproduced or disseminated in any form by any electronic or mechanical means without the express written permission Millform Products Management.

Where strength matters



FIND OUT MORE ABOUT OUR RANGE
OF STEEL BUILDING PRODUCTS

M **MILLFORM**
AUSTRALIA



TOPHAT & BATTENS



PURLIN & CHANNEL



HOOKFAST PURLIN BRIDGING SYSTEM



ROOFING & WALLING



ROOFING ACCESSORIES



JUNCTION STUD & FACADE SYSTEM



SLAB & SPIRAL DUCT

MILLFORM OFFICE & MANUFACTURING FACILITY

Sydney

22 Shale Place, Eastern Creek, NSW, 2766
Ph. (02) 9832 6900

Albury

101 Ceres Drive, Albury, NSW, 2640
Ph. (02) 6025 4377

REGIONAL SALES TEAMS

QLD, NSW, ACT, VIC, TAS, WA, NT

**FOR SALES AND INFORMATION ENQUIRIES, CONTACT OUR
KNOWLEDGEABLE TEAM**

Call: **1300 645 376** or email: enquiries@millform.com.au

www.millform.com.au

Version 2.2

All reasonable care has been taken to present accurate information at the time of publication. All recommendations related to the use of Millform products are made without a guarantee. Many factors are beyond our control, and all information presented is meant as a guide only. It is the customer's responsibility to ensure that all products are suitable for their intended purpose. Millform reserves the right to change product specifications and recommendations at any time without prior notice. The Millform logo is registered and protected under Australian law.

