



**MILLFORM
AUSTRALIA**

Where strength matters



Form **BATTEN**™
ROOF & CEILING BATTEN SYSTEM

TopForm™
TOP HAT SYSTEM

MILLFORM CEILING BATTEN, ROOF BATTEN & TOP-HAT PURLIN DESIGN & INSTALLATION GUIDE

CEILING BATTENS, ROOF BATTENS & TOP-HAT PURLINS



**MILLFORM
AUSTRALIA**

Where strength matters



With the strength of steel, Millform is dedicated to building a better Australia. We provide quality products, ensure efficient delivery standards, and offer proven solutions for commercial, construction, industrial, and government clients.

You can find other Millform items on our website.

www.millform.com.au



CONTENTS

PAGE

GENERAL INFORMATION

3

- Application 3
- Product Features and Benefits 3

DESIGN & SPECIFICATION

4

- Australian Standard 4
- Material Compatibility 4
- Welding Implication 4
- Cutting Implication 4
- Walking Consideration 4
- Batten Spacing Implication 4
- General Fixing Implication 4
- Potential Adverse Conditions 4
- On-Site Storage Considerations 4
- Good Practice 4
- Laps and Ends Considerations 4
- Allowance and Ends Considerations 4

PRODUCT RANGE & PROPERTIES

5

TOP-HAT PURLIN

7

- SPACING TABLES 50 – 120mm 7
- SINGLE, DOUBLE AND DOUBLE LAPPED SPANS 11
- PRODUCT DETAIL & INSTALLATION 12
- SPAN TABLES AS FLOOR JOISTS 14

CEILING BATTENS

15

- SPACING TABLES 22mm 15

ROOF BATTENS

16

- SPAN TABLES 40mm 16

Millform designs, manufactures, and sells high-quality **FormBatten™** ceiling battens, roof battens, and **TopForm™** top hats for residential, commercial, and industrial applications. All of our products are made from high-strength, high-durability, and high-tensile AZ150 Zincalume steel conforming to AS 1397.

Application

Millform **FormBatten™** ceiling battens, roof battens, and **TopForm™** top hats can be used in a wide array of residential, commercial, and industrial applications. These products are designed to function as a secondary member to support roof or wall cladding.

ROOF & CEILING BATTENS

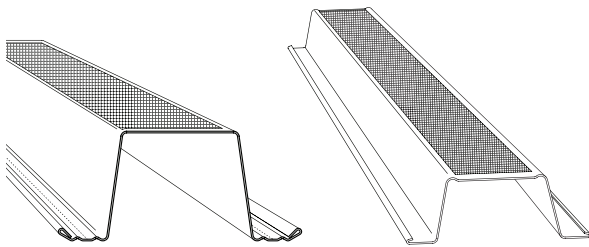

TOP-HATS

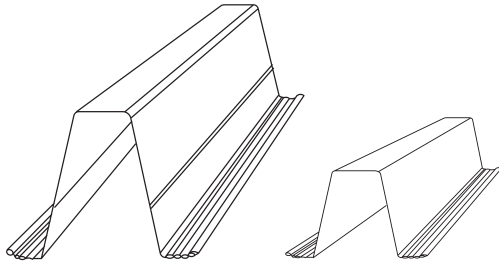

Product features and benefits:

- Extensive range of building applications
- Big spans allow for diverse installations
- Wide range of product gauges
- Simple and effective screw fasteners
- Fast and easy to install
- Available as Zincalume
- Largest range of products available
- Rolled safety edges are standard

Where strength matters





DESIGN & SPECIFICATION



Australian Standards

- AS 1170.0:2011, AS 1170.1:2002, and AS 1170.2:2011 - Loading Codes
- AS/NZS 4600:2018 - Cold-formed Steel Structures
- AS 3623:1993 - Domestic Metal Framing
- AS 1397:2011 - Steel Sheet & Strip - G550 MPa Steel
- AS 4055 - Wind Loads for Housing

Material Compatibility

Millform **FormBatten™** ceiling battens, roof battens, and **TopForm™** top hats should not be used together with bare metal, stainless steel, lead, copper, concrete, mortar, green, and some chemically treated timbers. Please contact Millform for more information.

Welding Implications

The heat produced from welding can affect the material properties of cold-formed steel products in some situations. In addition, it can remove galvanised coating and reduce material durability. Millform does not recommend welding ceiling battens, roof battens, or top hats.

Cutting Implications

Cutting can be applied, but abrasive discs should be avoided. If cutting is needed, Millform recommends the use of a power saw with a steel cutting blade or power nibbler.

Walking Considerations

- Ceiling battens should never be walked on or made to carry other loads.
- Roof battens and top hats can be walked on with care during installation and maintenance.

Batten Spacings Implications

Batten spacings need to be considered based on roof sheeting capacity, roof tile spacings, truss spacings, and plasterboard specifications. If local pressure factors are increased due to wind pressure, additional roof battens may be needed.

General Fixing Implications

Millform recommends fixing all ceiling battens, roof battens, and top hats according to the requirements of the design engineer. It is crucial to use correct fasteners and other components as

specified in this manual.

Potential Adverse Conditions

Local environmental conditions can impact site and material conditions, including corrosion and wind damage. If you plan to install **FormBatten™** ceiling battens, roof battens, and top hats within 1 km of corrosive, chemical, or industrial environments, please contact Millform.

On-site Storage Considerations

Millform **FormBatten™** ceiling battens, roof battens, and **TopForm™** top hats should be stored safely when they are not needed immediately. Stack all items off the ground, and for extended storage, use a small incline to prevent water from pooling. Materials should not be left exposed to open weather conditions for an extended period of time, with waterproof covers advised for moisture and rain protection.

Good Practice

Millform recommends following good trade practice as outlined in the Australian Standards Handbook HB 39.

Laps & Ends Considerations

For a lap to be considered as structural, a minimum overlap length of 15% of the span (support spacing) is needed. For instance, 7.5% at both ends is a common example. Two screws are needed at the support position, and an additional two screws are required 25-50 mm from both ends of the lap at the top of the web and bottom flange. This creates a total of 10 screws per lap.

For all top hat overlaps or non-structural laps, a minimum of 100 mm in length is recommended. In this situation, these laps should never be assumed to have structural continuity. When connecting overlapping top hats, it's essential to place the foot onto the upper section to nest sections both before and during the fixing process. Laps should be fastened through both webs.

Allowance at Ends Considerations

It is recommended that end fastenings are at least 25 mm from the section end. This is advised both at the structure end and at an internal support. When designing, purchasing, or installing materials, it's important to allow for this additional length over and above the span length and laps when specifying ordering or cutting sections.

PRODUCT RANGE & PROPERTIES



Top-Hat Purlin

50mm Top-Hat

50 mm TOP HAT - 0.75 BMT: **50TH0.75** (1.09kg/m)

50 mm TOP HAT - 0.95 BMT: **50TH0.95** (1.37kg/m)

50 mm TOP HAT - 1.15 BMT: **50TH1.15** (1.63kg/m)

Standard Pack: 100 Lengths

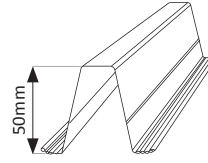

64mm Top-Hat

64 mm TOP HAT - 0.75 BMT: **64TH0.75** (1.26kg/m)

64 mm TOP HAT - 0.95 BMT: **64TH0.95** (1.58kg/m)

64 mm TOP HAT - 1.15 BMT: **64TH1.15** (1.91kg/m)

Standard Pack: 100 Lengths

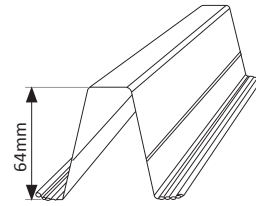

75mm Top-Hat

75 mm TOP HAT - 0.75 BMT: **75TH0.75** (1.41kg/m)

75 mm TOP HAT - 0.95 BMT: **75TH0.95** (1.77kg/m)

75 mm TOP HAT - 1.15 BMT: **75TH1.15** (2.14kg/m)

Standard Pack: 100 Lengths

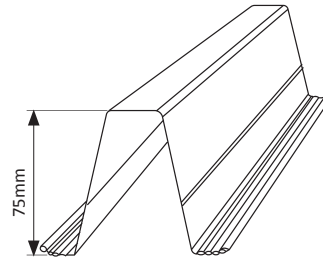

96mm Top-Hat

96 mm TOP HAT - 0.75 BMT: **96TH0.75** (1.74kg/m)

96 mm TOP HAT - 0.95 BMT: **96TH0.95** (2.19kg/m)

96 mm TOP HAT - 1.15 BMT: **96TH1.15** (2.65kg/m)

Standard Pack: 100 Lengths

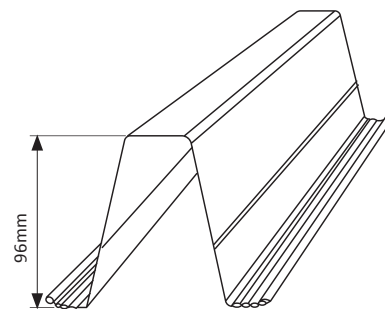

120mm Top-Hat

120 mm TOP HAT - 0.75 BMT: **120TH0.75** (2.17kg/m)

120 mm TOP HAT - 0.95 BMT: **120TH0.95** (2.73kg/m)

120 mm TOP HAT - 1.15 BMT: **120TH1.15** (3.30kg/m)

Standard Pack: 100 Lengths

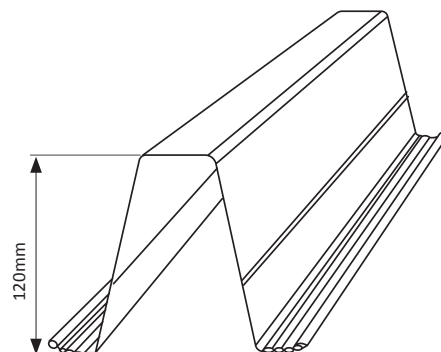

Where strength matters





Battens

22mm Ceiling Batten

22 mm CEILING BATTEN - 0.42 BMT - ALUZINC: **22CB0.42Z** (0.36kg/m)

22 mm CEILING BATTEN - 0.75 BMT - ALUZINC: **22CB0.75Z** (0.63kg/m)

Standard Pack: 200 Lengths (0.42) 100 Lengths (0.75) x 6.100M

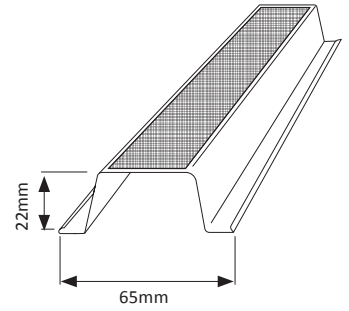

40mm Roof Batten*

40 mm ROOF BATTEN - 0.48 BMT - ALUZINC: **40RB0.48Z** (0.66kg/m)

40 mm ROOF BATTEN - 0.55 BMT - ALUZINC: **40RB0.55Z** (0.75kg/m)

Standard Pack: 150 Lengths x 6.100M, 7.500M

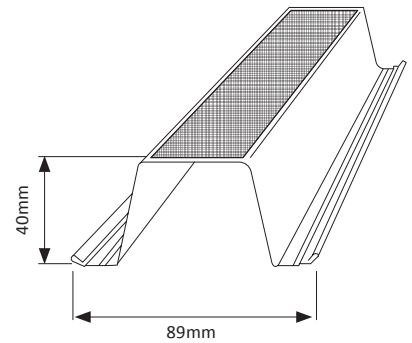

40mm Cyclonic Roof Batten*

40 mm ROOF BATTEN - 0.75 BMT - ALUZINC: **40RB0.75Z** (1.02kg/m)

Standard Pack: 100 Lengths x 6.100M, 7.500M

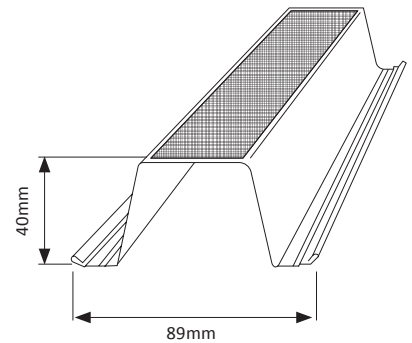

NOTE*: Standard Roof Battens are ANGLE CUT, SQUARE CUT ends would need to be requested.

Spacing Tables 50 – 120mm

TABLE 1		PURLIN SPACING												
Section 50 x 0.75	Load Type	600			900			1200			1500			
		MAX ALLOWABLE SPAN												
		SINGLE	DOUBLE	LAPPED	SINGLE	DOUBLE	LAPPED	SINGLE	DOUBLE	LAPPED	SINGLE	DOUBLE	LAPPED	
Strength Limit State	Inward Loads	2132	2366	2817	2024	2237	2644	1933	2130	2505	1856	2040	2389	
	Wind Loads	TC3	3779	4390	4854	3085	3585	3963	2672	3104	3432	2390	2777	3070
		TC2.5	3355	3898	4309	2739	3183	3519	2372	2756	3047	2122	2465	2726
		TC2	3021	3510	3881	2467	2866	3169	2136	2482	2744	1911	2220	2454
Serviceability Limit State	Span for LL defl. of Span/150	1749	2323	2495	1700	2258	2425	1658	2202	2366	1622	2153	2313	
	Span for LL defl. of Span/240	1495	1986	2134	1454	1931	2074	1418	1883	2023	1386	1841	1978	

TABLE 2		PURLIN SPACING												
Section 64 x 0.75	Load Type	600			900			1200			1500			
		MAX ALLOWABLE SPAN												
		SINGLE	DOUBLE	LAPPED	SINGLE	DOUBLE	LAPPED	SINGLE	DOUBLE	LAPPED	SINGLE	DOUBLE	LAPPED	
Strength Limit State	Inward Loads	2913	3221	3812	2731	3006	3530	2584	2835	3311	2462	2695	3133	
	Wind Loads	TC3	4518	5250	5804	3689	4286	4739	3195	3712	4104	2857	3320	3671
		TC2.5	4011	4661	5153	3275	3806	4207	2837	3296	3644	2537	2948	3259
		TC2	3612	4197	4640	2467	2950	3427	2554	2968	3281	2285	2655	2935
Serviceability Limit State	Span for LL defl. of Span/150	2340	3107	3338	2259	2999	3222	2191	2909	3125	2133	2832	3042	
	Span for LL defl. of Span/240	2001	2657	2854	1931	2564	2755	1873	2487	2672	1824	2422	2601	

TABLE 3		PURLIN SPACING												
Section 64 x 0.95	Load Type	600			900			1200			1500			
		MAX ALLOWABLE SPAN												
		SINGLE	DOUBLE	LAPPED	SINGLE	DOUBLE	LAPPED	SINGLE	DOUBLE	LAPPED	SINGLE	DOUBLE	LAPPED	
Strength Limit State	Inward Loads	3560	3927	4626	3307	3631	4245	3109	3402	3955	2947	3217	3725	
	Wind Loads	TC3	5085	5908	6532	4152	4824	5333	3596	4178	4619	3216	3737	4131
		TC2.5	4515	5246	5799	3686	4283	4735	3192	3709	4101	2855	3318	3668
		TC2	4066	4724	5222	3320	3857	4264	2875	3340	3693	2571	2988	3303
Serviceability Limit State	Span for LL defl. of Span/150	2687	3566	3831	2580	3425	3679	2493	3309	3555	2420	3212	3450	
	Span for LL defl. of Span/240	2297	3049	3276	2206	2928	3146	2131	2830	3040	2069	2747	2951	

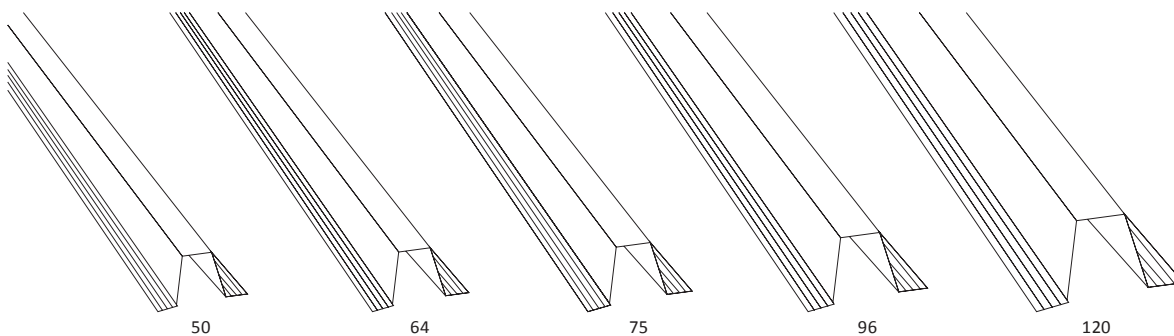

Where strength matters





Spacing Tables 50 – 120mm

TABLE 4		PURLIN SPACING												
Section 64 x 1.15	Load Type	600			900			1200			1500			
		MAX ALLOWABLE SPAN												
		SINGLE	DOUBLE	LAPPED	SINGLE	DOUBLE	LAPPED	SINGLE	DOUBLE	LAPPED	SINGLE	DOUBLE	LAPPED	
Strength Limit State	Inward Loads	4171	4590	5388	3846	4213	4907	3596	3927	4550	3396	3699	4268	
	Wind Loads	TC3	5595	6500	7186	4568	5308	5868	3956	4596	5082	3538	4111	4545
		TC2.5	4967	5771	6381	4056	4712	5210	3512	4081	4512	3142	3650	4035
		TC2	4473	5197	5746	3652	4244	4692	3163	3675	4063	2829	3287	3634
Serviceability Limit State	Span for LL defl. of Span/150	2997	3978	4273	2866	3804	4086	2761	3664	3936	2673	3548	3811	
	Span for LL defl. of Span/240	2563	3402	3654	2450	3253	3494	2360	3133	3366	2285	3034	3259	

TABLE 5		PURLIN SPACING												
Section 75 x 0.75	Load Type	600			900			1200			1500			
		MAX ALLOWABLE SPAN												
		SINGLE	DOUBLE	LAPPED	SINGLE	DOUBLE	LAPPED	SINGLE	DOUBLE	LAPPED	SINGLE	DOUBLE	LAPPED	
Strength Limit State	Inward Loads	3949	4349	5112	3651	4003	4668	3420	3738	4335	3234	3525	4072	
	Wind Loads	TC3	5412	6288	6952	4419	5134	5676	3827	4446	4916	3423	3977	4397
		TC2.5	4805	5583	6172	3923	4558	5040	3398	3948	4364	3039	3531	3904
		TC2	4327	5028	5558	3533	4105	4538	3060	3555	3930	2737	3180	3515
Serviceability Limit State	Span for LL defl. of Span/150	2980	3954	4248	2853	3787	4068	2751	3652	3923	2666	3539	3802	
	Span for LL defl. of Span/240	2548	3381	3633	2440	3238	3479	2352	3123	3355	2280	3026	3251	

TABLE 6		PURLIN SPACING												
Section 75 x 0.95	Load Type	600			900			1200			1500			
		MAX ALLOWABLE SPAN												
		SINGLE	DOUBLE	LAPPED	SINGLE	DOUBLE	LAPPED	SINGLE	DOUBLE	LAPPED	SINGLE	DOUBLE	LAPPED	
Strength Limit State	Inward Loads	4787	5259	6153	4385	4795	5567	4082	4449	5139	3841	4177	4805	
	Wind Loads	TC3	6091	7077	7824	4973	5778	6388	4307	5004	5532	3852	4476	4948
		TC2.5	5408	6283	6947	4416	5130	5672	3824	4443	4912	3420	3974	4393
		TC2	4870	5658	6256	3976	4620	5108	3444	4001	4423	3080	3579	3956
Serviceability Limit State	Span for LL defl. of Span/150	3405	4518	4854	3243	4304	4623	3115	4134	4441	3010	3994	4291	
	Span for LL defl. of Span/240	2911	3864	4151	2773	3680	3954	2664	3535	3798	2573	3416	3669	

The Following parameters have been used as the basis for the preparation of the following Tables

1. Loadings in accordance with AS 1170.1&2
2. Yield Strength of the Base Metal -
3. 550 mPa for BMI<1.0mm 350 mPa for BMI>1.0mm
4. Strength Calculations in Accordance with AS 4600 Cold Formed Steel Structures Code
5. The Base metal thickness (BMT) used as the basis of strength and stiffness
6. Lapped spans refers to total lap length of 1/4 of one span
7. For double and lapped spans the length of each span should not vary by more than 10% of the adjacent span
8. For normal roofing applications the maximum span should not exceed that specified for span/150 deflection criteria

Millform Products strongly recommends that the information in this publication is used in conjunction with a qualified Architect or Engineer.

Spacing Tables 50 – 120mm

TABLE 7		PURLIN SPACING												
Section 96 x 0.75	Load Type	600			900			1200			1500			
		MAX ALLOWABLE SPAN												
		SINGLE	DOUBLE	LAPPED	SINGLE	DOUBLE	LAPPED	SINGLE	DOUBLE	LAPPED	SINGLE	DOUBLE	LAPPED	
Strength Limit State	Inward Loads	5229	5737	6697	4769	5209	6035	4426	4819	5555	4156	4514	5184	
	Wind Loads	TC3	6437	7479	8269	5256	6107	6751	4552	5289	5847	4071	4730	5230
		TC2.5	5715	6641	7341	4667	5422	5994	4041	4696	5191	3615	4200	4643
		TC2	5147	5980	6611	4202	4883	5398	3639	4229	4675	3255	3782	4181
Serviceability Limit State	Span for LL defl. of Span/150	3940	5227	5616	3743	4967	5335	3589	4762	5116	3463	4595	4936	
	Span for LL defl. of Span/240	3369	4470	4802	3200	4247	4562	3069	4072	4375	2961	3929	4221	

TABLE 8		PURLIN SPACING												
Section 96 x 0.95	Load Type	600			900			1200			1500			
		MAX ALLOWABLE SPAN												
		SINGLE	DOUBLE	LAPPED	SINGLE	DOUBLE	LAPPED	SINGLE	DOUBLE	LAPPED	SINGLE	DOUBLE	LAPPED	
Strength Limit State	Inward Loads	6289	6882	7998	5685	6193	7145	5243	5695	6539	4901	5311	6077	
	Wind Loads	TC3	7245	8418	9306	5915	6873	7598	5123	5952	6580	4582	5324	5886
		TC2.5	6432	7474	8263	5252	6102	6746	4548	5285	5842	4068	4727	5226
		TC2	5793	6730	7441	4730	5495	6075	4096	4759	5261	3664	4257	4706
Serviceability Limit State	Span for LL defl. of Span/150	4482	5946	6387	4235	5618	6035	4045	5366	5765	3891	5163	5546	
	Span for LL defl. of Span/240	3832	5084	5462	3621	4804	5161	3458	4589	4930	3327	4415	4743	

TABLE 9		PURLIN SPACING												
Section 96 x 1.15	Load Type	600			900			1200			1500			
		MAX ALLOWABLE SPAN												
		SINGLE	DOUBLE	LAPPED	SINGLE	DOUBLE	LAPPED	SINGLE	DOUBLE	LAPPED	SINGLE	DOUBLE	LAPPED	
Strength Limit State	Inward Loads	7273	7942	9197	6527	7096	8161	5992	6496	7436	5581	6038	6889	
	Wind Loads	TC3	7971	9261	10239	6508	7562	8360	5636	6549	7240	5041	5857	6476
		TC2.5	7077	8223	9091	5778	6714	7423	5004	5814	6428	4476	5201	5750
		TC2	6373	7405	8186	5204	6046	6684	4507	5236	5789	4031	4683	5178
Serviceability Limit State	Span for LL defl. of Span/150	4962	6582	7071	4668	6192	6652	4445	5897	6335	4267	5661	6081	
	Span for LL defl. of Span/240	4243	5629	6047	3991	5295	5688	3801	5043	5417	3648	4841	5200	

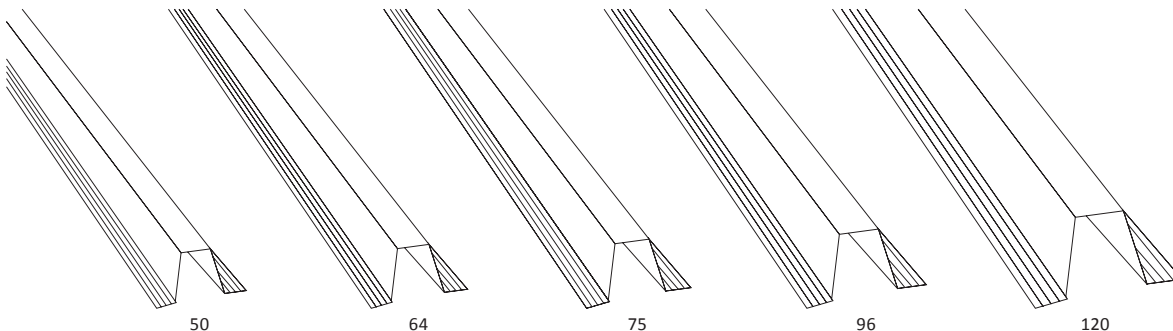

Where strength matters

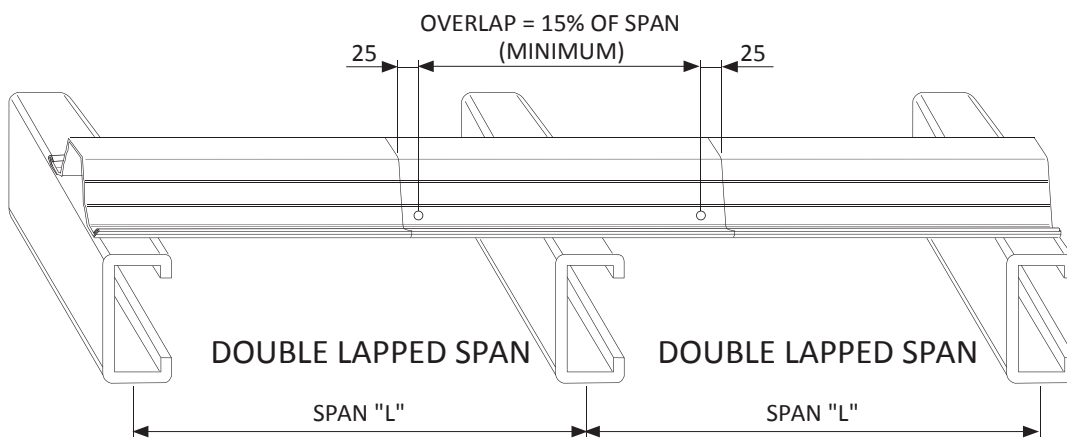
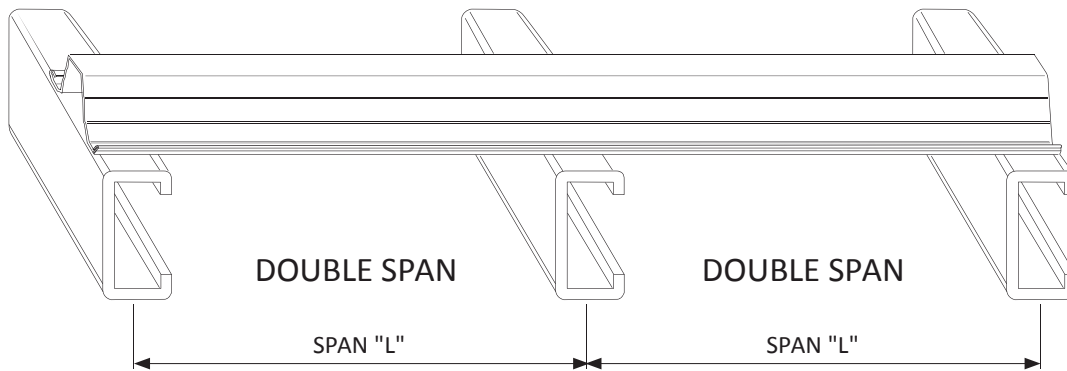
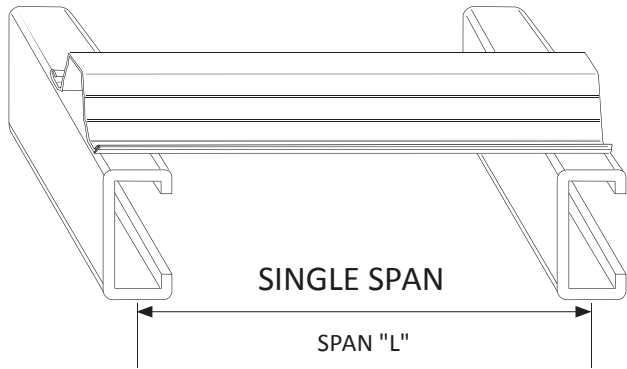

TABLE 10		PURLIN SPACING												
Section 120 x 0.75	Load Type	600			900			1200			1500			
		MAX ALLOWABLE SPAN												
		SINGLE	DOUBLE	LAPPED	SINGLE	DOUBLE	LAPPED	SINGLE	DOUBLE	LAPPED	SINGLE	DOUBLE	LAPPED	
Strength Limit State	Inward Loads	7724	8426	9744	6911	7508	8622	6332	6860	7842	5890	6368	7257	
	Wind Loads	TC3	8298	9641	10658	6775	7872	8703	5867	6817	7537	5248	6097	6741
		TC2.5	7367	8560	9463	6015	6989	7727	5209	6053	6692	4659	5414	5985
		TC2	6634	7708	8522	5417	6294	6958	4691	5451	6026	4196	4875	5390
Serviceability Limit State	Span for LL defl. of Span/150	5612	7443	7996	5270	6990	7509	5012	6648	7142	4808	6376	6849	
	Span for LL defl. of Span/240	4798	6365	6838	4505	5977	6421	4285	5685	6107	4109	5452	5857	

TABLE 11		PURLIN SPACING												
Section 120 x 0.95	Load Type	600			900			1200			1500			
		MAX ALLOWABLE SPAN												
		SINGLE	DOUBLE	LAPPED	SINGLE	DOUBLE	LAPPED	SINGLE	DOUBLE	LAPPED	SINGLE	DOUBLE	LAPPED	
Strength Limit State	Inward Loads	9186	9996	11512	8151	8834	10108	7427	8029	9149	6881	7425	8436	
	Wind Loads	TC3	9339	10851	11996	7625	8859	9794	6603	7672	8482	5906	6862	7587
		TC2.5	8291	9634	10651	6770	7866	8696	5863	6812	7531	5244	6093	6736
		TC2	7467	8676	9591	6097	7084	7831	5280	6135	6782	4722	5487	6066
Serviceability Limit State	Span for LL defl. of Span/150	6340	8408	9033	5922	7854	8437	5612	7444	7996	5368	7120	7648	
	Span for LL defl. of Span/240	5421	7190	7724	5063	6716	7215	4798	6365	6838	4589	6088	6540	



Single, Double and Double Lapped Spans



Where strength matters





Product Detail and Installation

50 TOP HAT

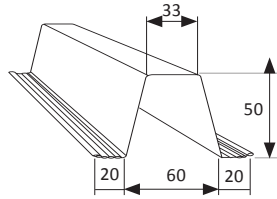

64 TOP HAT

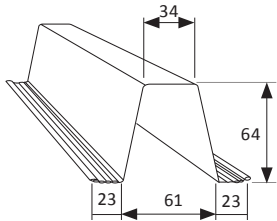

75 TOP HAT

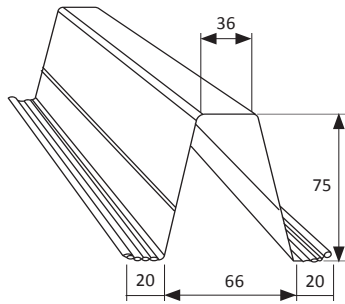

96 TOP HAT

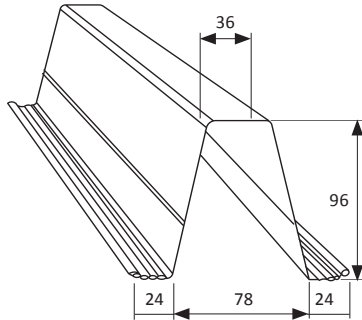

120 TOP HAT

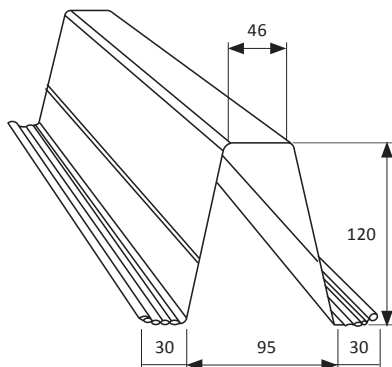

FASTENING STEEL CLADDING

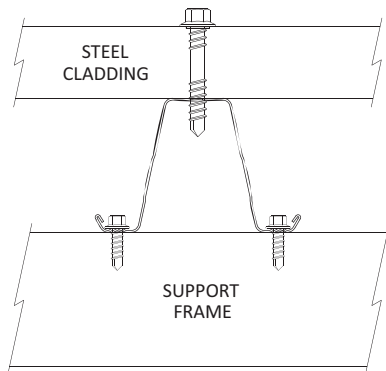

TYPICAL ATTACHMENT DETAIL 50, 64 & 75 TOP HAT LAPPED SECTION

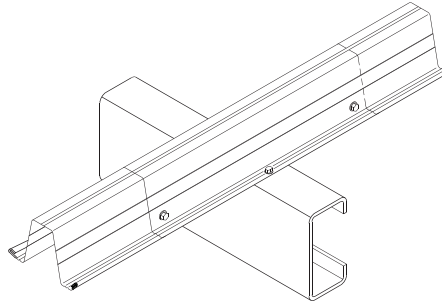

TYPICAL END ATTACHMENT DETAIL

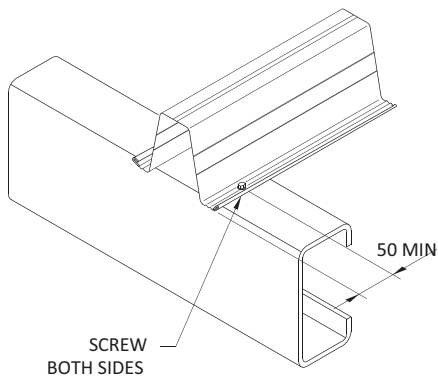

TYPICAL ATTACHMENT DETAIL 96 & 120 TOP HAT LAPPED SECTION

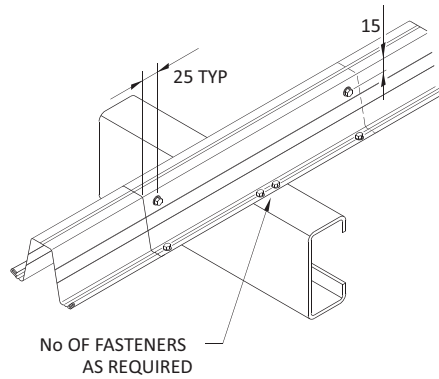

TOP HAT TYPICAL APPLICATION

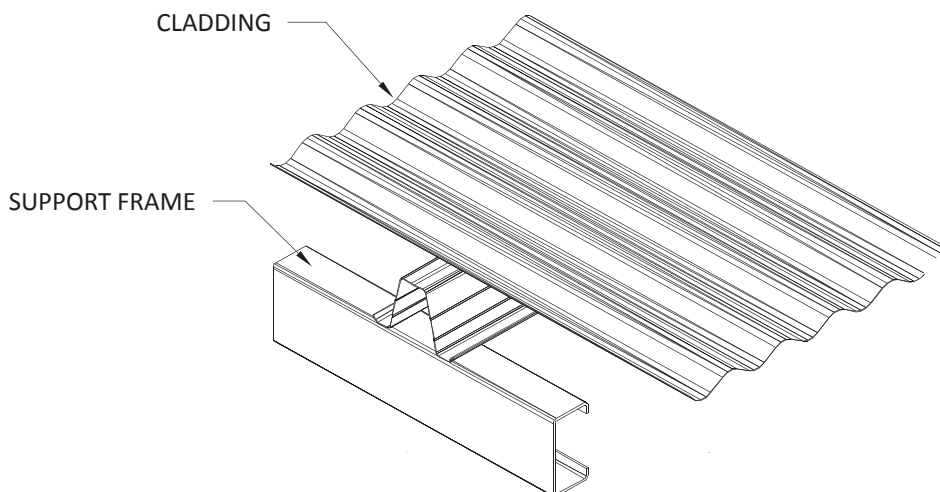

Where strength matters



600 SPACING

Floor Live Load	1.50	2.00	3.00	4.00	5.00
Spacing	600	600	600	600	600
Max Allowable Span					
Single Span	2432	2210	1930	1754	1628
Double Span	3260	2962	2588	2351	2182
Lapped Span 0.25L	3322	3018	2637	2396	2224
Lapped Span 0.50L	3473	3473	3473	3473	3473

450 SPACING

Floor Live Load	1.50	2.00	3.00	4.00	5.00
Spacing	450	450	450	450	450
Max Allowable Span					
Single Span	2677	2432	2125	1930	1792
Double Span	3588	3260	2848	2588	2402
Lapped Span 0.25L	3657	3322	2902	2637	2448
Lapped Span 0.50L	3823	3823	3823	3823	3823

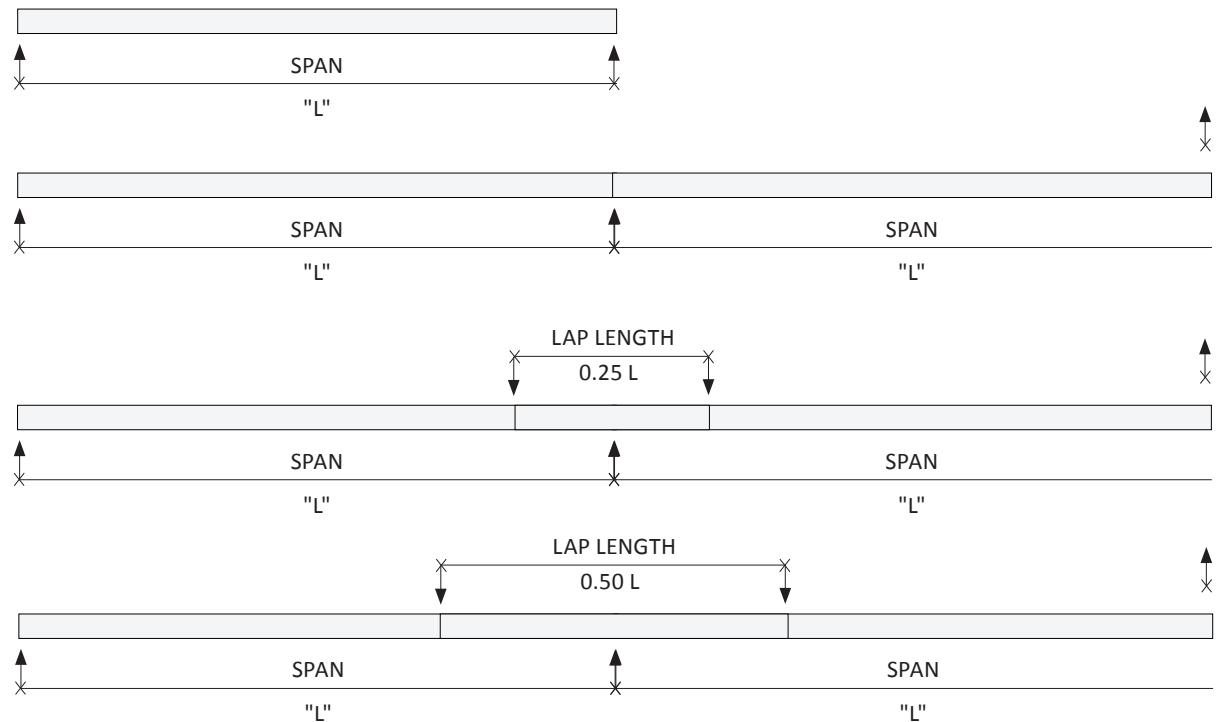
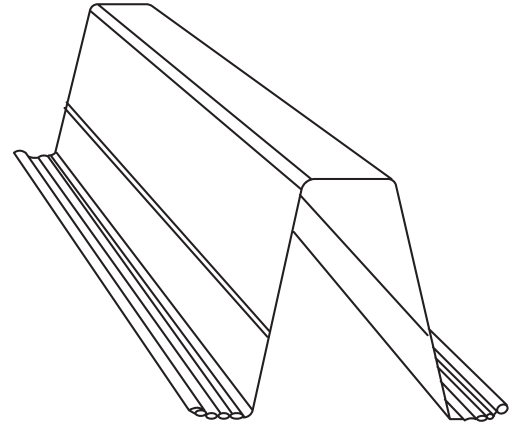

CEILING BATTENS

Spacing Tables 22mm

22MM X 0.42 BMT CEILING BATTEN

PLASTER THICKNESS	Spacing		
	450	600	900
1/10 mm	2140	1944	1698
1/13 mm	1974	1794	1567
1/16 mm	1851	1681	1469
2/10mm	1725	1567	1369
2/13 mm	1586	1441	1259
2/16 mm	1484	1348	1178

22MM X 0.75 BMT CEILING BATTEN

PLASTER THICKNESS	Spacing		
	450	600	900
1/10 mm	2595	2358	2060
1/13 mm	2395	2176	1901
1/16 mm	2245	2039	1782
2/10mm	2092	1901	1660
2/13 mm	1924	1748	1527
2/16 mm	1799	1635	1428

Where strength matters



Span Tables 40mm

40MM X 0.48 BMT G550 BATTEN SHEET ROOF

Wind Rating		MAX SPAN					WIND CLASS AS 4055
REGION	WIND TC AS1170.2	BATTEN SPACING					
		300	450	900	1200	1500	
D	TC3	1354	1373	1148	1047	970	N6/C4
	TC2	1354	1320	1087	986	909	N6/C4
C	TC3	1354	1486	1287	1192	1115	N5/C3
	TC2	1354	1442	1232	1133	1056	N5/C3
B	TC3	1354	1543	1401	1315	1243	N3/C1
	TC2	1354	1535	1353	1262	1188	N3/C1
A	TC3	1354	1543	1488	1412	1347	N1/N2
	TC2	1354	1543	1448	1367	1298	N1/N2

LL DEFLECTION CRITERIA Span/150

40MM X 0.55 BMT G300 BATTEN SHEET ROOF

Wind Rating		MAX SPAN					WIND CLASS AS 4055
REGION	WIND TC AS1170.2	BATTEN SPACING					
		300	450	900	1200	1500	
D	TC3	1199	1163	997	905	832	N6/C4
	TC2	1161	1112	934	843	772	N6/C4
C	TC3	1278	1276	1149	1061	985	N5/C3
	TC2	1248	1232	1087	996	921	N5/C3
B	TC3	1333	1362	1284	1206	1133	N3/C1
	TC2	1311	1326	1226	1142	1068	N3/C1
A	TC3	1372	1425	1395	1331	1265	N1/N2
	TC2	1354	1396	1343	1272	1202	N1/N2

LL DEFLECTION CRITERIA Span/150

40MM X 0.75 BMT G300 BATTEN SHEET ROOF

Wind Rating		MAX SPAN					WIND CLASS AS 4055
REGION	WIND TC AS1170.2	BATTEN SPACING					
		300	450	900	1200	1500	
D	TC3	1469	1409	1186	1071	981	N6/C4
	TC2	1418	1343	1109	996	909	N6/C4
C	TC3	1577	1558	1376	1262	1167	N5/C3
	TC2	1535	1499	1298	1182	1089	N5/C3
B	TC3	1654	1674	1547	1443	1349	N3/C1
	TC2	1622	1625	1473	1363	1268	N3/C1
A	TC3	1686	1759	1691	1601	1513	N1/N2
	TC2	1684	1720	1623	1526	1434	N1/N2

LL DEFLECTION CRITERIA Span/150

FIND OUT MORE ABOUT OUR RANGE
OF STEEL BUILDING PRODUCTS

MILLFORM AUSTRALIA



TOPHAT & BATTENS



PURLIN & CHANNEL



HOOKFAST PURLIN BRIDGING SYSTEM



ROOFING & WALLING



ROOFING ACCESSORIES



JUNCTION STUD & FACADE SYSTEM



SLAB & SPIRAL DUCT

MILLFORM OFFICE & MANUFACTURING FACILITY

Sydney

22 Shale Place, Eastern Creek, NSW, 2766
Ph. (02) 9832 6900

Albury

101 Ceres Drive, Albury, NSW, 2640
Ph. (02) 6025 4377

REGIONAL SALES TEAMS

QLD, NSW, ACT, VIC, TAS, WA, NT

**FOR SALES AND INFORMATION ENQUIRIES, CONTACT OUR
KNOWLEDGEABLE TEAM**

Call: **1300 645 376** or email: enquiries@millform.com.au

www.millform.com.au

Version 2.1

All reasonable care has been taken to present accurate information at the time of publication. All recommendations related to the use of Millform products are made without a guarantee. Many factors are beyond our control, and all information presented is meant as a guide only. It is the customer's responsibility to ensure that all products are suitable for their intended purpose. Millform reserves the right to change product specifications and recommendations at any time without prior notice. The Millform logo is registered and protected under Australian law.

