

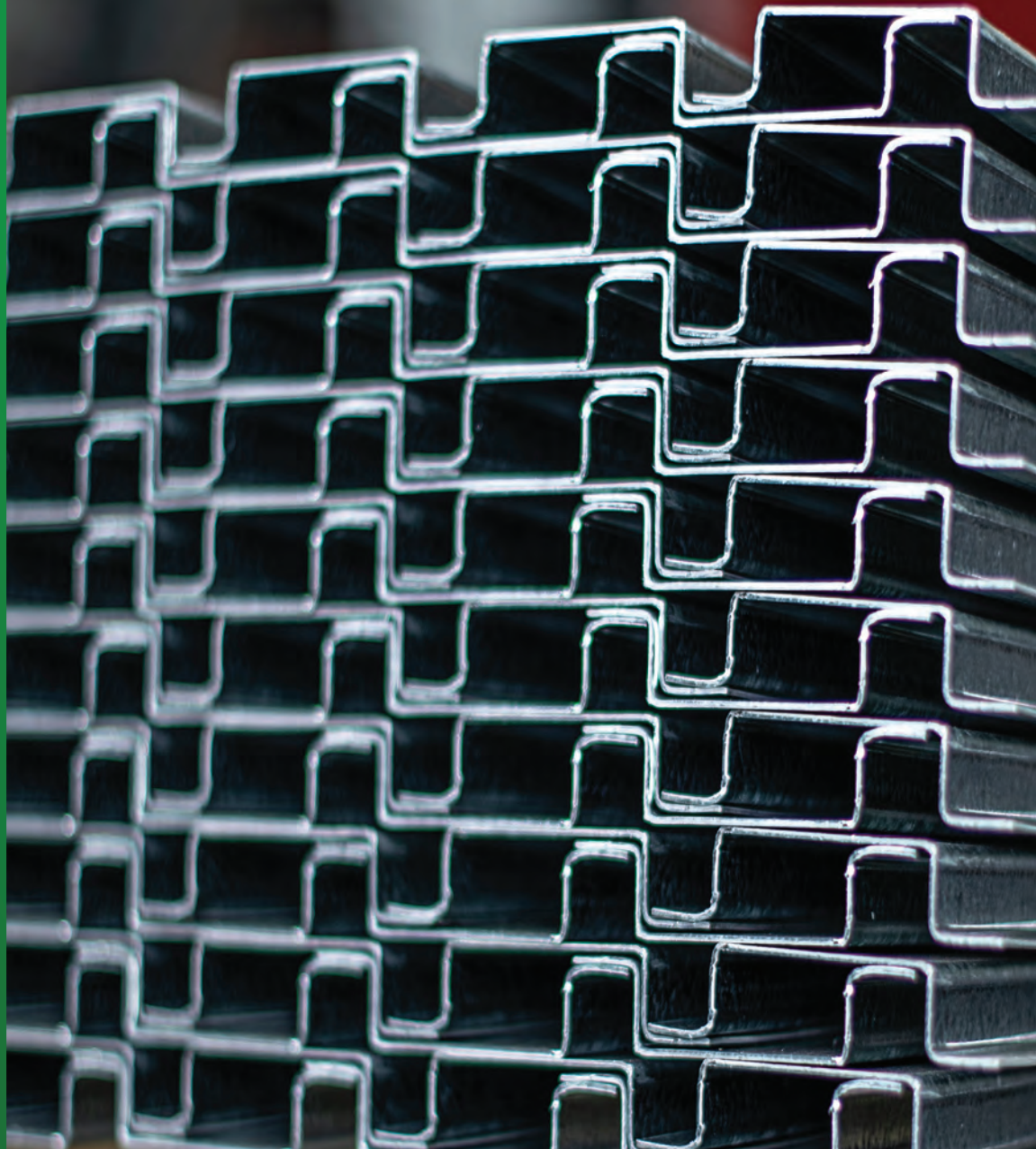

MILLFORM  
AUSTRALIA

Where strength matters



**Clad** *Form*<sup>™</sup> 

CLADDING SYSTEM

# MILLFORM JUNCTION STUD SPECIFICATIONS AND SPAN TABLES

## JUNCTION STUDS



Where strength matters



With the strength of steel, Millform is dedicated to building a better Australia. We provide quality products, ensure efficient delivery standards, and offer proven solutions for commercial, construction, industrial, and government clients.

You can find other Millform items on our website.

[www.millform.com.au](http://www.millform.com.au)

**Clad Form™**  
CLADDING SYSTEM

# CONTENTS

PAGE

**PRODUCT RANGE & PROPERTIES** 3

**SPAN TABLES** 6

- SPAN TABLES – JUNCTION STUD 0.55 / 0.75 7
- SPAN TABLES – JUNCTION STUD 1.10 14

## Junction Stud 0.75

### 50 x 15 Junction Stud

JUNCTION STUD - 50 X 15 X 0.75 BMT: **JS50150.75** (0.59kg/m)

**Standard Pack:** 50 Lengths x 6M

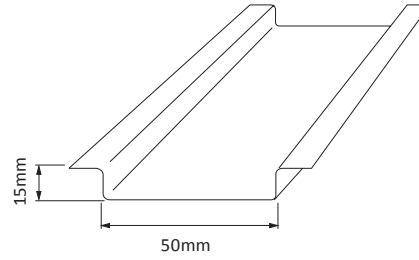

### 50 x 24 Junction Stud

JUNCTION STUD - 50 X 24 X 0.75 BMT: **JS50240.75** (0.80kg/m)

**Standard Pack:** 50 Lengths x 6M

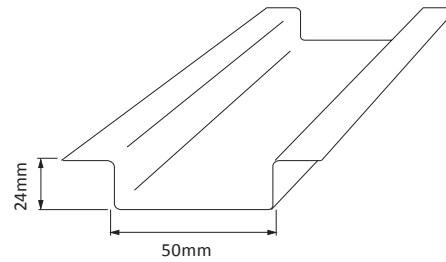

### 50 x 35 Junction Stud

JUNCTION STUD - 50 X 35 X 0.75 BMT: **JS50350.75** (0.91kg/m)

**Standard Pack:** 50 Lengths x 6M

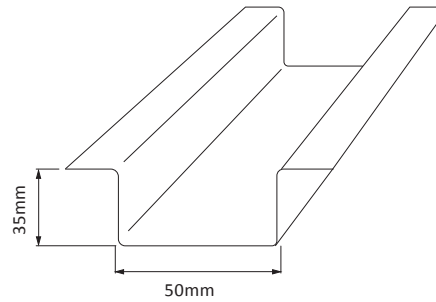

### 75 x 15 Junction Stud

JUNCTION STUD - 75 X 15 X 0.75 BMT: **JS75150.75** (0.80kg/m)

**Standard Pack:** 50 Lengths x 6M

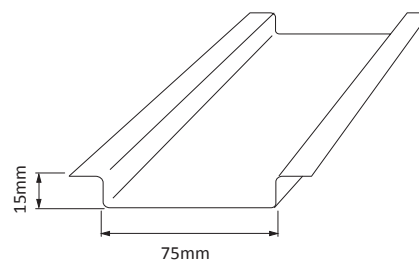

### 75 x 24 Junction Stud

JUNCTION STUD - 75 X 24 X 0.75 BMT: **JS75240.75** (0.91kg/m)

**Standard Pack:** 50 Lengths x 6M

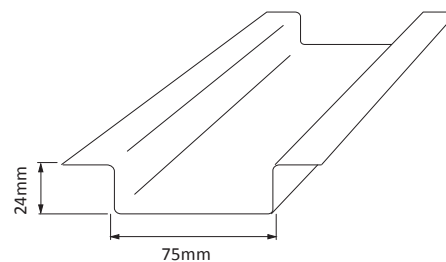

Where strength matters





# Junction Stud 0.75

<b>75 x 35 Junction Stud</b>
JUNCTION STUD - 75 X 35 X 0.75 BMT: <b>JS75350.75</b> (1.09kg/m)
<b>Standard Pack:</b> 50 Lengths x 6M

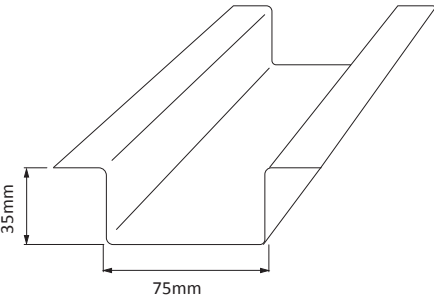

# Junction Stud 1.10

<b>50 x 15 Junction Stud</b>
JUNCTION STUD - 50 X 15 X 1.10 BMT: <b>JS5015</b> (0.89kg/m)
<b>Standard Pack:</b> 50 Lengths x 6M

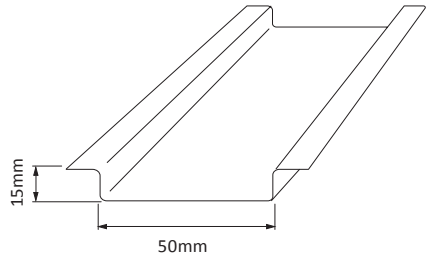

<b>50 x 24 Junction Stud</b>
JUNCTION STUD - 50 X 24 X 1.10 BMT: <b>JS5024</b> (1.13kg/m)
<b>Standard Pack:</b> 50 Lengths x 6M

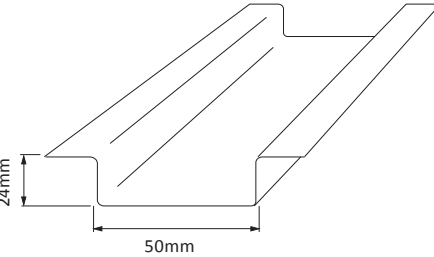

<b>50 x 35 Junction Stud</b>
JUNCTION STUD - 50 X 35 X 1.10 BMT: <b>JS5035</b> (1.33kg/m)
<b>Standard Pack:</b> 50 Lengths x 6M

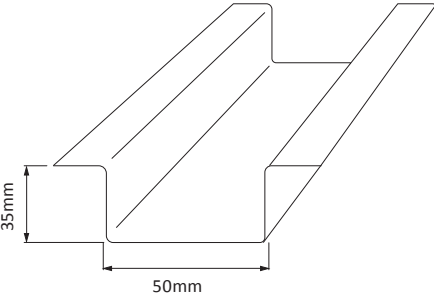

<b>50 x 50 Junction Stud</b>
JUNCTION STUD - 50 X 50 X 1.10 BMT: <b>JS5050</b> (1.56kg/m)
<b>Standard Pack:</b> 50 Lengths x 6M

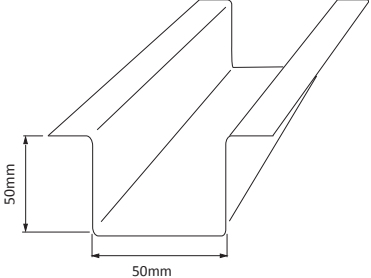

# Junction Stud 1.10

## 75 x 50 Junction Stud

JUNCTION STUD - 75 X 50 X 1.10 BMT: **JS7550** (1.91kg/m)

**Standard Pack:** 50 Lengths x 6M

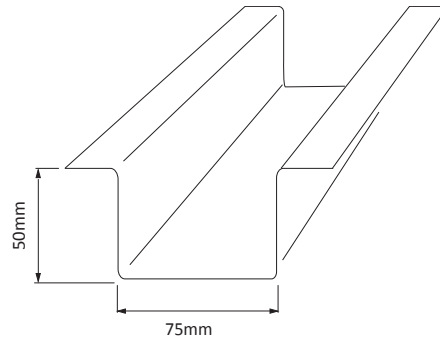

## 75 x 15 Junction Stud

JUNCTION STUD - 75 X 15 X 1.10 BMT: **JS7515** (1.13kg/m)

**Standard Pack:** 50 Lengths x 6M

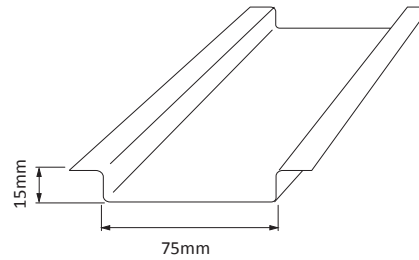

## 75 x 24 Junction Stud

JUNCTION STUD - 75 X 24 X 1.10 BMT: **JS7524** (1.33kg/m)

**Standard Pack:** 50 Lengths x 6M

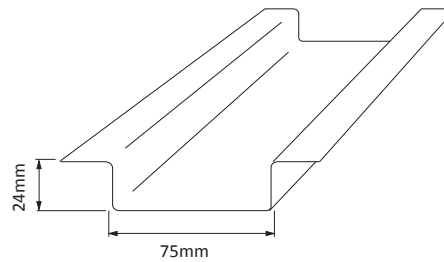

## 75 x 35 Junction Stud

JUNCTION STUD - 75 X 35 X 1.10 BMT: **JS7535** (1.56kg/m)

**Standard Pack:** 50 Lengths x 6M

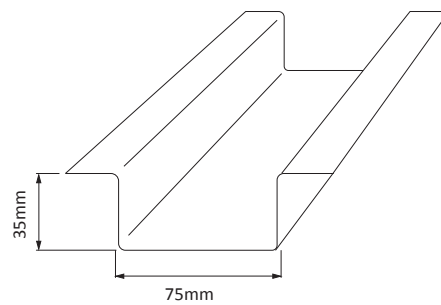

## 120 x 35 Junction Stud

JUNCTION STUD - 120 X 35 X 1.10 BMT: **JS12035** (1.97kg/m)

**Standard Pack:** 50 Lengths x 6M

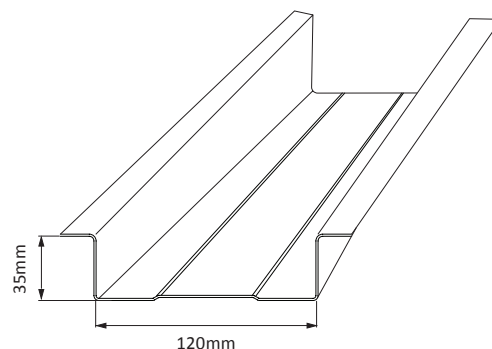

Where strength matters



## Design Codes, Standards & Guidelines

ASNZS 4600-2005 – Cold-formed Steel Structures

## Assumptions

1. When using the tables, loads are to be determined using the AS1170 series.
2. Continuous Span analysis assumed the long span being no more than 1.5 times as long as the short span. If spans exceed this, use Single Span Option.
3. Capacities are developed on the assumption that the junction studs are restrained at 300 mm centres by the supported claddings.
4. Design capacities consider inwards/outwards loadings. The lowest value displayed.

Where strength matters



# SPAN TABLES - JUNCTION STUD 0.55/0.75

## Member Schedule – Junction Studs

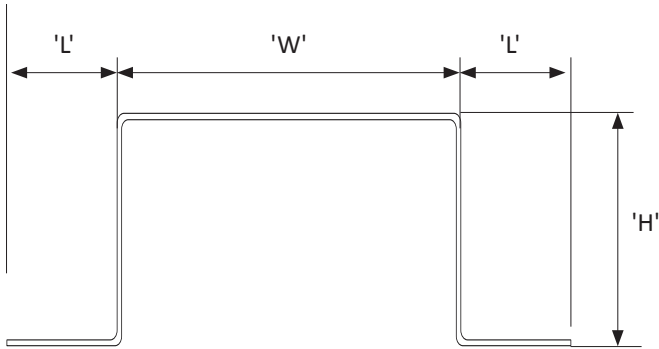

DESCRIPTION	Steel Grade (AS1397)	Nom Width "W"	Nom Height "H"	Leg Return "L"	BMT
		<b>W</b>	<b>H</b>	<b>L</b>	
JS50x35-0.55	G550	50	35	27	0.55
JS50x15-0.75	G550	50	15	12	0.75
JS50x24-0.75	G550	50	24	20	0.75
JS50x35-0.75	G550	50	35	18	0.75
JS50x50-0.75	G550	50	50	18	0.75
JS75x15-0.75	G550	75	15	16	0.75
JS75x24-0.75	G550	75	24	16	0.75
JS75x35-0.75	G550	75	35	20	0.75
JS75x50-0.75	G550	75	50	19	0.75
JS120x35-0.75	G550	120	35	20	0.75

Date of issue – December 2018 – Millform Products

Where strength matters





# Junction Stud – 0.55

## Design Capacities (kPa)

### JS50X35 – 0.55

Span	Spacing									
	450 c/c					600 c/c				
	Str	Span/250		Span/360		Str	Span/250		Span/360	
Single Span		Continuous Span	Single Span	Continuous Span	Single Span		Continuous Span	Single Span	Continuous Span	
500	6.95	12.72	24.46	8.83	16.98	5.21	9.54	18.34	6.62	12.74
750	3.09	3.77	7.25	2.62	5.03	2.32	2.83	5.44	1.96	3.77
1000	1.74	1.59	3.06	1.10	2.12	1.30	1.19	2.29	0.83	1.59
1250	1.11	0.81	1.57	0.57	1.09	0.83	0.61	1.17	0.42	0.82
1500	0.77	0.47	0.91	0.33	0.63	0.58	0.35	0.68	0.25	0.47
1750	0.57	0.30	0.57	0.21	0.40	0.43	0.22	0.43	0.15	0.30
2000	0.43	0.20	0.38	0.14	0.27	0.33	0.15	0.29	0.10	0.20
2250	0.34	0.14	0.27	0.10	0.19	0.26	0.10	0.20	0.07	0.14

**Notes:**

1. 'Str' denotes the Ultimate Design Capacity for the member. (Max carrying Load).
2. Continuous Span analysis assumed the long span being no more than 1.5 times as long as the short span. If spans exceed this, use Single Span Option.
3. Capacities are developed on the assumption that the junction studs are restrained at 300mm centres by the supported claddings.
4. All Capacities were designed in accordance with AS4600. Loads are to be determined using the AS1170 series.
5. Highlighted cell – Where the deflection load exceeds the 'Str'.
6. Design capacities consider inwards/outwards loadings. The lowest value displayed.



# Junction Stud – 0.75

## Design Capacities (kPa)

### JS50X15 – 0.75

Span	Spacing									
	450 c/c					600 c/c				
	Str	Span/250		Span/360		Str	Span/250		Span/360	
Single Span		Continuous Span	Single Span	Continuous Span	Single Span		Continuous Span	Single Span	Continuous Span	
500	2.53	2.62	5.04	1.82	3.50	1.90	1.96	3.78	1.36	2.62
750	1.12	0.78	1.49	0.54	1.04	0.84	0.58	1.12	0.40	0.78
1000	0.63	0.33	0.63	0.23	0.44	0.47	0.25	0.47	0.17	0.33
1250	0.40	0.17	0.32	0.12	0.22	0.30	0.13	0.24	0.09	0.17
1500	0.28	0.10	0.19	0.07	0.13	0.21	0.07	0.14	0.05	0.10
1750	0.21	0.06	0.12	0.04	0.08	0.15	0.05	0.09	0.03	0.06
2000	0.16	0.04	0.08	0.03	0.05	0.12	0.03	0.06	0.02	0.04
2250	0.12	0.03	0.06	0.02	0.04	0.09	0.02	0.04	0.01	0.03

### JS50X24 – 0.75

Span	Spacing									
	450 c/c					600 c/c				
	Str	Span/250		Span/360		Str	Span/250		Span/360	
Single Span		Continuous Span	Single Span	Continuous Span	Single Span		Continuous Span	Single Span	Continuous Span	
500	5.27	8.12	15.62	5.64	10.85	3.95	6.09	11.72	4.23	8.14
750	2.34	2.41	4.63	1.67	3.21	1.76	1.81	3.47	1.25	2.41
1000	1.32	1.02	1.95	0.71	1.36	0.99	0.76	1.46	0.53	1.02
1250	0.84	0.52	1.00	0.36	0.69	0.63	0.39	0.75	0.27	0.52
1500	0.59	0.30	0.58	0.21	0.40	0.44	0.23	0.43	0.16	0.30
1750	0.43	0.19	0.36	0.13	0.25	0.32	0.14	0.27	0.10	0.19
2000	0.33	0.13	0.24	0.09	0.17	0.25	0.10	0.18	0.07	0.13
2250	0.26	0.09	0.17	0.06	0.12	0.20	0.07	0.13	0.05	0.09

#### Notes:

1. 'Str' denotes the Ultimate Design Capacity for the member. (Max carrying Load).
2. Continuous Span analysis assumed the long span being no more than 1.5 times as long as the short span. If spans exceed this, use Single Span Option.
3. Capacities are developed on the assumption that the junction studs are restrained at 300mm centres by the supported claddings.
4. All Capacities were designed in accordance with AS4600. Loads are to be determined using the AS1170 series.
5. Highlighted cell – Where the deflection load exceeds the 'Str'.
6. Design capacities consider inwards/outwards loadings. The lowest value displayed.

Where strength matters





# Junction Stud – 0.75

## Design Capacities (kPa)

### JS50X35 – 0.75

Span	Spacing									
	450 c/c					600 c/c				
	Str	Span/250		Span/360		Str	Span/250		Span/360	
Single Span		Continuous Span	Single Span	Continuous Span	Single Span		Continuous Span	Single Span	Continuous Span	
500	11.03	19.12	36.76	13.28	25.53	8.27	14.34	27.57	9.96	19.15
750	4.90	5.66	10.89	3.93	7.56	3.68	4.25	8.17	2.95	5.67
1000	2.76	2.39	4.60	1.66	3.19	2.07	1.79	3.45	1.24	2.39
1250	1.76	1.22	2.35	0.85	1.63	1.32	0.92	1.76	0.64	1.23
1500	1.23	0.71	1.36	0.49	0.95	0.92	0.53	1.02	0.37	0.71
1750	0.90	0.45	0.86	0.31	0.60	0.68	0.33	0.64	0.23	0.45
2000	0.69	0.30	0.57	0.21	0.40	0.52	0.22	0.43	0.16	0.30
2250	0.54	0.21	0.40	0.15	0.28	0.41	0.16	0.30	0.11	0.21

### JS50X50 – 0.75

Span	Spacing									
	450 c/c					600 c/c				
	Str	Span/250		Span/360		Str	Span/250		Span/360	
Single Span		Continuous Span	Single Span	Continuous Span	Single Span		Continuous Span	Single Span	Continuous Span	
500	19.89	41.09	79.03	28.54	54.88	14.92	30.82	59.27	21.40	41.16
750	8.84	12.18	23.42	8.46	16.26	6.63	9.13	17.56	6.34	12.20
1000	4.97	5.14	9.88	3.57	6.86	3.73	3.85	7.41	2.68	5.15
1250	3.18	2.63	5.06	1.83	3.51	2.39	1.97	3.79	1.37	2.63
1500	2.21	1.52	2.93	1.06	2.03	1.66	1.14	2.20	0.79	1.52
1750	1.62	0.96	1.84	0.67	1.28	1.22	0.72	1.38	0.50	0.96
2000	1.24	0.64	1.23	0.45	0.86	0.93	0.48	0.93	0.33	0.64
2250	0.98	0.45	0.87	0.31	0.60	0.74	0.34	0.65	0.23	0.45

**Notes:**

1. 'Str' denotes the Ultimate Design Capacity for the member. (Max carrying Load).
2. Continuous Span analysis assumed the long span being no more than 1.5 times as long as the short span. If spans exceed this, use Single Span Option.
3. Capacities are developed on the assumption that the junction studs are restrained at 300mm centres by the supported claddings.
4. All Capacities were designed in accordance with AS4600. Loads are to be determined using the AS1170 series.
5. Highlighted cell – Where the deflection load exceeds the 'Str'.
6. Design capacities consider inwards/outwards loadings. The lowest value displayed.

# Junction Stud – 0.75

## Design Capacities (kPa)

### JS75X15 – 0.75

Span	Spacing									
	450 c/c					600 c/c				
	Str	Span/250		Span/360		Str	Span/250		Span/360	
Single Span		Continuous Span	Single Span	Continuous Span	Single Span		Continuous Span	Single Span	Continuous Span	
500	3.68	3.05	5.86	2.12	4.07	2.76	2.28	4.39	1.59	3.05
750	1.63	0.90	1.74	0.63	1.21	1.23	0.68	1.30	0.47	0.90
1000	0.92	0.38	0.73	0.26	0.51	0.69	0.29	0.55	0.20	0.38
1250	0.59	0.19	0.37	0.14	0.26	0.44	0.15	0.28	0.10	0.20
1500	0.41	0.11	0.22	0.08	0.15	0.31	0.08	0.16	0.06	0.11
1750	0.30	0.07	0.14	0.05	0.09	0.23	0.05	0.10	0.04	0.07
2000	0.23	0.05	0.09	0.03	0.06	0.17	0.04	0.07	0.02	0.05
2250	0.18	0.03	0.06	0.02	0.04	0.14	0.03	0.05	0.02	0.03

### JS75X24 – 0.75

Span	Spacing									
	450 c/c					600 c/c				
	Str	Span/250		Span/360		Str	Span/250		Span/360	
Single Span		Continuous Span	Single Span	Continuous Span	Single Span		Continuous Span	Single Span	Continuous Span	
500	10.89	9.18	17.66	6.38	12.27	8.17	6.89	13.25	4.78	9.20
750	4.84	2.72	5.23	1.89	3.63	3.63	2.04	3.93	1.42	2.73
1000	2.72	1.15	2.21	0.80	1.53	2.04	0.86	1.66	0.60	1.15
1250	1.74	0.59	1.13	0.41	0.79	1.31	0.44	0.85	0.31	0.59
1500	1.21	0.34	0.65	0.24	0.45	0.91	0.26	0.49	0.18	0.34
1750	0.89	0.21	0.41	0.15	0.29	0.67	0.16	0.31	0.11	0.21
2000	0.68	0.14	0.28	0.10	0.19	0.51	0.11	0.21	0.07	0.14
2250	0.54	0.10	0.19	0.07	0.13	0.40	0.08	0.15	0.05	0.10

#### Notes:

- 'Str' denotes the Ultimate Design Capacity for the member. (Max carrying Load).
- Continuous Span analysis assumed the long span being no more than 1.5 times as long as the short span. If spans exceed this, use Single Span Option.
- Capacities are developed on the assumption that the junction studs are restrained at 300mm centres by the supported claddings.
- All Capacities were designed in accordance with AS4600. Loads are to be determined using the AS1170 series.
- Highlighted cell – Where the deflection load exceeds the 'Str'.
- Design capacities consider inwards/outwards loadings. The lowest value displayed.

Where strength matters





# Junction Stud – 0.75

## Design Capacities (kPa)

### JS75X35 - 0.75

Span	Spacing									
	450 c/c					600 c/c				
	Str	Span/250		Span/360		Str	Span/250		Span/360	
Single Span		Continuous Span	Single Span	Continuous Span	Single Span		Continuous Span	Single Span	Continuous Span	
500	20.23	21.56	41.47	14.97	28.80	15.17	16.17	31.10	11.23	21.60
750	8.99	6.39	12.29	4.44	8.53	6.74	4.79	9.21	3.33	6.40
1000	5.06	2.70	5.18	1.87	3.60	3.79	2.02	3.89	1.40	2.70
1250	3.24	1.38	2.65	0.96	1.84	2.43	1.03	1.99	0.72	1.38
1500	2.25	0.80	1.54	0.55	1.07	1.69	0.60	1.15	0.42	0.80
1750	1.65	0.50	0.97	0.35	0.67	1.24	0.38	0.73	0.26	0.50
2000	1.26	0.34	0.65	0.23	0.45	0.95	0.25	0.49	0.18	0.34
2250	1.00	0.24	0.46	0.16	0.32	0.75	0.18	0.34	0.12	0.24

### JS75X50 - 0.75

Span	Spacing									
	450 c/c					600 c/c				
	Str	Span/250		Span/360		Str	Span/250		Span/360	
Single Span		Continuous Span	Single Span	Continuous Span	Single Span		Continuous Span	Single Span	Continuous Span	
500	32.40	45.73	87.95	31.76	61.08	24.30	34.30	65.96	23.82	45.81
750	14.40	13.55	26.06	9.41	18.10	10.80	10.16	19.54	7.06	13.57
1000	8.10	5.72	10.99	3.97	7.63	6.07	4.29	8.25	2.98	5.73
1250	5.18	2.93	5.63	2.03	3.91	3.89	2.20	4.22	1.52	2.93
1500	3.60	1.69	3.26	1.18	2.26	2.70	1.27	2.44	0.88	1.70
1750	2.64	1.07	2.05	0.74	1.42	1.98	0.80	1.54	0.56	1.07
2000	2.02	0.71	1.37	0.50	0.95	1.52	0.54	1.03	0.37	0.72
2250	1.60	0.50	0.97	0.35	0.67	1.20	0.38	0.72	0.26	0.50
2500	1.29	0.37	0.70	0.25	0.49	0.97	0.27	0.53	0.19	0.37
2750	1.07	0.27	0.53	0.19	0.37	0.80	0.21	0.40	0.14	0.28

**Notes:**

1. 'Str' denotes the Ultimate Design Capacity for the member. (Max carrying Load).
2. Continuous Span analysis assumed the long span being no more than 1.5 times as long as the short span. If spans exceed this, use Single Span Option.
3. Capacities are developed on the assumption that the junction studs are restrained at 300mm centres by the supported claddings.
4. All Capacities were designed in accordance with AS4600. Loads are to be determined using the AS1170 series.
5. Highlighted cell – Where the deflection load exceeds the 'Str'.
6. Design capacities consider inwards/outwards loadings. The lowest value displayed.

# Junction Stud – 0.75

## Design Capacities (kPa)

### JS120X35 - 0.75

Span	Spacing									
	450 c/c					600 c/c				
	Str	Span/250		Span/360		Str	Span/250		Span/360	
Single Span		Continuous Span	Single Span	Continuous Span	Single Span		Continuous Span	Single Span	Continuous Span	
500	25.20	23.87	45.91	16.58	31.88	18.90	17.90	34.43	12.43	23.91
750	11.20	7.07	13.60	4.91	9.45	8.40	5.30	10.20	3.68	7.08
1000	6.30	2.98	5.74	2.07	3.98	4.73	2.24	4.30	1.55	2.99
1250	4.03	1.53	2.94	1.06	2.04	3.02	1.15	2.20	0.80	1.53
1500	2.80	0.88	1.70	0.61	1.18	2.10	0.66	1.28	0.46	0.89
1750	2.06	0.56	1.07	0.39	0.74	1.54	0.42	0.80	0.29	0.56
2000	1.58	0.37	0.72	0.26	0.50	1.18	0.28	0.54	0.19	0.37
2250	1.24	0.26	0.50	0.18	0.35	0.93	0.20	0.38	0.14	0.26

#### Notes:

1. 'Str' denotes the Ultimate Design Capacity for the member. (Max carrying Load).
2. Continuous Span analysis assumed the long span being no more than 1.5 times as long as the short span. If spans exceed this, use Single Span Option.
3. Capacities are developed on the assumption that the junction studs are restrained at 300mm centres by the supported claddings.
4. All Capacities were designed in accordance with AS4600. Loads are to be determined using the AS1170 series.
5. Highlighted cell – Where the deflection load exceeds the 'Str'.
6. Design capacities consider inwards/outwards loadings. The lowest value displayed.

Where strength matters



## Member Schedule – Junction Studs

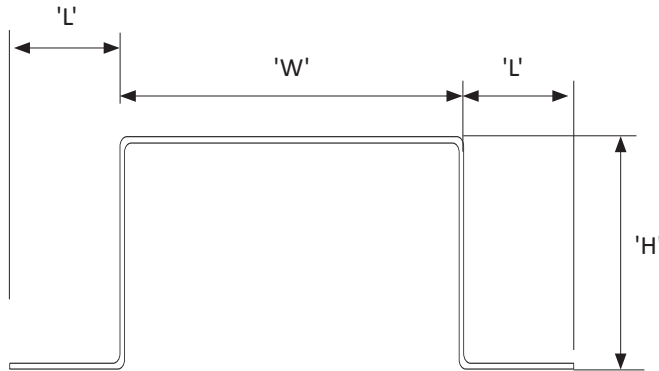

DESCRIPTION	Steel Grade (AS1397)	Nom Width "W"	Nom Height "H"	Leg Return "L"	BMT
		W	H	L	
JS50x15-1.10	G250	50	15	14	1.10
JS50x24-1.10	G250	50	24	18	1.10
JS50x35-1.10	G250	50	35	19	1.10
JS50x50-1.10	G250	50	50	17	1.10
JS75x15-1.10	G250	75	15	15	1.10
JS75x24-1.10	G250	75	24	17	1.10
JS75x35-1.10	G250	75	35	20	1.10
JS75x50-1.10	G250	75	50	20	1.10
JS120x35-1.10	G250	120	35	20	1.10

Date of issue – December 2018 – Millform Products



# Junction Stud – 1.10

## Design Capacities (kPa)

### JS50X15 - 1.10

Span	Spacing									
	450 c/c					600 c/c				
	Str	Span/250		Span/360		Str	Span/250		Span/360	
Single Span		Continuous Span	Single Span	Continuous Span	Single Span		Continuous Span	Single Span	Continuous Span	
500	3.83	4.60	8.84	3.19	6.14	2.87	3.45	6.63	2.40	4.61
750	1.70	1.36	2.62	0.95	1.82	1.28	1.02	1.97	0.71	1.36
1000	0.96	0.57	1.11	0.40	0.77	0.72	0.43	0.83	0.30	0.58
1250	0.61	0.29	0.57	0.20	0.39	0.46	0.22	0.42	0.15	0.29
1500	0.43	0.17	0.33	0.12	0.23	0.32	0.13	0.25	0.09	0.17
1750	0.31	0.11	0.21	0.07	0.14	0.23	0.08	0.15	0.06	0.11
2000	0.24	0.07	0.14	0.05	0.10	0.18	0.05	0.10	0.04	0.07
2250	0.19	0.05	0.10	0.04	0.07	0.14	0.04	0.07	0.03	0.05

### JS50X24 - 1.10

Span	Spacing									
	450 c/c					600 c/c				
	Str	Span/250		Span/360		Str	Span/250		Span/360	
Single Span		Continuous Span	Single Span	Continuous Span	Single Span		Continuous Span	Single Span	Continuous Span	
500	9.36	14.43	27.75	10.02	19.27	7.02	10.82	20.81	7.52	14.45
750	4.16	4.28	8.22	2.97	5.71	3.12	3.21	6.17	2.23	4.28
1000	2.34	1.80	3.47	1.25	2.41	1.75	1.35	2.60	0.94	1.81
1250	1.50	0.92	1.78	0.64	1.23	1.12	0.69	1.33	0.48	0.92
1500	1.04	0.53	1.03	0.37	0.71	0.78	0.40	0.77	0.28	0.54
1750	0.76	0.34	0.65	0.23	0.45	0.57	0.25	0.49	0.18	0.34
2000	0.58	0.23	0.43	0.16	0.30	0.44	0.17	0.33	0.12	0.23
2250	0.46	0.16	0.30	0.11	0.21	0.35	0.12	0.23	0.08	0.16

#### Notes:

- 'Str' denotes the Ultimate Design Capacity for the member. (Max carrying Load).
- Continuous Span analysis assumed the long span being no more than 1.5 times as long as the short span. If spans exceed this, use Single Span Option.
- Capacities are developed on the assumption that the junction studs are restrained at 300mm centres by the supported claddings.
- All Capacities were designed in accordance with AS4600. Loads are to be determined using the AS1170 series.
- Highlighted cell – Where the deflection load exceeds the 'Str'.
- Design capacities consider inwards/outwards loadings. The lowest value displayed.

Where strength matters





# Junction Stud – 1.10

## Design Capacities (kPa)

### JS50X35 – 1.10

Span	Spacing									
	450 c/c					600 c/c				
	Str	Span/250		Span/360		Str	Span/250		Span/360	
Single Span		Continuous Span	Single Span	Continuous Span	Single Span		Continuous Span	Single Span	Continuous Span	
500	18.08	34.40	66.15	23.89	45.94	13.56	25.80	49.61	17.91	34.45
750	8.04	10.19	19.60	7.08	13.61	6.03	7.64	14.70	5.31	10.21
1000	4.52	4.30	8.27	2.99	5.74	3.39	3.22	6.20	2.24	4.31
1250	2.89	2.20	4.23	1.53	2.94	2.17	1.65	3.18	1.15	2.20
1500	2.01	1.27	2.45	0.88	1.70	1.51	0.96	1.84	0.66	1.28
1750	1.48	0.80	1.54	0.56	1.07	1.11	0.60	1.16	0.42	0.80
2000	1.13	0.54	1.03	0.37	0.72	0.85	0.40	0.78	0.28	0.54
2250	0.89	0.38	0.73	0.26	0.50	0.67	0.28	0.54	0.20	0.38

### JS50X50 – 1.10

Span	Spacing									
	450 c/c					600 c/c				
	Str	Span/250		Span/360		Str	Span/250		Span/360	
Single Span		Continuous Span	Single Span	Continuous Span	Single Span		Continuous Span	Single Span	Continuous Span	
500	31.34	78.22	150.42	54.32	104.46	23.50	58.67	112.82	40.74	78.35
750	13.93	23.18	44.57	16.09	30.95	10.45	17.38	33.43	12.07	23.21
1000	7.83	9.78	18.80	6.79	13.06	5.88	7.33	14.10	5.09	9.79
1250	5.01	5.01	9.63	3.48	6.69	3.76	3.75	7.22	2.61	5.01
1500	3.48	2.90	5.57	2.01	3.87	2.61	2.17	4.18	1.51	2.90
1750	2.56	1.82	3.51	1.27	2.44	1.92	1.37	2.63	0.95	1.83
2000	1.96	1.22	2.35	0.85	1.63	1.47	0.92	1.76	0.64	1.22
2250	1.55	0.86	1.65	0.60	1.15	1.16	0.64	1.24	0.45	0.86
2500	1.25	0.63	1.20	0.43	0.84	0.94	0.47	0.90	0.33	0.63
2750	1.03	0.47	0.90	0.33	0.63	0.77	0.35	0.68	0.24	0.47
3000	0.86	0.36	0.70	0.25	0.48	0.65	0.27	0.52	0.19	0.36

**Notes:**

1. 'Str' denotes the Ultimate Design Capacity for the member. (Max carrying Load).
2. Continuous Span analysis assumed the long span being no more than 1.5 times as long as the short span. If spans exceed this, use Single Span Option.
3. Capacities are developed on the assumption that the junction studs are restrained at 300mm centres by the supported claddings.
4. All Capacities were designed in accordance with AS4600. Loads are to be determined using the AS1170 series.
5. Highlighted cell – Where the deflection load exceeds the 'Str'.
6. Design capacities consider inwards/outwards loadings. The lowest value displayed.



# Junction Stud – 1.10

## Design Capacities (kPa)

### JS75X15 – 1.10

Span	Spacing									
	450 c/c					600 c/c				
	Str	Span/250		Span/360		Str	Span/250		Span/360	
Single Span		Continuous Span	Single Span	Continuous Span	Single Span		Continuous Span	Single Span	Continuous Span	
500	6.01	5.25	10.10	3.65	7.01	4.51	3.94	7.57	2.73	5.26
750	2.67	1.56	2.99	1.08	2.08	2.00	1.17	2.24	0.81	1.56
1000	1.50	0.66	1.26	0.46	0.88	1.13	0.49	0.95	0.34	0.66
1250	0.96	0.34	0.65	0.23	0.45	0.72	0.25	0.48	0.17	0.34
1500	0.67	0.19	0.37	0.14	0.26	0.50	0.15	0.28	0.10	0.19
1750	0.49	0.12	0.24	0.09	0.16	0.37	0.09	0.18	0.06	0.12
2000	0.38	0.08	0.16	0.06	0.11	0.28	0.06	0.12	0.04	0.08
2250	0.30	0.06	0.11	0.04	0.08	0.22	0.04	0.08	0.03	0.06

### JS75X24 – 1.10

Span	Spacing									
	450 c/c					600 c/c				
	Str	Span/250		Span/360		Str	Span/250		Span/360	
Single Span		Continuous Span	Single Span	Continuous Span	Single Span		Continuous Span	Single Span	Continuous Span	
500	13.96	16.59	31.91	11.52	22.16	10.47	12.44	23.93	8.64	16.62
750	6.20	4.92	9.45	3.41	6.57	4.65	3.69	7.09	2.56	4.92
1000	3.49	2.07	3.99	1.44	2.77	2.62	1.56	2.99	1.08	2.08
1250	2.23	1.06	2.04	0.74	1.42	1.67	0.80	1.53	0.55	1.06
1500	1.55	0.61	1.18	0.43	0.82	1.16	0.46	0.89	0.32	0.62
1750	1.14	0.39	0.74	0.27	0.52	0.85	0.29	0.56	0.20	0.39
2000	0.87	0.26	0.50	0.18	0.35	0.65	0.19	0.37	0.14	0.26
2250	0.69	0.18	0.35	0.13	0.24	0.52	0.14	0.26	0.09	0.18

#### Notes:

- 'Str' denotes the Ultimate Design Capacity for the member. (Max carrying Load).
- Continuous Span analysis assumed the long span being no more than 1.5 times as long as the short span. If spans exceed this, use Single Span Option.
- Capacities are developed on the assumption that the junction studs are restrained at 300mm centres by the supported claddings.
- All Capacities were designed in accordance with AS4600. Loads are to be determined using the AS1170 series.
- Highlighted cell – Where the deflection load exceeds the 'Str'.
- Design capacities consider inwards/outwards loadings. The lowest value displayed.

Where strength matters





# Junction Stud – 1.10

## Design Capacities (kPa)

### JS75X35 - 1.10

Span	Spacing									
	450 c/c					600 c/c				
	Str	Span/250		Span/360		Str	Span/250		Span/360	
Single Span		Continuous Span	Single Span	Continuous Span	Single Span		Continuous Span	Single Span	Continuous Span	
500	25.07	40.31	77.53	28.00	53.84	18.80	30.24	58.15	21.00	40.38
750	11.14	11.95	22.97	8.30	15.95	8.36	8.96	17.23	6.22	11.96
1000	6.27	5.04	9.69	3.50	6.73	4.70	3.78	7.27	2.62	5.05
1250	4.01	2.58	4.96	1.79	3.45	3.01	1.94	3.72	1.34	2.58
1500	2.79	1.49	2.87	1.04	1.99	2.09	1.12	2.15	0.78	1.50
1750	2.05	0.94	1.81	0.65	1.26	1.54	0.71	1.36	0.49	0.94
2000	1.57	0.63	1.21	0.44	0.84	1.18	0.47	0.91	0.33	0.63
2250	1.24	0.44	0.85	0.31	0.59	0.93	0.33	0.64	0.23	0.44

### JS75X50 - 1.10

Span	Spacing									
	450 c/c					600 c/c				
	Str	Span/250		Span/360		Str	Span/250		Span/360	
Single Span		Continuous Span	Single Span	Continuous Span	Single Span		Continuous Span	Single Span	Continuous Span	
500	42.47	92.18	177.26	64.01	123.10	31.86	69.13	132.95	48.01	92.33
750	18.88	27.31	52.52	18.97	36.47	14.16	20.48	39.39	14.22	27.36
1000	10.62	11.52	22.16	8.00	15.39	7.96	8.64	16.62	6.00	11.54
1250	6.80	5.90	11.34	4.10	7.88	5.10	4.42	8.51	3.07	5.91
1500	4.72	3.41	6.57	2.37	4.56	3.54	2.56	4.92	1.78	3.42
1750	3.47	2.15	4.13	1.49	2.87	2.60	1.61	3.10	1.12	2.15
2000	2.65	1.44	2.77	1.00	1.92	1.99	1.08	2.08	0.75	1.44
2250	2.10	1.01	1.95	0.70	1.35	1.57	0.76	1.46	0.53	1.01
2500	1.70	0.74	1.42	0.51	0.98	1.27	0.55	1.06	0.38	0.74
2750	1.40	0.55	1.07	0.38	0.74	1.05	0.42	0.80	0.29	0.55
3000	1.18	0.43	0.82	0.30	0.57	0.88	0.32	0.62	0.22	0.43
3250	1.00	0.34	0.65	0.23	0.45	0.75	0.25	0.48	0.17	0.34
3500	0.86	0.27	0.52	0.19	0.36	0.65	0.20	0.39	0.14	0.27

**Notes:**

1. 'Str' denotes the Ultimate Design Capacity for the member. (Max carrying Load).
2. Continuous Span analysis assumed the long span being no more than 1.5 times as long as the short span. If spans exceed this, use Single Span Option.
3. Capacities are developed on the assumption that the junction studs are restrained at 300mm centres by the supported claddings.
4. All Capacities were designed in accordance with AS4600. Loads are to be determined using the AS1170 series.
5. Highlighted cell – Where the deflection load exceeds the 'Str'.
6. Design capacities consider inwards/outwards loadings. The lowest value displayed.

# Junction Stud – 1.10

## Design Capacities (kPa)

### JS120X35 – 1.10

Span	Spacing									
	450 c/c					600 c/c				
	Str	Span/250		Span/360		Str	Span/250		Span/360	
		Single Span	Continuous Span	Single Span	Continuous Span		Single Span	Continuous Span	Single Span	Continuous Span
500	28.56	43.93	84.49	30.51	58.67	21.42	32.95	63.37	22.88	44.00
750	12.69	13.02	25.03	9.04	17.38	9.52	9.76	18.77	6.78	13.04
1000	7.14	5.49	10.56	3.81	7.33	5.35	4.12	7.92	2.86	5.50
1250	4.57	2.81	5.41	1.95	3.75	3.43	2.11	4.06	1.46	2.82
1500	3.17	1.63	3.13	1.13	2.17	2.38	1.22	2.35	0.85	1.63
1750	2.33	1.02	1.97	0.71	1.37	1.75	0.77	1.48	0.53	1.03
2000	1.78	0.69	1.32	0.48	0.92	1.34	0.51	0.99	0.36	0.69
2250	1.41	0.48	0.93	0.33	0.64	1.06	0.36	0.70	0.25	0.48
4000	0.45	0.09	0.17	0.06	0.11	0.33	0.06	0.12	0.04	0.09

#### Notes:

1. 'Str' denotes the Ultimate Design Capacity for the member. (Max carrying Load).
2. Continuous Span analysis assumed the long span being no more than 1.5 times as long as the short span. If spans exceed this, use Single Span Option.
3. Capacities are developed on the assumption that the junction studs are restrained at 300mm centres by the supported claddings.
4. All Capacities were designed in accordance with AS4600. Loads are to be determined using the AS1170 series.
5. Highlighted cell – Where the deflection load exceeds the 'Str'.
6. Design capacities consider inwards/outwards loadings. The lowest value displayed.

Where strength matters



FIND OUT MORE ABOUT OUR RANGE  
OF STEEL BUILDING PRODUCTS

**M** **MILLFORM**  
**AUSTRALIA**



**TOPHAT & BATTENS**



**PURLIN & CHANNEL**



**HOOKFAST PURLIN BRIDGING SYSTEM**



**ROOFING & WALLING**



**ROOFING ACCESSORIES**



**JUNCTION STUD & FACADE SYSTEM**



**SLAB & SPIRAL DUCT**

## MILLFORM OFFICE & MANUFACTURING FACILITY

### Sydney

22 Shale Place, Eastern Creek, NSW, 2766  
Ph. (02) 9832 6900

### Albury

101 Ceres Drive, Albury, NSW, 2640  
Ph. (02) 6025 4377

## REGIONAL SALES TEAMS

**QLD, NSW, ACT, VIC, TAS, WA, NT**

**FOR SALES AND INFORMATION ENQUIRIES, CONTACT OUR  
KNOWLEDGEABLE TEAM**

Call: **1300 645 376** or email: [sales@millform.com.au](mailto:sales@millform.com.au)

[www.millform.com.au](http://www.millform.com.au)

All reasonable care has been taken to present accurate information at the time of publication. All recommendations related to the use of Millform products are made without a guarantee. Many factors are beyond our control, and all information presented is meant as a guide only. It is the customer's responsibility to ensure that all products are suitable for their intended purpose. Millform reserves the right to change product specifications and recommendations at any time without prior notice. The Millform logo is registered and protected under Australian law.

